

VECO VANSONIC ENTERPRISE CO., LTD.

8F., No. 7, Lane 16, Sec. 2, Szechwan Road, Panchiao, Taipei Hsien, TAIWAN.

TEL: +886-2-29626335

FAX: +886-2-29625220

E-MAIL: vansonice@ms4.hinet.net

1.	MODEL:	35KP08			
2.	Dimension	Outer Diameter	16X35 mm.	Baffle Opening	15X32 mm.
		Height	Refer to Drawing .	Weight	4.2 Grams.
3.	Magnet	Materials	Rare Earth .	Size	∅ 8.0X2 mm.
4.	Nominal Impedance	8	± 15 %	At	1200 Hz.
5.	Power Rating	Normal	1000 mW.	Maximum	2000 mW.
6.	Lowest Resonant Frequency	550	± 20 %		Hz.
7.	Output Sound Pressure Level (S.P.L.)	84	± 3 db / 1.0 Watt .	0.5 Meter.	
		Average at	600, 800, 1000, 1200	Hz.	
8.	Frequency Range	380	~ 13000 Hz.	Average SPL - 10 db.	
9.	Distortion	5 %	Maximum At	1000 Hz.	1000 mW.
10.	Abnormal Sound Test	Must Be Normal Test By 2.9 Volts. Sine Wave.			
11.	Load Test	White Noise With Weighted Filter 2.9 Volts.(RMS) 24 Hrs.			
12.	Polarity	Diaphragm shall move Forward when Apply a Positive DC.			
		Current to the "+" or "Marked" Terminal.			

MOUNTING NOTICE

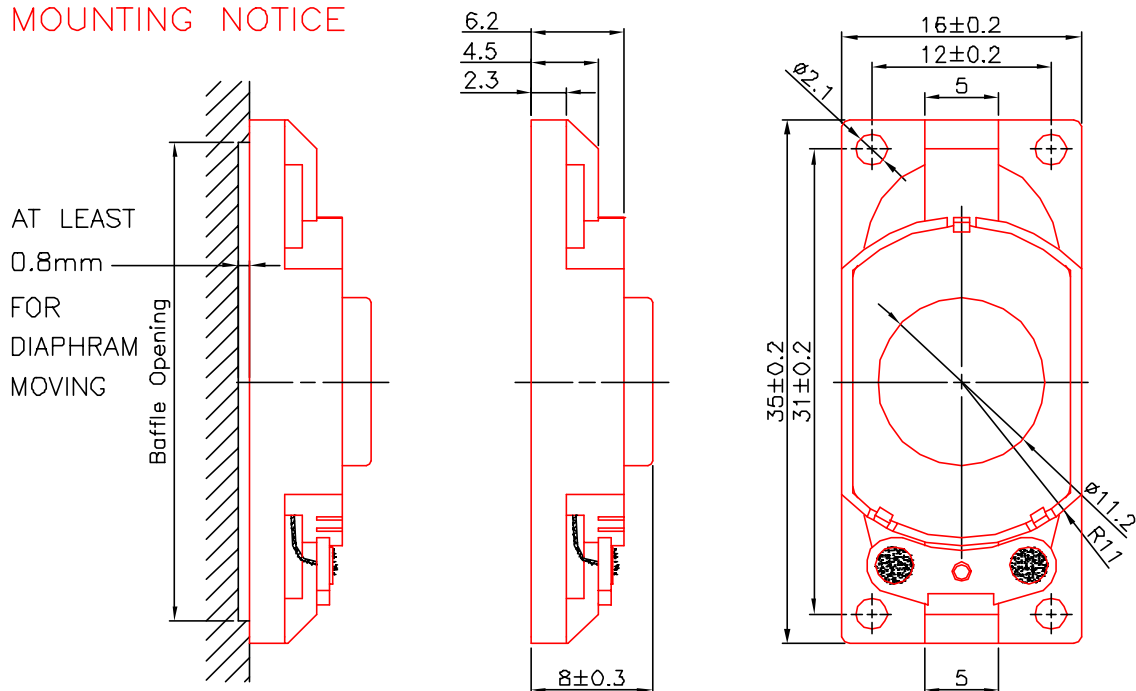

Unit : mm

Housing Material : PBT

35KPO8 VOL:2.828V(1.0W) DIS:0.5M VANSONIC
X:1.0000kHz *Y:82.59dB ZA:Live Curve SSR Fund.

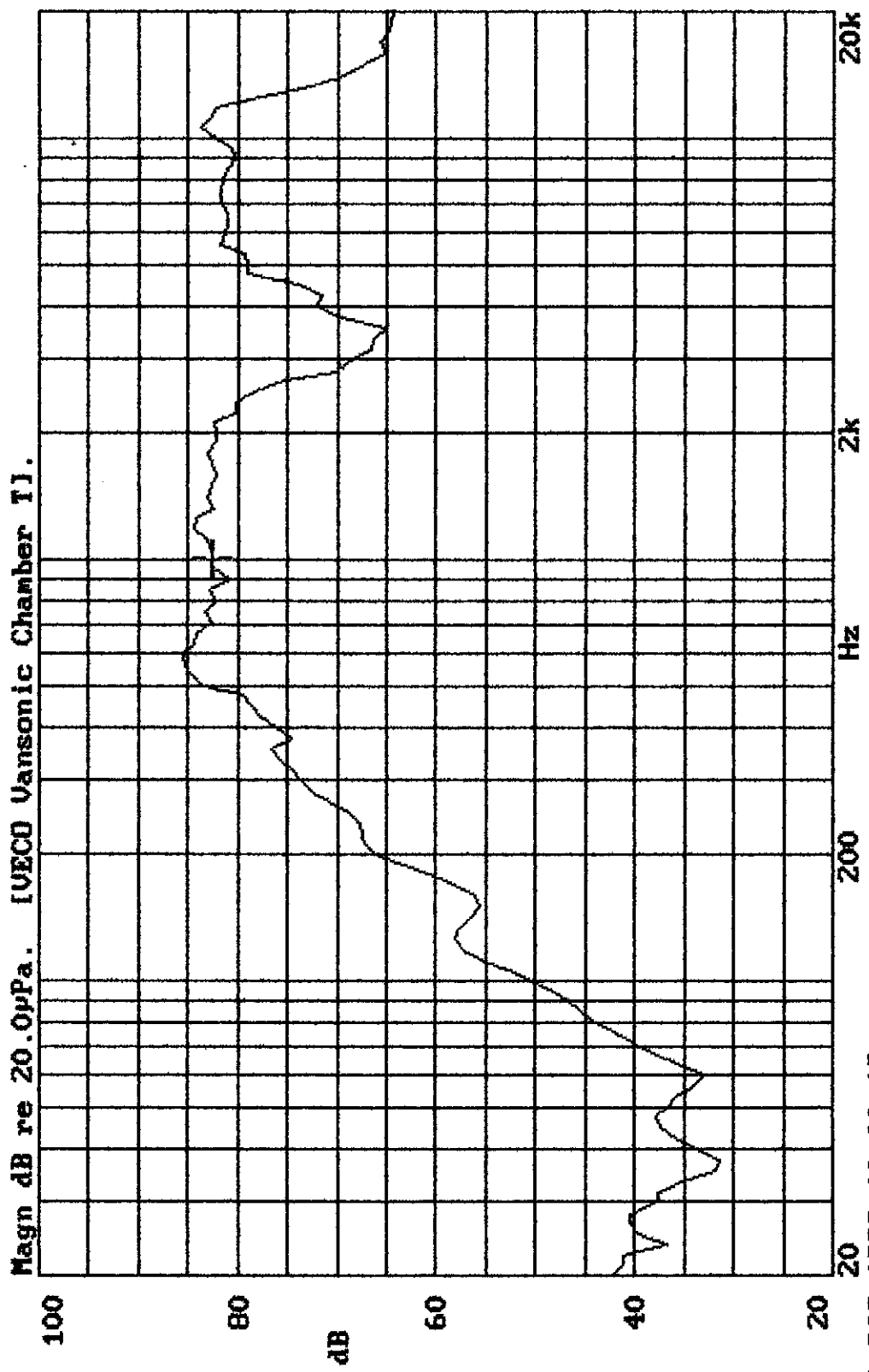

01-OCT-1999 16:06:18

Mode: SPEAKER

