

Motion Control Integrated Circuit

TMC 249

NEW!
Sensorless
Stall Detection

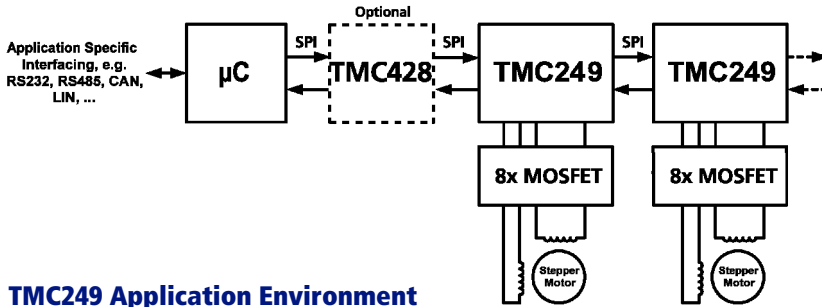

TMC249 Application Environment

High Current Microstep Stepper Motor Driver with Sensorless Stall Detection, Protection / Diagnosis and SPI Interface

The TMC249 is a dual full bridge driver IC for bipolar stepper motor control applications. The TMC249 is realized in a HVC-MOS technology and directly drives eight external Low-RDS-ON high efficiency MOSFETs. It supports up to 4000mA coil current. With additional drivers, motor current and voltage can be increased. The driver transistors can be chosen depending on output current or environment temperature. The integrated unique sensorless stall detection (pat.fi.) StallGuard™ makes it a good



choice for applications, where a reference point is needed, but where a switch is not desired. Its ability to predict an overload makes the TMC249 an optimum choice for drives, where a high reliability is desired. Internal DACs allow microstepping as well as smart current control. The device can be controlled by a serial interface (SPI™) or by analog / digital input signals. Short circuit, temperature, undervoltage and overvoltage protection are integrated.

SPI™ is a trademark of Motorola, Inc.

Features

- Drives 2-phase stepper motors
- Integrated load measurement allows sensorless stall detection (Pat. Fi.) StallGuard™
- Up to 10A and 75V with external circuitry
- 7V to 28.5V motor supply voltage
- Low power dissipation via external low RDS-ON power stage
- 4 bit DACs allow up to 16 times μ -stepping via SPI, higher resolution via analog control
- Control via SPI with easy to use 12 bit protocol or external analog / digital signals
- Status Flags for short circuit, open load, over temperature, temperature pre-warning, undervoltage
- Short circuit, over temperature, over voltage protection integrated
- Internal open load detector
- Mixed decay feature for smooth motor operation
- 3.3V or 5V operation for digital part
- Current control allows cool motor and driver operation
- Standby and shutdown mode available
- Slope control user programmable to reduce electromagnetic emissions
- Chopper frequency programmable via single capacitor or external clock
- Only 4 external PMOS transistors required for unipolar operation

TMC249 Block Diagram

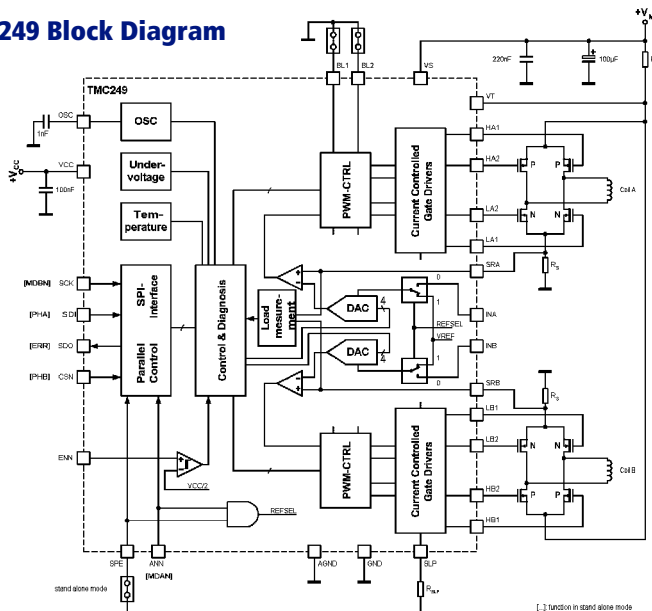

Motion Control Integrated Circuit

TMC 249



TRINAMIC
MICROCHIPS GMBH

Technical Specifications

Product Name	TMC249
Motors Controlled	2-phase bipolar stepper motors
Motor Current	depends on external transistors
μ -Step Resolution	4-bit DACs allow 16-64 \times μ -stepping
Temperature Range	-40°C to +140°C
Motor Supply Voltage	7V to 30V
Digital Operating Voltage	3V to 5.5V
Inputs	SPI / external analog current
SPI Datagram Length	12 bit
Internal DAC Resolution	4 bit / linear
Supply Current Digital	typ. 0.8mA
Shutdown Current	typ. 28 μ A
Output Slope Control	freely programmable:50ns - 500ns
Available Packages	SO28
Evaluation Kit	available

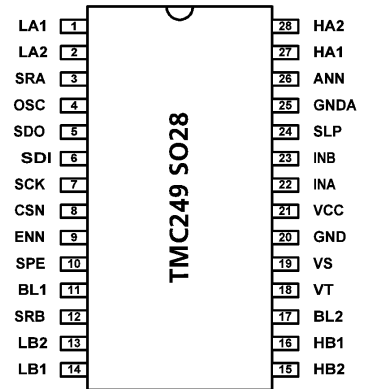

TMC 249 SO28 Pinout

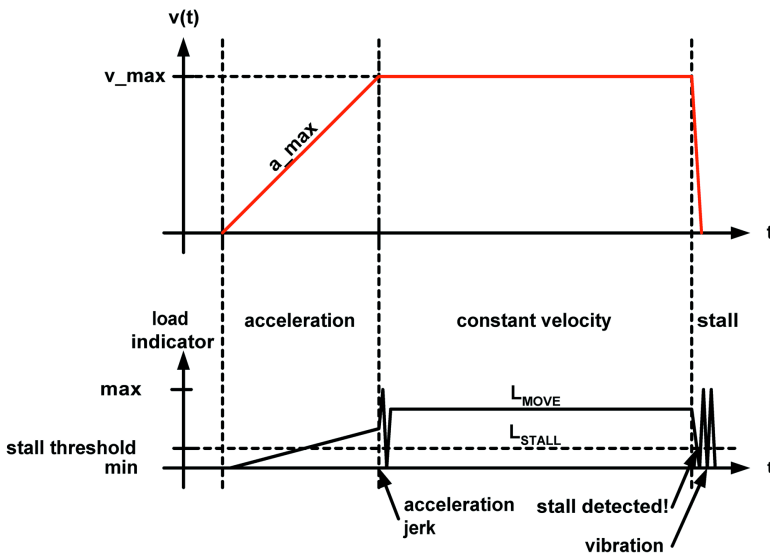

TMC249 Stall Detection Ramp

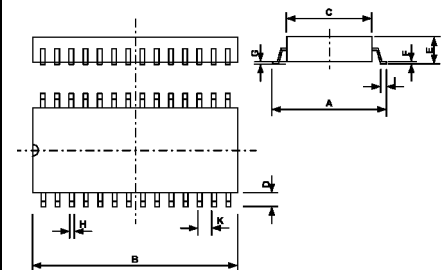

REF	MIN.	MAX.
A	10	10.65
B	17.7	18.1
C	7.4	7.6
D		1.4
E		2.65
F		0.25
G	0.1	0.3
H	0.36	0.49
I	0.4	1.1
K		1.27

TMC 249 SO28 Dimensional Specifications

Ordering Information

ORDER CODE	DESCRIPTION
TMC249-A	TMC249-SO28
TMC249-EVAL	TMC249 Evaluation Kit

This datasheet has been downloaded from:

www.DatasheetCatalog.com

Datasheets for electronic components.