

THIS DRAWING IS UNPUBLISHED. RELEASED FOR PUBLICATION DEC ,2004.
 © COPYRIGHT 2004 By - ALL RIGHTS RESERVED.

LOC		DIST		REVISIONS			
P	LTR	DESCRIPTION	DATE	DWN	APVD		
G1		REVISED PER ECO-13-012960	13NOV2013	RZ	MY		
1.1		9-1478242-0 UTP CAROL CABLE #06348A or EQUIVALENT				5-1634500-5	
1.1		9-1478242-0 UTP CAROL CABLE #06348A or EQUIVALENT				5-1634500-4	
1.1		9-1478242-0 RG58C/U, 141A/U, 303/U, URM43, 76, BELDEN 9907, KX15				5-1634500-3	
1.1		9-1478242-0 RG58C/U, 141A/U, 303/U, URM43, 76, BELDEN 9907, KX15				5-1634500-2	
0.57		9-1478242-0 RG174A/U, 188A/U, 316/U, URM95, KX3B, KX22A				5-1634500-1	
0.57		9-1478242-0 RG174A/U, 188A/U, 316/U, URM95, KX3B, KX22A				5-1634500-0	
A		DIE SET					PART NO.

NOTES

- 1 SINGLE PACK IN ACCORDANCE WITH AMP SPEC 107-3275
- 2 100 BODIES IN A HEAT SEALED BAG; 100 CONTACTS IN SEPARATE HEAT SEALED BAG; 100 CRIMP SLEEVES IN A SEPARATE HEAT SEALED BAG. ALL THREE BAGS WOULD BE PLACED IN A LABELED UNIT CONTAINER TO MAKE A PACKAGE OF 100 COMPLETE KITS.
- 3 GOLD PLATING
- 4 NICKEL PLATING
- 5 HAND TOOL: 9-1478240-0
- 6 DIE SET: SEE TABLE
- 7 FOR TECHNICAL DATA REFER TO YOUR LOCAL TE CONNECTIVITY SALES OFFICE
- 8 ALL DIMENSIONS ARE NOMINAL FOR REFERENCE ONLY UNLESS OTHERWISE STATED

DIMENSIONS		CABLE GROUPS		PART NO.

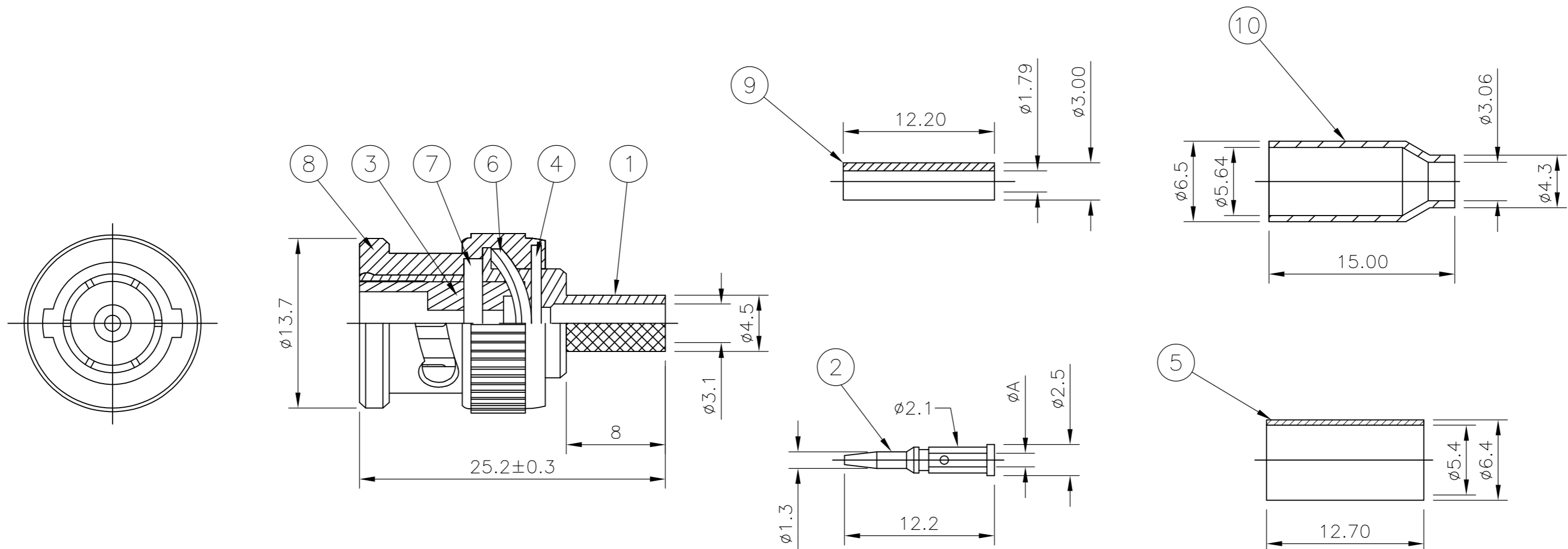

OBSOLETE

QTY	QTY PER ASSY	PARTS LIST	ITEM
1	1	BRASS	CRIMP SLEEVE
1	1	NYLON	PUSHER SLEEVE
1	1	ZINC ALLOY	BARREL
1	1	SILCON RUBBER	GASKET
1	1	SPRING STEEL	SPRING
1	1	BRASS	CRIMP SLEEVE
1	1	BRASS	WASHER
1	1	POLYMETHYLPENTENE	INSULATOR
1	1	BRASS	CONTACT
1	1	ZINC ALLOY	BODY
5	5	MATERIAL	DESCRIPTION
4	4		
5	5		
3	3		
1	1		

THIS DRAWING IS A CONTROLLED DOCUMENT.

DWN J.SANDWELL 23FEB04
 CHK S.PARLOW 23FEB04
 APVD F.WHEELER-KING 23FEB04

TE Connectivity
TE
 BNC STRAIGHT PLUG HEX CRIMP
 50 OHM

PRODUCT SPEC 108-112000
 APPLICATION SPEC SEE SHEET 2

MATERIAL SEE TABLE
 FINISH SEE TABLE

WEIGHT -
 CUSTOMER DRAWING

SIZE A2 CAGE CODE 00779 DRAWING NO. C=1634500 RESTRICTED TO -
 SCALE NTS SHEET 1 of 2 REV G1

THIS DRAWING IS UNPUBLISHED. RELEASED FOR PUBLICATION DEC ,2004.
 © COPYRIGHT 2004 By - ALL RIGHTS RESERVED.

LOC	DIST	REVISIONS					
E	B	P	LTR	DESCRIPTION	DATE	DWN	APVD
		-		SEE SHEET 1	-	-	-

COMPONENTS

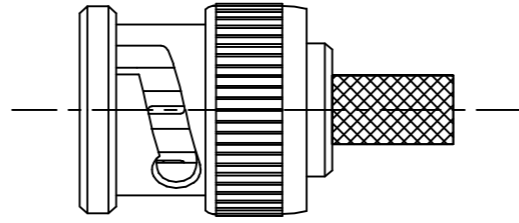
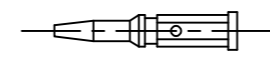
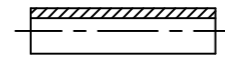
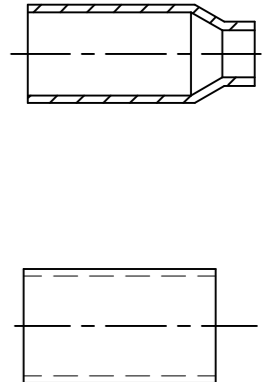
MAIN BODY (ITEM 1,3,4,6,7 & 8)	CENTRE CONTACT (ITEM 2)	PUSHER SLEEVE (ITEM 9)	CRIMP FERRULES (ITEM 5 & 10)
			

ASSEMBLY INSTRUCTION

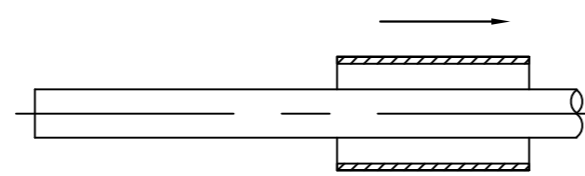
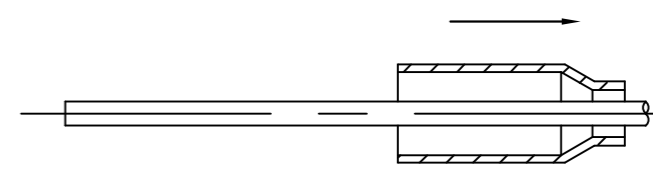
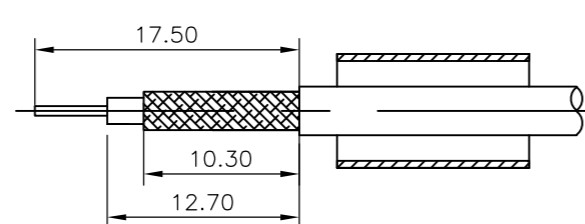
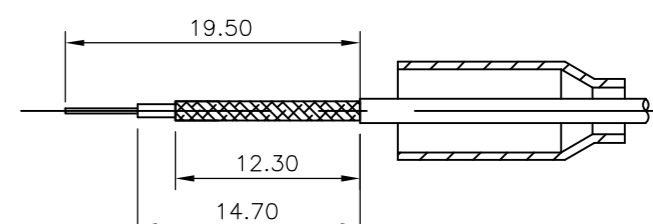
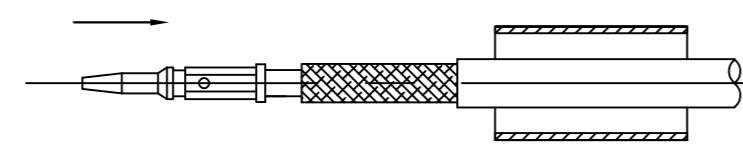
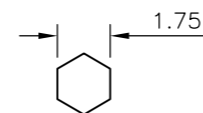
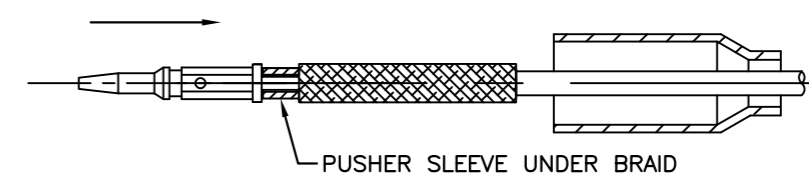
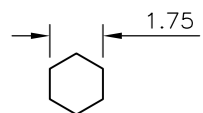
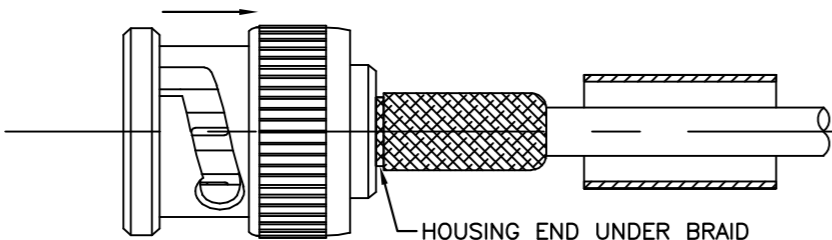
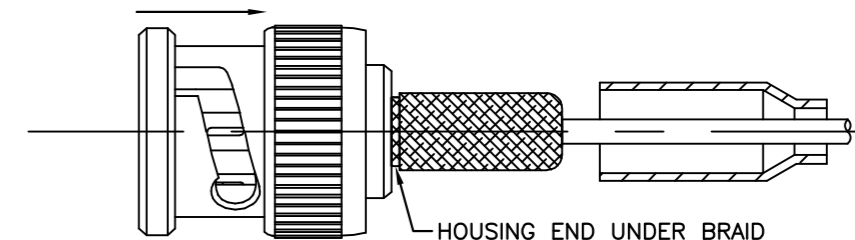
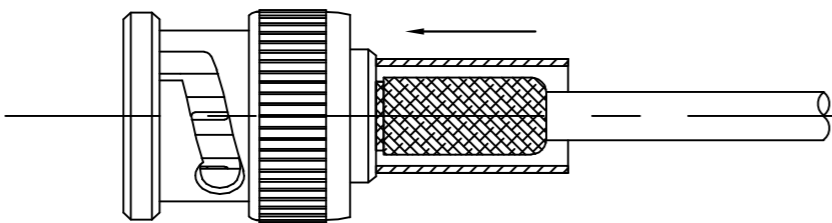
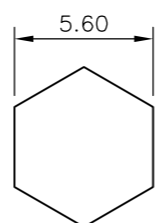
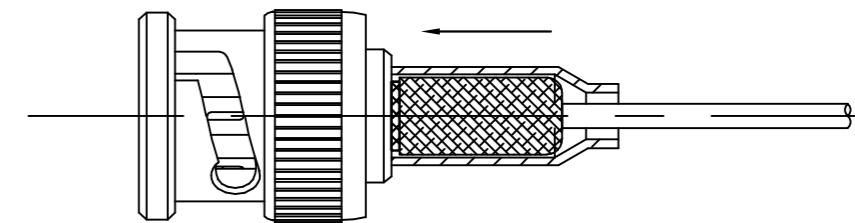
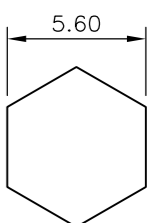
CABLES: RG58C/U, 141A/U, 303/U, URM43, 76, BELDEN 9907, KX15	CABLES: RG174A/U, 188A/U, 316/U, URM95, KX3B, KX22A, UTP CAROL CABLE #C6348A
<p>STEP 1</p> <p>1. SLIDE METAL CRIMP FERRULE OVER CABLE</p> 	<p>STEP 1</p> <p>1. SLIDE METAL CRIMP FERRULE OVER CABLE</p> 
<p>STEP 2</p> <p>1. STRIP CABLE TO DIMENSIONS AS SHOWN</p> 	<p>STEP 2</p> <p>1. STRIP CABLE TO DIMENSIONS AS SHOWN</p> 
<p>STEP 3</p> <p>1. FIT CONTACT OVER CENTRE CONDUCTOR TO BUTT AGAINST DIELECTRIC. 2. CRIMP USING TOOL AS NOTES ON PAGE 1.</p>  <p>RECOMMENDED CENTRE CONTACT A/F HEX</p> 	<p>STEP 3</p> <p>1. SLIDE ITEM 9 PUSHER SLEEVE OVER DIELECTRIC BEFORE FITTING THE CONTACT. NO PUSHER SLEEVE IS NEEDED FOR 5-1634500-4 & 5-1634500-5. 2. FIT CONTACT OVER CENTRE CONDUCTOR TO BUTT AGAINST DIELECTRIC. 3. CRIMP USING TOOL AS NOTES ON PAGE 1.</p>  <p>PUSHER SLEEVE UNDER BRAID</p> <p>RECOMMENDED CENTRE CONTACT A/F HEX</p> 
<p>STEP 4</p> <p>1. PRESS SUB-ASSEMBLY INTO BODY, UNTIL CONTACT IS FULLY LOCATED BY AN AUDIBLE CLICK. 2. ENSURE THAT KNURLED HOUSING INSERTS BETWEEN THE DIELECTRIC AND CABLE BRAID.</p>  <p>HOUSING END UNDER BRAID</p>	<p>STEP 4</p> <p>1. PRESS SUB-ASSEMBLY INTO BODY, UNTIL CONTACT IS FULLY LOCATED BY AN AUDIBLE CLICK. 2. ENSURE THAT KNURLED HOUSING INSERTS BETWEEN THE PUSHER SLEEVE AND CABLE BRAID.</p>  <p>HOUSING END UNDER BRAID</p>
<p>STEP 5</p> <p>1. SLIDE CRIMP FERRULE ALONG THE CABLE UNTIL IT BUTTS AGAINST THE HOUSING BODY. 2. CRIMP USING TOOL AS NOTED ON PAGE 1. 3. CRIMP DIMENSION AS SHOWN.</p>  <p>RECOMMENDED CRIMP SLEEVE A/F HEX</p> 	<p>STEP 5</p> <p>1. SLIDE CRIMP FERRULE ALONG THE CABLE UNTIL IT BUTTS AGAINST THE BODY HOUSING. 2. CRIMP USING TOOL AS NOTED ON PAGE 1. 3. CRIMP DIMENSION AS SHOWN.</p>  <p>RECOMMENDED CRIMP SLEEVE A/F HEX</p> 

THIS DRAWING IS A CONTROLLED DOCUMENT.		DWN J.SANDWELL 23FEB04	 TE Connectivity	
DIMENSIONS: MM		CHK S.PARLOW 23FEB04		
		APVD F.WHEELER-KING 23FEB04	PRODUCT SPEC	
TOLERANCES UNLESS OTHERWISE SPECIFIED		108-112000		
0 PLC ± 1 PLC ± 2 PLC ± 3 PLC ± 4 PLC ± ANGLES ±		APPLICATION SPEC		
MATERIAL SEE TABLE		SHEET 2		
FINISH SEE TABLE		WEIGHT -		
		CUSTOMER DRAWING		
		SCALE NTS		
		SHEET 2 OF 2		
		REV G1		

1634500

A