



Withdrawn Products

The following products presented in this data sheet are being withdrawn:

B65671D0000R026

Date of withdrawal: 02-AUG-02

Deadline for last orders: 31-DEC-02

Last shipments: 31-DEC-02

For further information please contact your nearest EPCOS sales office, which will also support you in selecting a suitable substitute. The addresses of the sales offices are given on the Internet at www.epcos.com/sales.

P 26 × 16

Core

B65671

- In accordance with IEC 60133
- Pot cores are supplied in sets

Magnetic characteristics (per set)

	with center hole	without center hole	
$\Sigma//A$	0,4	0,37	mm ⁻¹
l_e	37,2	40	mm
A_e	93	108	mm ²
A_{min}	76,5	87	mm ²
V_e	3460	4320	mm ³

Approx. weight (per set)

m	21	23	g

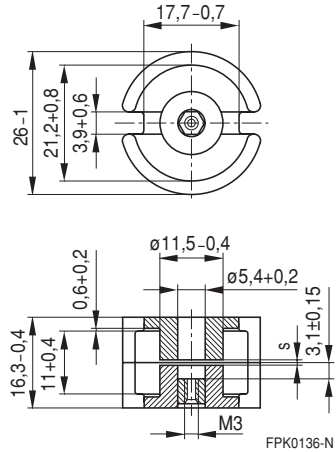

Gapped

Material	A_L value nH	s approx. mm	μ_e	Ordering code ¹⁾ -D with center hole -T with threaded sleeve
K1	100 ± 3 %	0,90	32	B65671-+100-A1
M33	100 ± 3 %	1,52	32	B65671-+100-A33
	160 ± 3 %	0,78	51	B65671-+160-A33
N48	160 ± 2 %	0,80	51	B65671-+160-G48
	250 ± 2 %	0,40	80	B65671-+250-G48
	315 ± 2 %	0,34	100	B65671-+315-G48
	400 ± 3 %	0,24	127	B65671-+400-A48
	630 ± 3 %	0,15	201	B65671-+630-A48
	800 ± 3 %	0,11	255	B65671-+800-A48
	1000 ± 5 %	0,10	319	B65671-D1000-J48

Ungapped

Material	A_L value nH	μ_e	A_{L1min} nH	P_V W/set	Ordering code -D with center hole -W without center hole
N26	4900 + 30/- 20 %	1560			B65671-D-R26
N30	9700 + 30/- 20 %	2860			B65671-W-R30
T38	22000 + 40/- 30 %	6480			B65671-W-Y38
N87	5500 + 30/- 20 %	1620	3050	< 1,9 (200 mT, 100 kHz, 100 °C)	B65671-W-R87

1) Replace the + by the code letter "D" or "T" for the required version.

Coil former

Standard: to IEC 60133

Material: GFR polyterephthalate (UL 94 V-0, insulation class to IEC 60085:

F \triangleq max. operating temperature 155 °C), color code black

Winding: see "Processing Notes", page 155

Insulating washer 1 between core and coil former

- For tolerance compensation and for insulation
- Polycarbonate spring washer (UL 94 V-0, insulation class to IEC 60085: E \triangleq 120 °C), 0,06 mm thick

Insulating washer 2 between core and terminal carrier

- For increased dielectric strength
- Made of polycarbonate (UL 94 V-0, insulation class to IEC 60085: E \triangleq 120 °C), 0,08 mm thick

Coil former				Ordering code
Sections	A_N mm ²	l_N mm	A_R value $\mu\Omega$	
1	32,0	52	55	B65672-B-T1
Insulating washer 1 (reel packing, PU = 1 reel)				B65672-B5000
Insulating washer 2 (bulk)				B65672-A5002

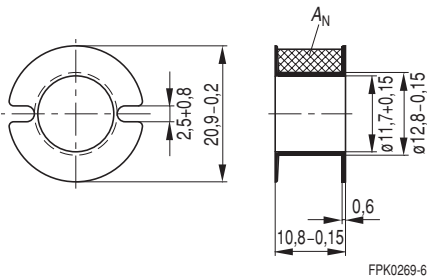
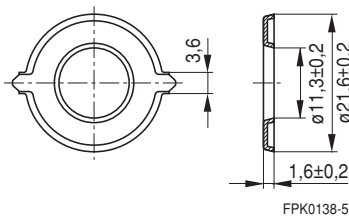
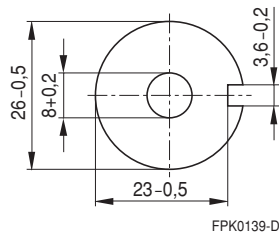
Coil former

Insulating washer 1

Insulating washer 2

Mounting assembly for printed circuit boards

- The set comprises a terminal carrier and a yoke
- For snap-in connection

Terminal carrier

Material: GFR polyterephthalate (UL 94 V-0, insulation class to IEC 60085:
F \triangleq max. operating temperature 155 °C), color code gray

Solderability: to IEC 60068-2-20, test Ta, method 1 (aging 3): 235 °C, 2 s

Resistance to soldering heat: to IEC 60068-2-20, test Tb, method 1B: 350 °C, 3,5 s

Yoke

Spring yoke, made of tinned nickel silver (0,4 mm), with ground terminal

Complete mounting assembly (8 solder terminals)

Ordering code: B65675-B5

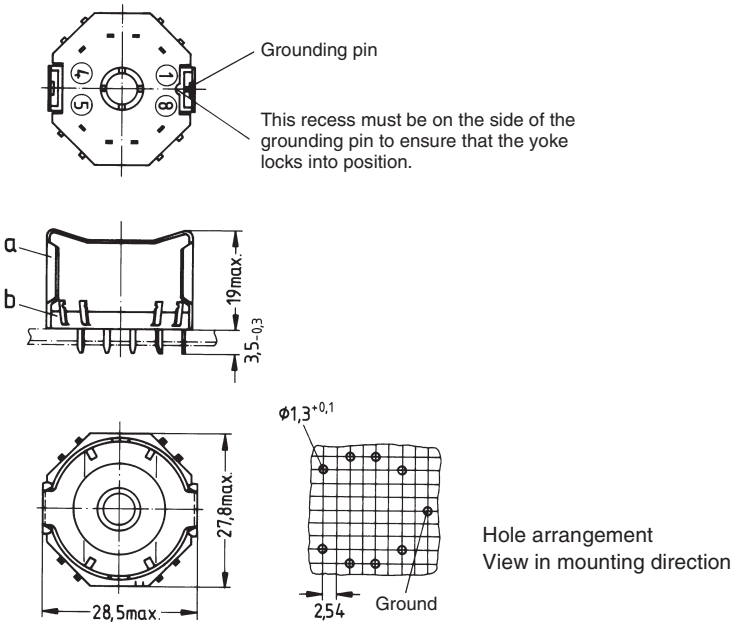

FPK0140-G

- a) Yoke
b) Terminal carrier with 8 solder terminals

P 26 × 16	B63399
Accessories	B65679

Adjusting screw

- Tube core with thread and core brake made of GFR polyterephthalate
- Plastic **adjusting screwdriver** (not shown)
- Plastic **handle** for adjusting screwdriver (not shown)

Core P 26 × 16		Adjusting screw			Min. adjusting range %	Ordering code
Material	A _L value nH	Tube core ∅ × length mm	Material	Color code		
N 48	250 315	4,55 × 6,3	N 22	red	16 13	B65679-E3-X22
	315 400	4,98 × 6,3	N 22	black	23 18	B65679-E2-X22
	630 800	5,15 × 6,3	N 22	white	16 14	B65679-E1-X22
Adjusting screw						B63399-B1
Handle						B63399-B5

Adjusting screw ¹⁾

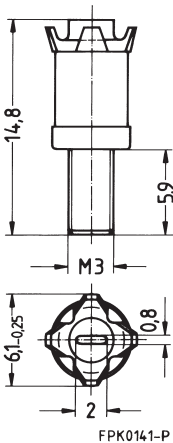

1) Due to the limited distance between adjusting screw and internal borehole, the entire assembly must be accurately centered.

Herausgegeben von EPCOS AG

Marketing Kommunikation, Postfach 80 17 09, 81617 München, DEUTSCHLAND

© EPCOS AG 2000. Alle Rechte vorbehalten. Vervielfältigung, Veröffentlichung, Verbreitung und Verwertung dieser Broschüre und ihres Inhalts ohne ausdrückliche Genehmigung der EPCOS AG nicht gestattet.

Mit den Angaben in dieser Broschüre werden die Bauelemente spezifiziert, keine Eigenschaften zugesichert. Bestellungen unterliegen den vom ZVEI empfohlenen Allgemeinen Lieferbedingungen für Erzeugnisse und Leistungen der Elektroindustrie, soweit nichts anderes vereinbart wird.

Diese Broschüre ersetzt die vorige Ausgabe.

Fragen über Technik, Preise und Liefermöglichkeiten richten Sie bitte an den Ihnen nächstgelegenen Vertrieb der EPCOS AG oder an unsere Vertriebsgesellschaften im Ausland.

Bauelemente können aufgrund technischer Erfordernisse Gefahrstoffe enthalten. Auskünfte darüber bitten wir unter Angabe des betreffenden Typs ebenfalls über die zuständige Vertriebsgesellschaft einzuholen.

Published by EPCOS AG

Marketing Communications, P.O. Box 80 17 09, 81617 Munich, GERMANY

© EPCOS AG 2000. All Rights Reserved. Reproduction, publication and dissemination of this brochure and the information contained therein without EPCOS' prior express consent is prohibited.

The information contained in this brochure describes the type of component and shall not be considered as guaranteed characteristics. Purchase orders are subject to the General Conditions for the Supply of Products and Services of the Electrical and Electronics Industry recommended by the ZVEI (German Electrical and Electronic Manufacturers' Association), unless otherwise agreed.

This brochure replaces the previous edition.

For questions on technology, prices and delivery please contact the Sales Offices of EPCOS AG or the international Representatives.

Due to technical requirements components may contain dangerous substances. For information on the type in question please also contact one of our Sales Offices.