

# FELLER GMBH

A-2525 GUENSELSDORF, AUSTRIA - TEL.: .. 43(2256) 62 32 50 - FAX: .. 43 (2256) 62 32 57  
e-mail: sales@feller-at.com <http://www.feller-at.com>

## Description: HG/TR-SJT3x16AWG-C13M/3,05m,black

(L71B)

Rating of cord set: 13A/125 Vac

### 1. PLUG: Type HG/TR (transparent)

Molded plug according to : NEMA 5-15 (HOSPITAL GRADE)  
Rated current and voltage : 15 A, 125 V AC  
Plugbase : thermoplastic Polyester (PBTP) GFR  
Pins : solid,brass,nickel-plated,crimped  
Pins dimension : grounding O.D. 4,8 mm  
line and neutral 6,20 mm x 1,40 mm  
Outer mold : PVC compound, hardness Shore A 89 +/- 3  
Approvals : UL,CSA

### 2. CORD: Type SJT3X16AWG

Flexible cord according to : UL 62,CSA 22.2 No.49  
Marking : \*JF\* E41542\*SJT3x16AWG\*FT2\*UL\*CSA\*60C\*300V\*  
Number of cores : 3  
Conductor construction : 27x0,254, O.D. 1,58 mm  
Conductor insulation : Extruded PVC, O.D. 3,20  
Jacket : Extruded PVC, o.D. 8,60mm, +/-0,30mm  
Electrical resistance of conductors : 14,06  $\Omega$ /km  
Dielectric strength : 2kVac, 1min.  
Insulation resistance : >0,010Mohm/km  
Color of conductors : green,black,white  
Approvals : UL,CSA

### 3. CONNECTOR: Type C13M

Molded connector according to : EN/IEC 60320/C13, UL 817,C22.2 No. 21  
Rated current and voltage : 13 A, 250 V AC  
Construction : double insulation  
Contacts of the connection : self-adjusting phosphor bronze CuSn6  
Inner insulation : PPO GFR  
Outer mold : PVC compound, hardness Shore A 75-77  
Approvals : ENEC,UL,CSA

Environmental conformity : EU-Directive 2002/96/EC (WEEE)  
EU-Directive 2003/11/EC (Council Directive 76/769/EEC)  
EU-Directive 2002/95/EC (RoHS-compliant)

### TESTING

Electrical testing : 100%  
Visual inspection : 100%  
High pot test wire to wire : 3.000Vac for 2 sec.  
Continuity test : 25Aac to grounding / 20Aac to line and neutral  
Polarity test : yes  
Skin high pot test : 6.000Vac line to skin

Tolerances not indicated in the drawing: +/- 2 %  
design subject to change without prior notice

DATE of ISSUE:	August, 2010		
REV: 3	1	ORIG:	mk

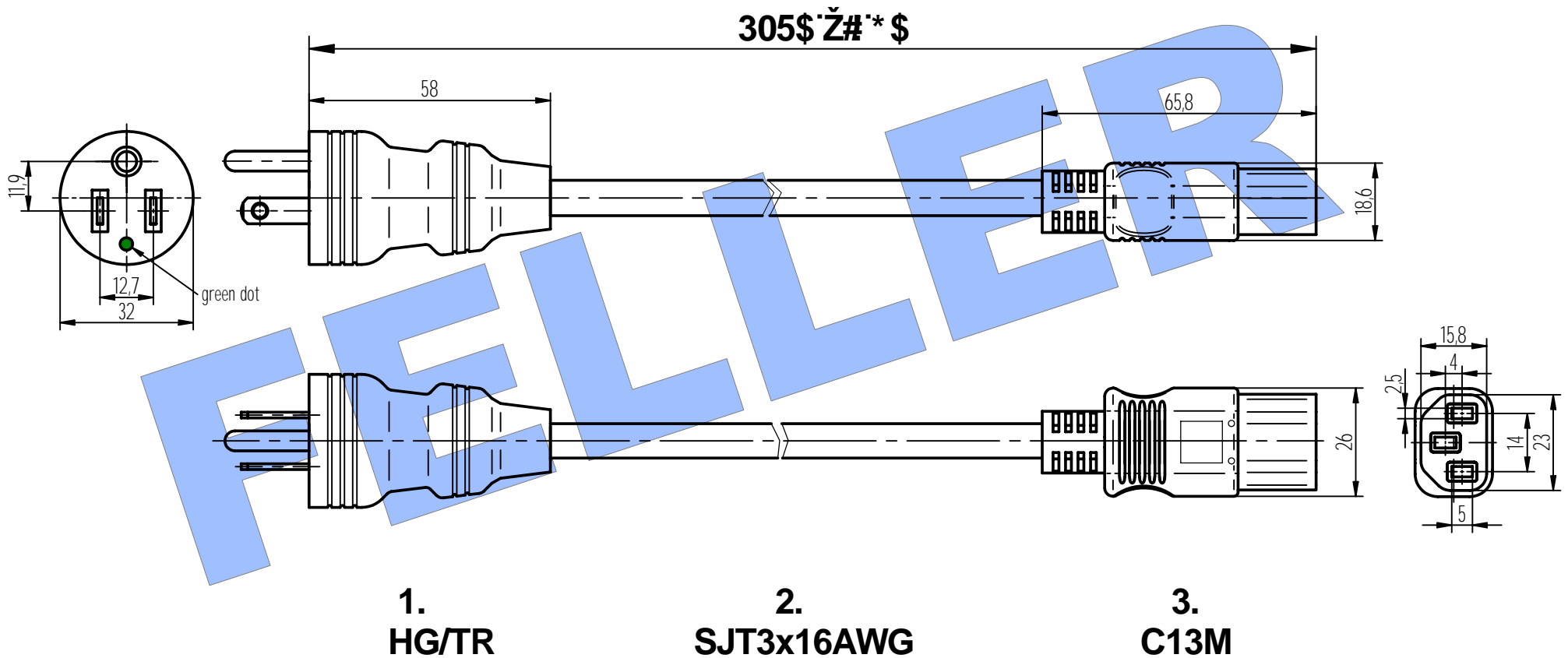

**Feller Type:** HG/TR-SJT3x16AWG-C13M / 3,05mžblack (L71B)

**RoHS compliant**

2) .0, .%\$

**All dimensions in mm**

**FELLER** 

A-2525 Günselsdorf, Austria

Telefon 0043-2256-62325-0

Fax: 0043-2256-62325-7

email: sales@feller-at.com

http://www.feller-at.com