

Flansch vorne, Chassis
an Frontplatten-Rueckseite
flange at frontside,
chassis at frontpanel-rearside

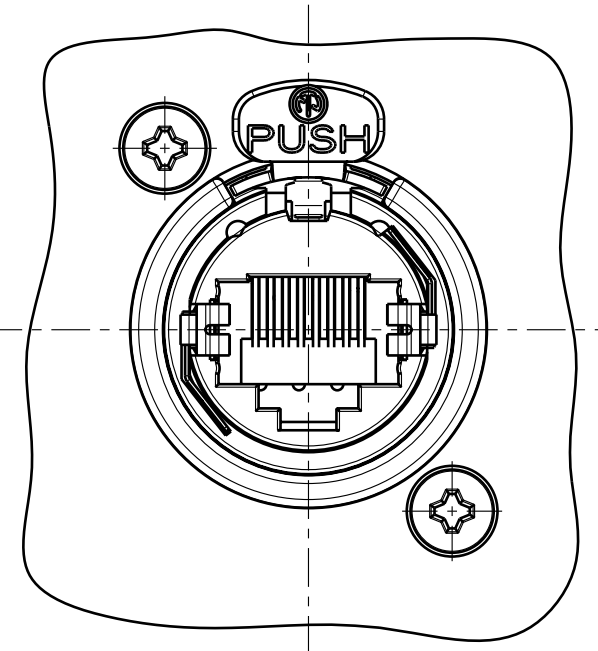

Flansch u. Chassis
an Frontplatten-Rueckseite
flange and chassis fixed
at frontpanel-rearside

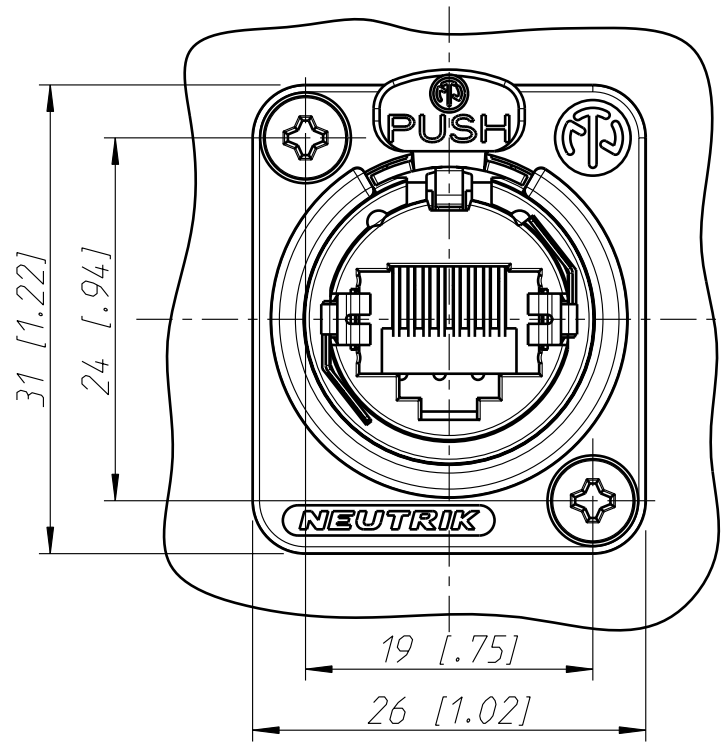
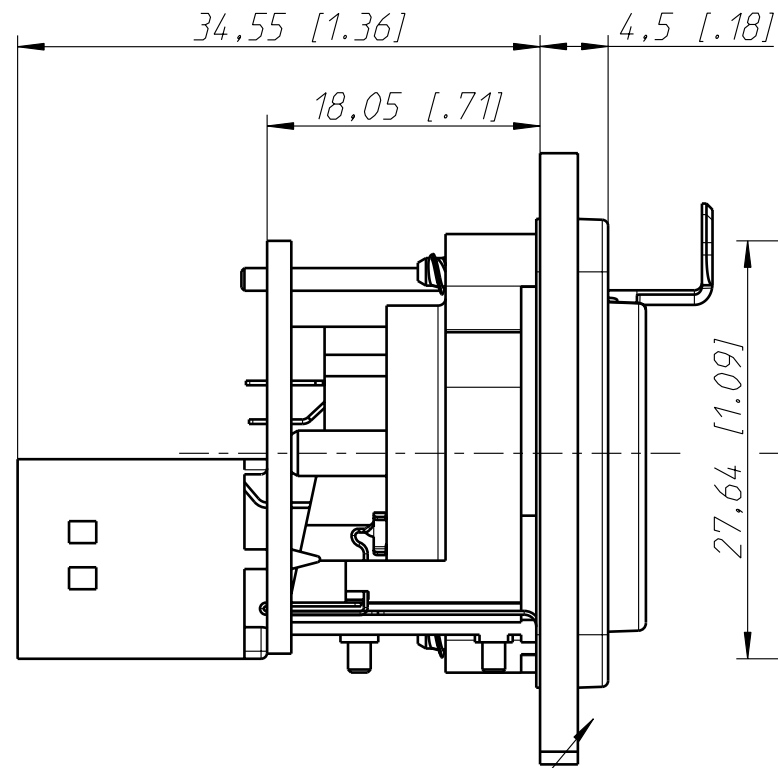

Frontplatte
frontpanel

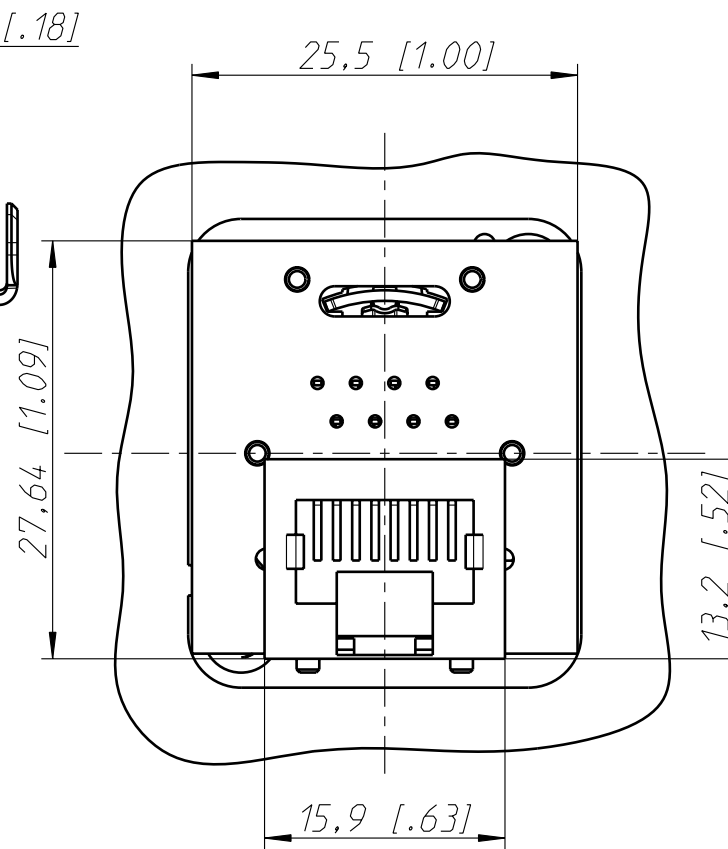
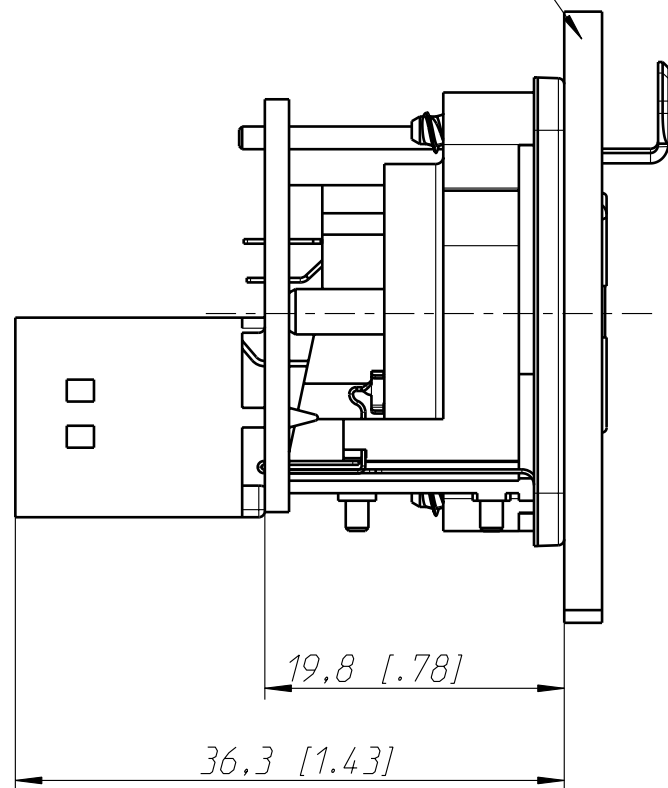

Frontplattenausschnitt (Rueckseite)
Panel cut out (rear side)

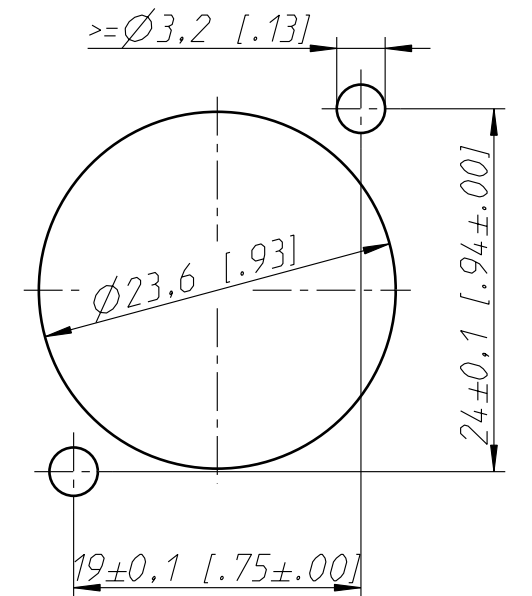

Component-Compliance CAT5E according to TIA/EIA 568B.2

Allgemeintoleranzen ISO 2768-m	Werkstoff KEIN_MAT	Massstab: 2:1 (A3)	Gezeichnet	Datum	Name
			Freigegeben	03.12.02	Payr
Zeichnung urheberrechtlich geschuetzt (DIN 34) (C)	-	-	Geaendert	-	-
			04.02.05	Payr	
Benennung			Aend.-Nr.	Aend.-Index	
- NE8FDP			18-2005	B	
			Ersatz fuer:	Blatt 1 von 1 Bl.	
NEUTRIK AG FL-9494 SCHAAN			Zeichn. Nr.	ST-NE8FDP	