

■ **XCK J**
fixed body with 1 cable entry

□ With head for linear movement (plunger)

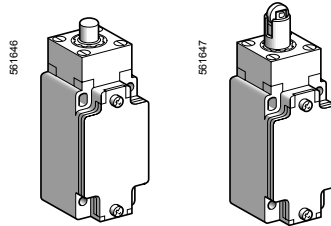

Page 1/102

□ With head for rotary movement (lever)

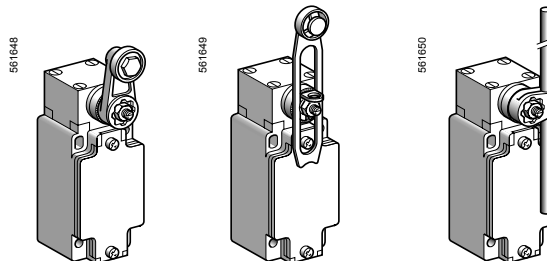

Page 1/102

■ **XCK J**
plug-in body with 1 cable entry

□ With head for linear movement (plunger)

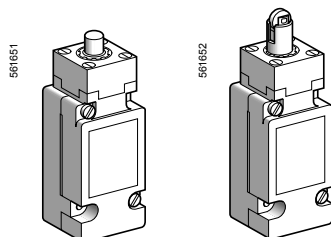

Page 1/104

□ With head for rotary movement (lever)

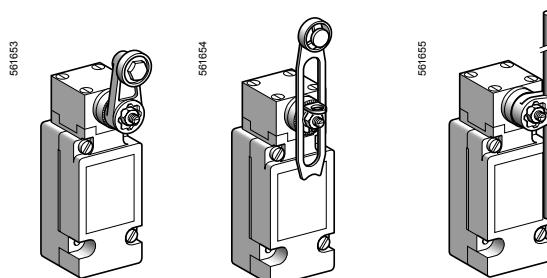

Page 1/104

Environment characteristics

Conformity to standards	Products	IEC 60947-5-1, EN 60947-5-1, UL 508, CSA C22-2 n° 14
	Machine assemblies	IEC 60204-1, EN 60204-1
Product certifications		UL, CSA, CCC
Protective treatment	Version	Standard: "TC", special: "TH"
Ambient air temperature	For operation	- 25...+ 70°C, special sub-assemblies for use at - 40°C or + 120°C
	For storage	- 40...+ 70°C
Vibration resistance	Conforming to IEC 60068-2-6	25 gn (10...500 Hz)
Shock resistance	Conforming to IEC 60068-2-27	50 gn (11 ms)
Electric shock protection		Class I conforming to IEC 61140 and NF C 20-030
Degree of protection		IP 66 conforming to IEC 60529; IK 07 conforming to EN 50102
Repeat accuracy		0.01 mm on the tripping points, with 1 million operating cycles for head with end plunger
Cable entry or connector	Depending on model	Tapped entry for n° 13 cable gland, tapped ISO M20 x 1.5 or tapped 1/2" NPT, or M12 connector
Materials		Bodies and heads in zamak



Contact block characteristics		
Rated operational characteristics	XE2● P	~AC-15; A300 (Ue = 240 V, Ie = 3 A); Ithe = 10 A ---DC-13; Q300 (Ue = 250 V, Ie = 0.27 A), conforming to IEC 60947-5-1 Appendix A, EN 60947-5-1
	XE3● P	~AC-15; B300 (Ue = 240 V, Ie = 1.5 A); Ithe = 6 A ---DC-13; R300 (Ue = 250 V, Ie = 0.1 A), conforming to IEC 60947-5-1 Appendix A, EN 60947-5-1
Rated insulation voltage	XE2● P	Ui = 500 V degree of pollution 3 conforming to IEC 60947-1 Ui = 300 V conforming to UL 508, CSA C22-2 n° 14
	XE3● P	Ui = 400 V degree of pollution 3 conforming to IEC 60947-1 Ui = 300 V conforming to UL 508, CSA C22-2 n° 14
Rated impulse withstand voltage	XE2● P	U imp = 6 kV conforming to IEC 60947-1, IEC 60664
	XE3● P	U imp = 4 kV conforming to IEC 60947-1, IEC 60664
Positive operation (depending on model)		NC contacts with positive opening operation conforming to IEC 60947-5-1 Appendix K, EN 60947-5-1
Resistance across terminals		≤ 25 mΩ conforming to IEC 60255-7 category 3
Short-circuit protection	XE2● P	10 A cartridge fuse type gG (gl)
	XE3● P	6 A cartridge fuse type gG (gl)
Connection (screw clamp terminals)	XE2S P21●1	Clamping capacity, min: 1 x 0.34 mm ² , max: 2 x 1.5 mm ²
	XE2N P21●1	Clamping capacity, min: 1 x 0.5 mm ² , max: 2 x 2.5 mm ²
	XCK J plug-in and XES P20●1	Clamping capacity, min: 1 x 0.75 mm ² , max: 2 x 1.5 mm ²
	XE3N P and XE3S P	Clamping capacity, min: 1 x 0.34 mm ² , max: 1 x 1 mm ² or 2 x 0.75 mm ²
Minimum actuation speed		XE2S P21●1 and XE3S P: 0.01 m/minute
		XE2N P21●1 and XE3N P: 6 m/minute

Electrical durability

- Conforming to IEC 60947-5-1 Appendix C
- Utilisation categories AC-15 and DC-13
- Maximum operating rate: 3600 operating cycles/hour
- Load factor: 0.5

	XE2S P21●1, XE2S P2141	XE2N P21●1	XCK J plug-in, XES P20●1
AC supply 50/60 Hz ~ mm inductive circuit			
DC supply ---	Power broken in W for 5 million operating cycles. Voltage V 24 48 120 mm W 10 7 4	Power broken in W for 5 million operating cycles. Voltage V 24 48 120 mm W 13 9 7	Power broken in W for 5 million operating cycles. Voltage V 24 48 120 mm W 10 7 4
	For XE2S P●151 on ~ or ---, NC and NO contacts simultaneously loaded to the values shown with reverse polarity.		

	XE3S P●●●	XE3N P●●●
AC supply 50/60 Hz ~ mm inductive circuit		
DC supply ---	Power broken in W for 5 million operating cycles. Voltage V 24 48 120 mm W 3 2 1	Power broken in W for 5 million operating cycles. Voltage V 24 48 120 mm W 4 3 2

Limit switches





OsiSense XC Standard

Industrial format EN 50041



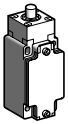
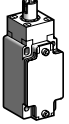
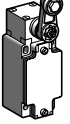

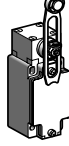





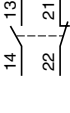
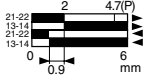
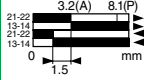
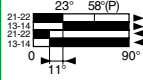
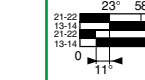

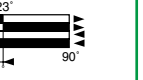
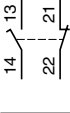
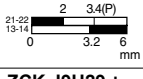
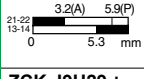
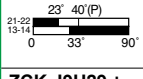
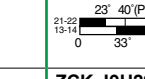

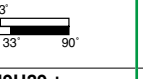
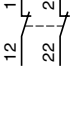



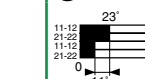

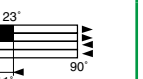
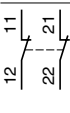
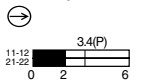
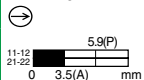
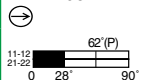
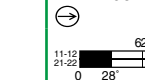

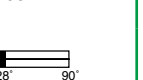
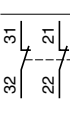

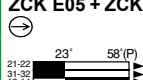
Metal, conforming to CENELEC EN 50041, type XCK J

Complete fixed body switches with 1 cable entry

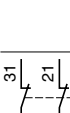
1

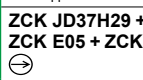
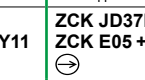
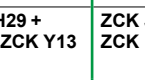
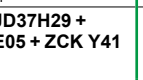
Type of head	Plunger (fixing by the body)		Rotary (fixing by the body) (switches supplied for actuation from left AND right)			
	Form B (1)	Form C (1)	Form A (1)			Form D (1)
						
Type of operator	Metal end plunger	Steel roller plunger	Thermoplastic roller lever (2)	Steel roller lever (2)	Variable length thermoplastic roller lever (2)	Round thermoplastic rod lever, Ø 6 mm (2) (4)

References of complete switches with 1 ISO M20 x 1.5 cable entry(3)

	2-pole NC + NO snap action (XE2S P2151)	XCK J161H29 	XCK J167H29 	XCK J10511H29 	XCK J10513H29 	XCK J10541H29 	XCK J10559H29 
	2-pole NC + NO break before make, slow break (XE2N P2151)	XCK J561H29 	XCK J567H29 	XCK J50511H29 	XCK J50513H29 	XCK J50541H29 	XCK J50559H29 
	2-pole NC + NC snap action (XE2S P2141)	ZCK J9H29 + ZCK E61 	ZCK J9H29 + ZCK E67 	ZCK J9H29 + ZCK E05 + ZCK Y11 	ZCK J9H29 + ZCK E05 + ZCK Y13 	ZCK J9H29 + ZCK E05 + ZCK Y41 	ZCK J9H29 + ZCK E05 + ZCK Y59 
	2-pole NC + NC simultaneous, slow break (XE2N P2141)	ZCK J7H29 + ZCK E61 	ZCK J7H29 + ZCK E67 	ZCK J7H29 + ZCK E05 + ZCK Y11 	ZCK J7H29 + ZCK E05 + ZCK Y13 	ZCK J7H29 + ZCK E05 + ZCK Y41 	ZCK J7H29 + ZCK E05 + ZCK Y59 
	3-pole NC + NC + NO snap action (XE3S P2141)	ZCK JD39H29 + ZCK E61 	ZCK JD39H29 + ZCK E67 	ZCK JD39H29 + ZCK E05 + ZCK Y11 	ZCK JD39H29 + ZCK E05 + ZCK Y13 	ZCK JD39H29 + ZCK E05 + ZCK Y41 	ZCK JD39H29 + ZCK E05 + ZCK Y59 
	3-pole NC + NC + NO break before make, slow break (XE3N P2141)	ZCK JD37H29 + ZCK E61 	ZCK JD37H29 + ZCK E67 	ZCK JD37H29 + ZCK E05 + ZCK Y11 	ZCK JD37H29 + ZCK E05 + ZCK Y13 	ZCK JD37H29 + ZCK E05 + ZCK Y41 	ZCK JD37H29 + ZCK E05 + ZCK Y59 
Weight (kg)	0.430	0.455	0.480	0.490	0.485	0.485	
Contact operation	 closed  open		(A) = cam displacement (P) = positive opening point			 NC contact with positive opening operation	

References of complete switches with 1 Pg 13.5 cable entry (2)

For complete switches with entry for Pg 13.5 cable gland, delete H29 from the end of the reference. Example: XCK J161H29 becomes XCK J161.

References of complete switches with 1 entry for 1/2" NPT conduit (2)

For complete switches with entry for 1/2" NPT (USAS B2-1) conduit, replace H29 at the end of the reference by H7. Example: XCK J161H29 becomes XCK J161H7.

(1) Form conforming to EN 50041, see page 1/177.

(2) Adjustable throughout 360° in 5° steps, or in 45° steps by reversing the lever or its mounting.

(3) Switches with gold contacts or eyelet type connections: please consult our Customer Care Centre.

(4) Value taken with actuation by moving part at 100 mm from the fixing.

Limit switches

OsiSense XC Standard

Industrial format EN 50041

Metal, conforming to CENELEC EN 50041, type XCK J

Complete fixed body switches with 1 cable entry

1

Characteristics

Switch actuation	On end	By 30° cam		By any moving part
Type of actuation				
Maximum actuation speed	0.5 m/s	1 m/s	1.5 m/s	
Mechanical durability (1) (in millions of operating cycles)	30	25	30	
Minimum force or torque	For tripping For positive opening	20 N 50 N	16 N 40 N	0.25 N.m 0.50 N.m
Cable entry (3)	1 entry tapped M20 x 1.5 mm for ISO cable gland, clamping capacity 9 to 12 mm			

(1) Limited to 15 million operating cycles for switches with contacts XE3●P.

Dimensions

XCK J●61H29
ZCK J● + ZCK E61

XCK J●67H29
ZCK J● + ZCK E67

XCK J●051●H29
ZCK J● + ZCK E05 + ZCK Y11 or Y13

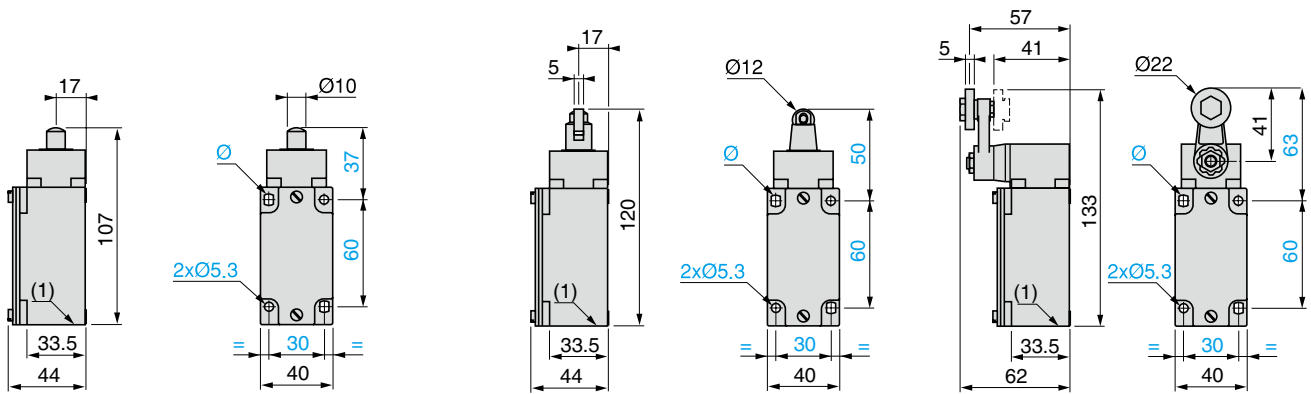

XCK J●0541H29
ZCK J● + ZCK E05 + ZCK Y41

XCK J●0559H29
ZCK J● + ZCK E05 + ZCK Y59

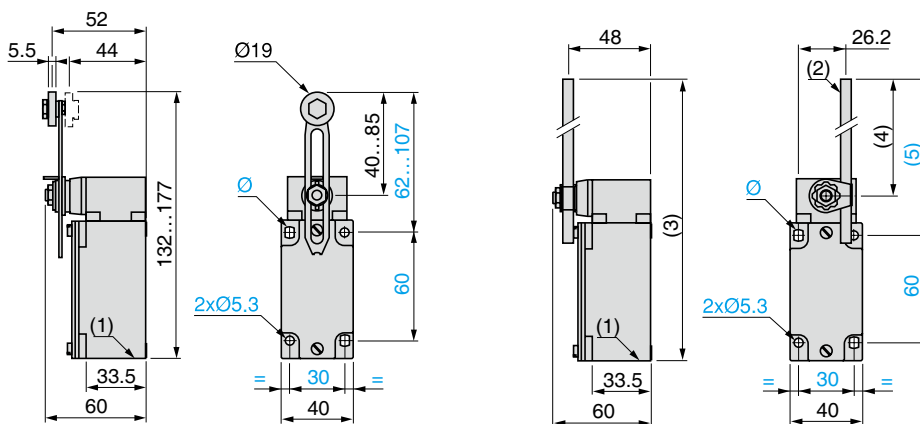

(1) 1 tapped entry for ISO M20 x 1.5 or Pg 13.5 cable gland or tapped 1/2" NPT.

(2) Ø 6 rod, length 200 mm.

(3) 282 max.

(4) 190 max.











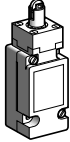

(5) 212 max.

Ø: 2 elongated holes Ø 5.3 x 7.3.

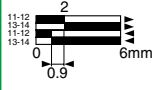
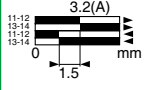
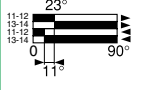
Limit switches

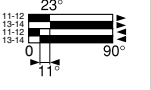
OsiSense XC Standard, industrial format EN 50041
Metal, conforming to CENELEC EN 50041, type XCK J
Complete switches, plug-in body
With 1 cable entry

1

Type of head	Plunger (fixing by the body)		Rotary (fixing by the body) (switches supplied for actuation from left AND right)			
	Form B (1)	Form C (1)	Form A (1)		Form D (1)	
						
Type of operator	Metal end plunger	Steel roller plunger	Thermoplastic roller lever (2)	Steel roller lever (2)	Variable length thermoplastic roller lever (2)	Round thermoplastic rod lever, Ø 6 mm (2) (4)
References of complete switches with 1 ISO M20 x 1.5 cable entry (3)						
 Single-pole CO snap action	XCK J1161H29	XCK J1167H29	XCK J110511H29	XCK J110513H29	XCK J110541H29	XCK J110559H29
						
Weight (kg)	0.430	0.455	0.480	0.490	0.485	0.485
Contact operation	 closed  open		(A) = cam displacement			



References of complete switches with 1 Pg 13.5 cable entry (3)

For complete switches with entry for Pg 13.5 cable gland, delete **H29** from the end of the reference.
Example: **XCK J1161H29** becomes **XCK J1161**.

References of complete switches with 1 entry for 1/2" NPT conduit (3)

For complete switches with entry for 1/2" NPT (USAS B2-1) conduit, replace **H29** at the end of the reference by **H7**.
Example: **XCK J1161H29** becomes **XCK J1161H7**.

Characteristics

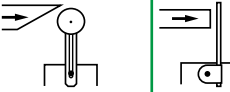
Switch actuation	On end	By 30° cam		By any moving part
Type of actuation				
Maximum actuation speed	0.5 m/s	1 m/s	1.5 m/s	
Mechanical durability (in millions of operating cycles)	30	25	30	
Minimum tripping force or torque	20 N	16 N	0.25 N.m	
Cable entry	1 entry tapped M20 x 1.5 for ISO cable gland Clamping capacity 7 to 13 mm			

- (1) Form conforming to EN 50041, see page 1/177.
 (2) Adjustable throughout 360° in 5° steps, or in 45° steps by reversing the lever or its mounting.
 (3) Switches with gold contacts: please consult our Customer Care Centre.
 (4) Value taken with actuation by moving part at 100 mm from the fixing.

Limit switches

OsiSense XC Standard, industrial format EN 50041
 Metal, conforming to CENELEC EN 50041, type XCK J
 Complete switches, plug-in body
 With 1 cable entry

1

XCK J1611H29

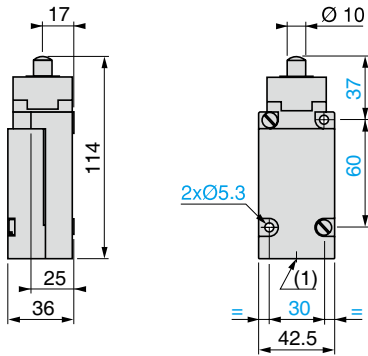

XCK J1167H29

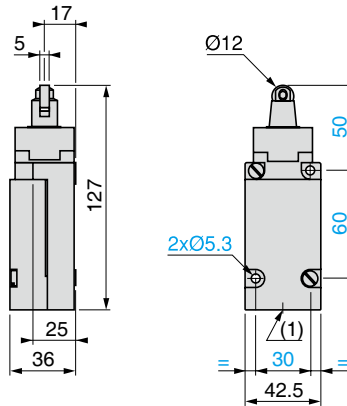

XCK J110511H29, XCK J110513H29

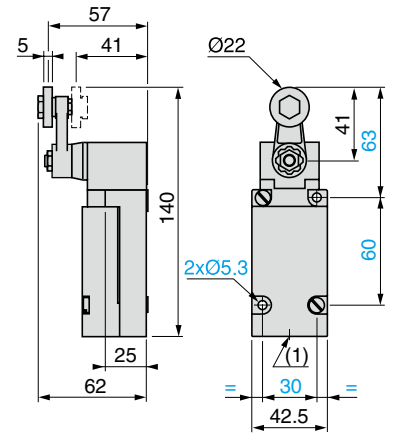

XCK J110541H29

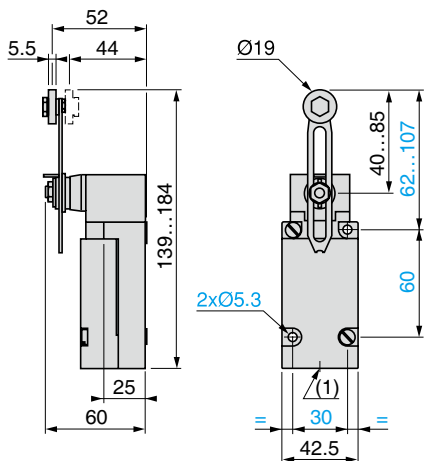

XCK J110559H29

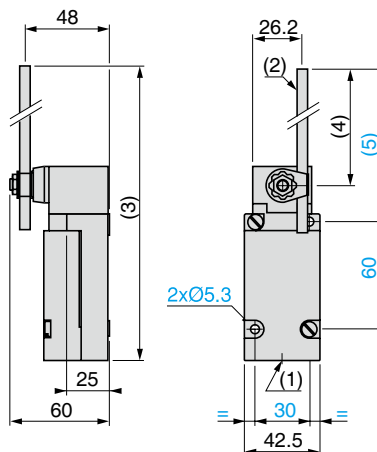









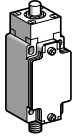
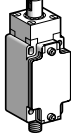
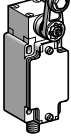
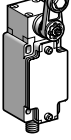

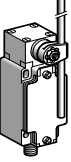

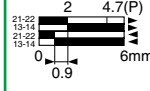
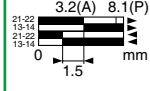
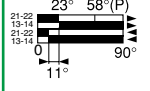
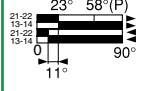
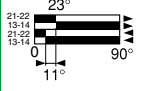
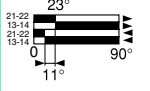
(1) 1 tapped entry for ISO M20 x 1.5 or Pg 13.5 cable gland or for 1/2" NPT conduit.
 (2) Ø 6 rod, length 200 mm.
 (3) 289 max.
 (4) 190 max.
 (5) 212 max.

Limit switches

OsiSense XC Standard, industrial format EN 50041
Metal, conforming to CENELEC EN 50041, type XCK J
Complete switches, fixed body
M12 connector

1

Type of head	Plunger (fixing by the body)		Rotary (fixing by the body) (switches supplied for actuation from left AND right)			
	Form B (1)	Form C (1)	Form A (1)		Form D (1)	
						
Type of operator	Metal end plunger	Steel roller plunger	Thermoplastic roller lever (2)	Steel roller lever (2)	Variable length thermoplastic roller lever (2)	Round thermoplastic rod lever, Ø 6 mm (2) (3)
References (4)						
 2-pole NC + NO snap action (XE2S P2151)	XCK J161D	XCK J167D	XCK J10511D	XCK J10513D	XCK J10541D	XCK J10559D
						
Weight (kg)	0.430	0.455	0.480	0.490	0.485	0.485
Contact operation	 closed  open		(A) = cam displacement (P) = positive opening point			
Characteristics						
Switch actuation	On end	By 30° cam			By any moving part	
Type of actuation						
Maximum actuation speed	0.5 m/s	1 m/s	1.5 m/s			
Mechanical durability (in millions of operating cycles)	30	25	30			
Minimum force or torque	For tripping	20 N	16 N	0.25 N.m		
	For positive opening	50 N	40 N	0.50 N.m		
Connection	M12 connector, U _i = 60 V, I _e = 4 A (see suitable pre-wired female connectors below).					
(1) Form conforming to EN 50041, see page 1/177. (2) Adjustable throughout 360° in 5° steps, or in 45° steps by reversing the lever or its mounting. (3) Value taken with actuation by moving part at 100 mm from the fixing. (4) Switches with gold contacts: please consult our Customer Care Centre.						
References of suitable pre-wired female connectors						
Type of connector	M12 straight, 5-pin, 4 A/24 V max.			M12 elbowed, 5-pin, 4 A/24 V max.		
With cable, Ø 5.8 mm (4 x 0.34 mm ² + 1 x 0.5 mm ²)	L = 2 m	XZ CP1164L2		XZ CP1264L2		
	L = 5 m	XZ CP1164L5		XZ CP1264L5		
	L = 10 m	XZ CP1164L10		XZ CP1264L10		
Weight (kg)	L = 2 m	0.115				
	L = 5 m	0.270				
	L = 10 m	0.520				

Limit switches

OsiSense XC Standard, industrial format EN 50041
Metal, conforming to CENELEC EN 50041, type XCK J
Complete switches, fixed body
M12 connector

Dimensions

XCK J161D

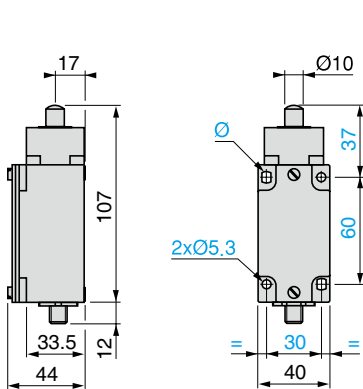

XCK J167D

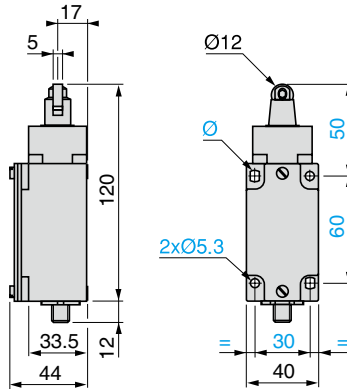

XCK J1051●D

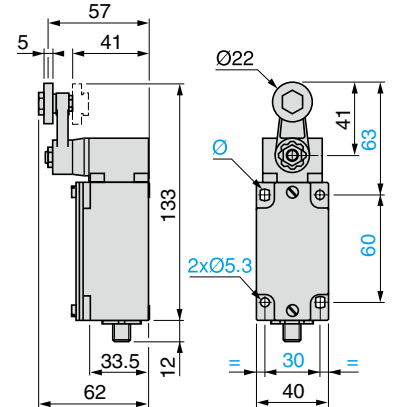

XCK J10541D

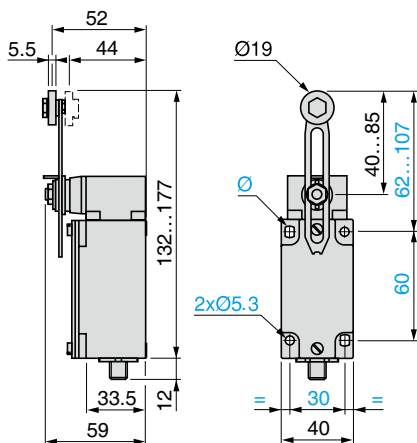

XCK J10559D

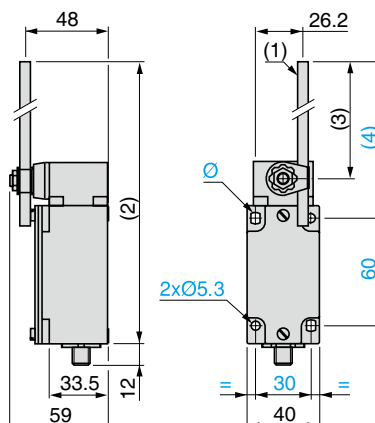

XZ CP1164L●

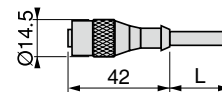

XZ CP1264L●

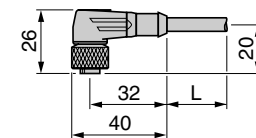

- (1) Ø 6 rod, length 200 mm.
- (2) 282 max.
- (3) 190 max.
- (4) 212 max.
- Ø: 2 elongated holes Ø 5.3 x 7.3.
- L: Cable length 2, 5 or 10 m.

Connections

Limit switch XCK J●●●●D

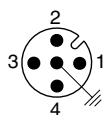

- 1-2 = NC
- 3-4 = NO
- 5 = \perp
- 4 A / 24 V max.

Pre-wired female connector XZ CP1●64L●

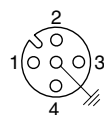







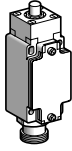
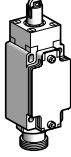
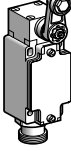
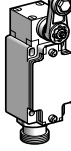

- 1 = brown
- 2 = white
- 3 = blue
- 4 = black
- 5 = \perp yellow/green

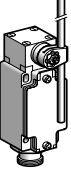

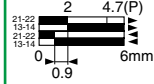
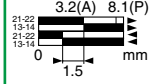
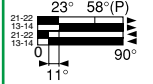
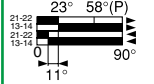
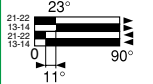
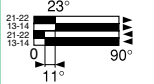

Limit switches

OsiSense XC Standard, industrial format EN 50041
Metal, conforming to CENELEC EN 50041, type XCK J
Complete switches, fixed body
7/8"-16UN connector

1

Type of head	Plunger (fixing by the body)		Rotary (fixing by the body) (switches supplied for actuation from left AND right)			
	Form B (1)	Form C (1)	Form A (1)		Form D (1)	
						
Type of operator	Metal end plunger	Steel roller plunger	Thermoplastic roller lever (2)	Steel roller lever (2)	Variable length thermoplastic roller lever (2)	Round thermoplastic rod lever, Ø 6 mm (2) (3)

References (4)	2-pole NC + NO snap action (XE2S P2151)					
	XCK J161A	XCK J167A	XCK J10511A	XCK J10513A	XCK J10541A	XCK J10559A
						
Weight (kg)	0.430	0.455	0.480	0.490	0.485	0.485
Contact operation	 closed  open		(A) = cam displacement (P) = positive opening point		 NC contact with positive opening operation	

Characteristics		By 30° cam			By any moving part
Switch actuation	On end	By 30° cam		By any moving part	
Type of actuation					
Maximum actuation speed	0.5 m/s	1 m/s	1.5 m/s		
Mechanical durability (in millions of operating cycles)	30	25	30		
Minimum force or torque	For tripping	20 N	16 N	0.25 N.m	
	For positive opening	50 N	40 N	0.50 N.m	
Connection	7/8"-16UN connector, Ui = 250 V; Ie = 6 A (see suitable pre-wired female connectors below).				

- (1) Form conforming to EN 50041, see page 1/177.
- (2) Adjustable throughout 360° in 5° steps, or in 45° steps by reversing the lever or its mounting.
- (3) Value taken with actuation by moving part at 100 mm from the fixing.
- (4) Switches with gold contacts: please consult our Customer Care Centre.

References of suitable pre-wired female connectors		
Type of connector	7/8"-16UN straight, 5-pin, 6 A/250 V max.	
With cable, Ø 6.7 mm (5 x 0.5 mm ²)	L = 2 m	XZ CP1771L2
	L = 5 m	XZ CP1771L5
	L = 10 m	XZ CP1771L10
Weight (kg)	L = 2 m	0.190
	L = 5 m	0.475
	L = 10 m	0.950

Limit switches

OsiSense XC Standard, industrial format EN 50041
Metal, conforming to CENELEC EN 50041, type XCK J
Complete switches, fixed body
7/8"-16UN connector

1

Dimensions

XCK J161A

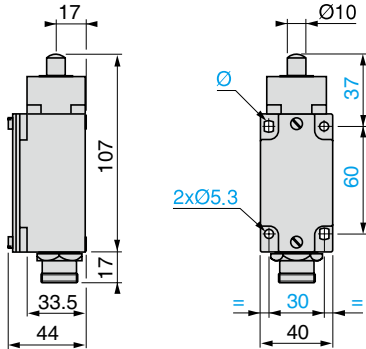

XCK J167A

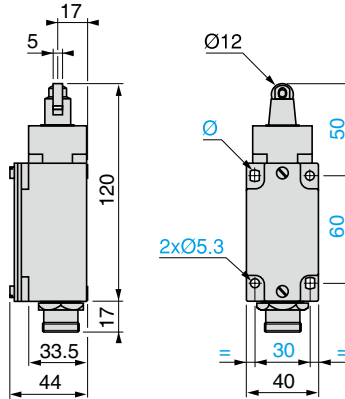

XCK J1051●A

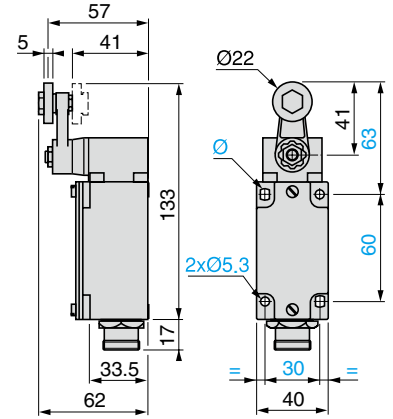

XCK J10541A

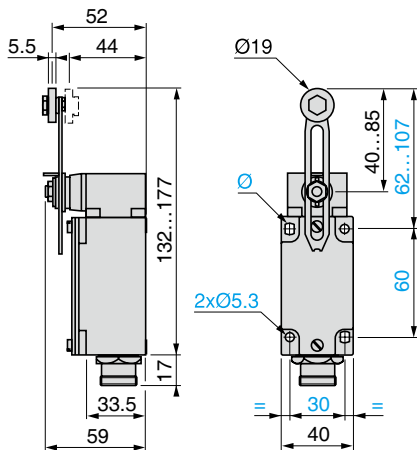

XCK J10559A

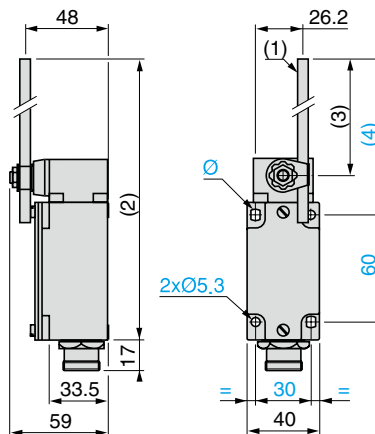

XZ CP1771L●

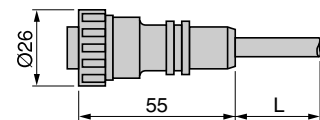

- (1) Ø 6 rod, length 200 mm.
- (2) 282 max.
- (3) 190 max.
- (4) 212 max.
- Ø: 2 elongated holes Ø 5.3 x 7.3.
- L: Cable length 2, 5 or 10 m.

Connections

Limit switch XCK J●●●●A

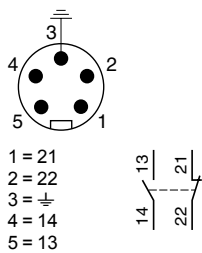

Pre-wired female connector XZ CP1771L●

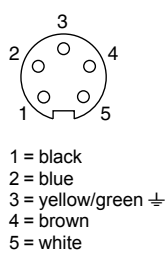

Limit switches

OsiSense XC Standard, industrial format EN 50041
 Metal, conforming to CENELEC EN 50041, type XCK J
 Fixed or plug-in body
 Variable composition: standard bodies

1

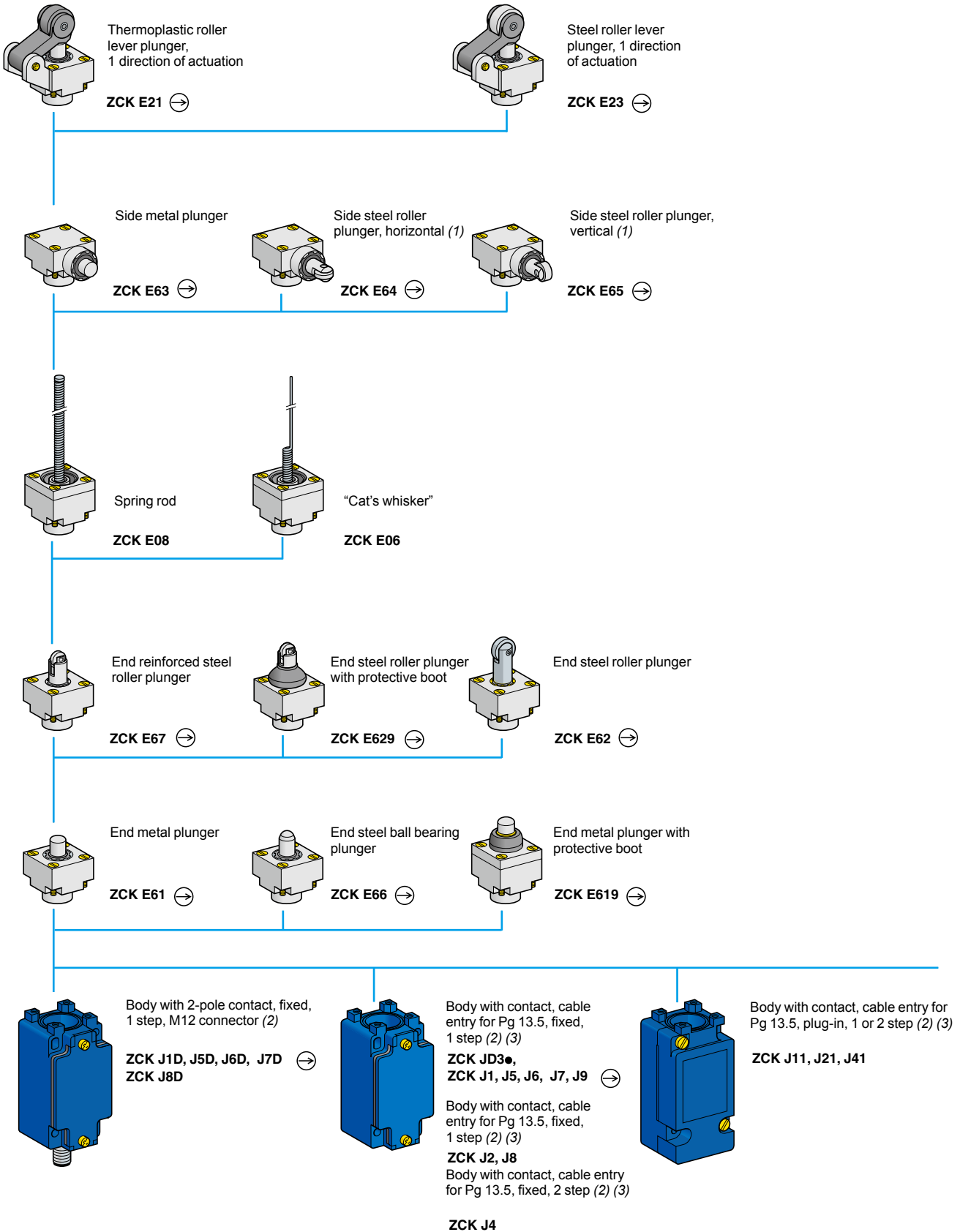

(1) Cannot be used with bodies ZCK J4 and ZCK J41.

(2) For further information, see page 1/112.

(3) For a cable entry tapped ISO M20 x 1.5, add **H29** to the reference. Example: ZCK J1 becomes **ZCK J1H29**.
 For a cable entry tapped 1/2" NPT, add **H7** to the reference. Example: ZCK J1 becomes **ZCK J1H7**.

Limit switches

OsiSense XC Standard, industrial format EN 50041
 Metal, conforming to CENELEC EN 50041, type XCK J
 Fixed or plug-in body
 Variable composition: standard bodies

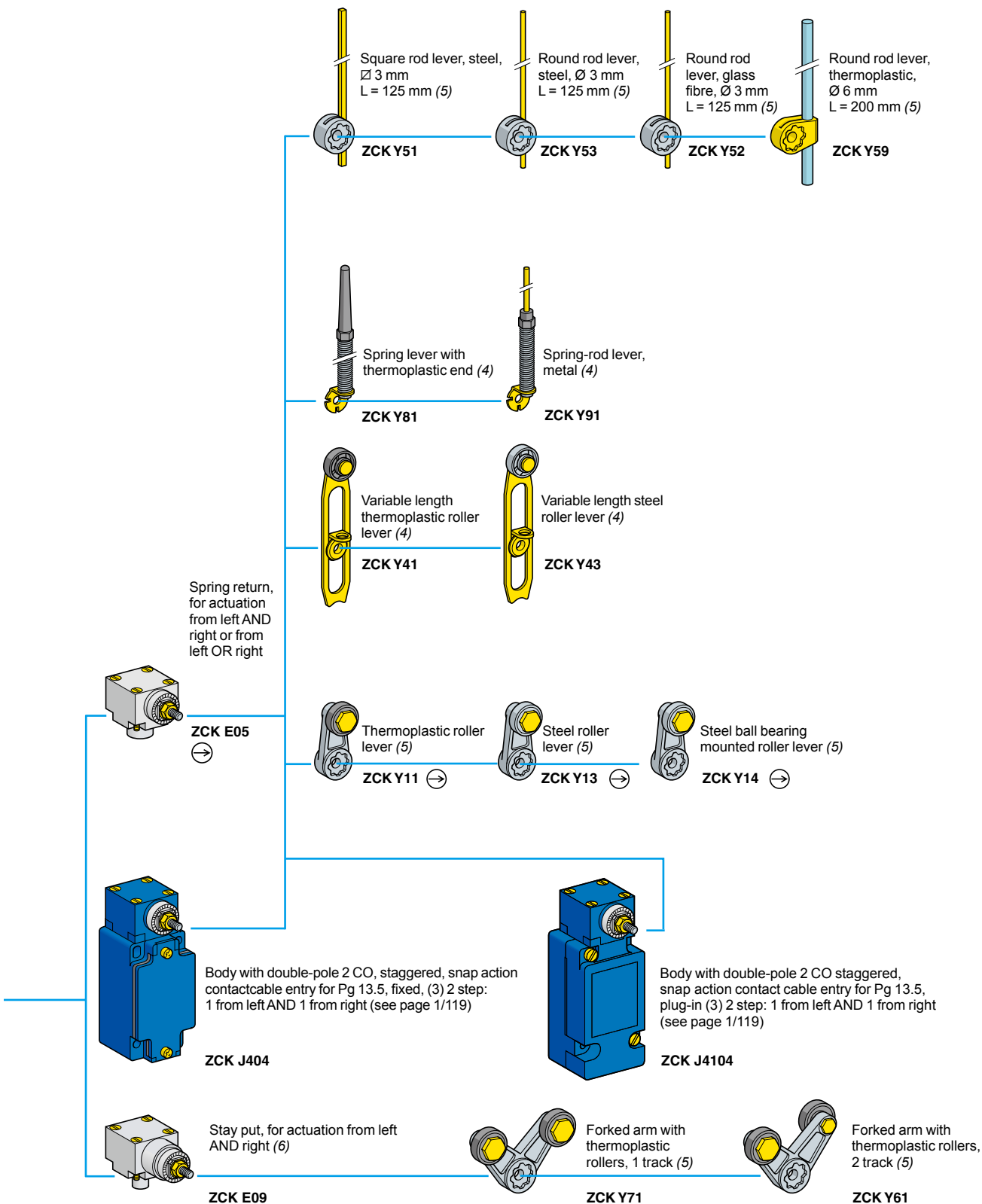

⊖ : head assuring positive opening operation.

(4) Adjustable throughout 360° in 5° steps, or in 90° steps by reversing the notched washer.

(5) Adjustable throughout 360° in 5° steps, or in 45° steps by reversing the lever mounting.

(6) Suitable for bodies with contacts ZCK J1●, J2●, J31, J39.

Limit switches

OsiSense XC Standard, industrial format EN 50041

Metal, conforming to CENELEC EN 50041, type XCK J

Fixed or plug-in body

Adaptable sub-assemblies: standard bodies

1

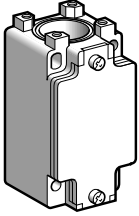

ZCK J●

Fixed bodies with 2-pole contact

Type	With contact block	Scheme	Positive operation (1)	Cable entry	Reference	Weight kg
1 step	NC + NO snap action (XE2S P2151)		⊕	Pg 13.5	ZCK J1	0.310
				ISO M20 x 1.5	ZCK J1H29	0.310
				1/2" NPT	ZCK J1H7	0.310
	2 CO simultaneous, snap action (XES P2021)		-	Pg 13.5	ZCK J2	0.310
				ISO M20 x 1.5	ZCK J2H29	0.310
				1/2" NPT	ZCK J2H7	0.310
	NC + NO break before make, slow break (XE2N P2151)		⊕	Pg 13.5	ZCK J5	0.310
				ISO M20 x 1.5	ZCK J5H29	0.310
				1/2" NPT	ZCK J5H7	0.310
NO + NC make before break, slow break (XE2N P2161)		⊕	Pg 13.5	ZCK J6	0.310	
			ISO M20 x 1.5	ZCK J6H29	0.310	
			1/2" NPT	ZCK J6H7	0.310	
NC + NC simultaneous, slow break (XE2N P2141)		⊕	Pg 13.5	ZCK J7	0.310	
			ISO M20 x 1.5	ZCK J7H29	0.310	
			1/2" NPT	ZCK J7H7	0.310	
NO + NO simultaneous, slow break (XE2N P2131)		-	Pg 13.5	ZCK J8	0.310	
			ISO M20 x 1.5	ZCK J8H29	0.310	
			1/2" NPT	ZCK J8H7	0.310	
NC + NC snap action (XE2S P2141)		⊕	Pg 13.5	ZCK J9	0.310	
			ISO M20 x 1.5	ZCK J9H29	0.310	
			1/2" NPT	ZCK J9H7	0.310	
2 step	2 CO staggered snap action (XES P2031)		-	Pg 13.5	ZCK J4	0.310
				ISO M20 x 1.5	ZCK J4H29	0.310
				1/2" NPT	ZCK J4H7	0.310

Fixed bodies with 3-pole contact

Type	With contact block	Scheme	Positive operation (1)	Cable entry	Reference	Weight kg
-	NC + NO + NO snap action (XE3S P2151)		⊕	Pg 13.5	ZCK JD31	0.310
				ISO M20 x 1.5	ZCK JD31H29	0.310
				1/2" NPT	ZCK JD31H7	0.310
				NC + NC + NO snap action (XE3S P2141)		⊕
ISO M20 x 1.5	ZCK JD39H29	0.310				
1/2" NPT	ZCK JD39H7	0.310				
NC + NC + NO break before make, slow break (XE3N P2141)		⊕	Pg 13.5	ZCK JD37	0.310	
			ISO M20 x 1.5	ZCK JD37H29	0.310	
			1/2" NPT	ZCK JD37H7	0.310	
NC + NO + NO break before make, slow break (XE3N P2151)		⊕	Pg 13.5	ZCK JD35	0.310	
			ISO M20 x 1.5	ZCK JD35H29	0.310	
			1/2" NPT	ZCK JD35H7	0.310	

(1) ⊕: NC contact with positive opening operation.

Limit switches

OsiSense XC Standard, industrial format EN 50041

Metal, conforming to CENELEC EN 50041, type XCK J

Fixed or plug-in body

Adaptable sub-assemblies: standard bodies

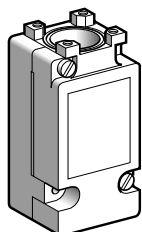

ZCK J1

Plug-in bodies with contact						
Type	With contact block	Scheme	Positive operation (1)	Cable entry	Reference	Weight kg
1 step	Single-pole 1 CO snap action		-	Pg 13.5	ZCK J11	0.300
				ISO M20 x 1.5	ZCK J11H29	0.300
				1/2" NPT	ZCK J11H7	0.300
2 step	Double-pole 2 CO simultaneous, snap action		-	Pg 13.5	ZCK J21	0.300
				ISO M20 x 1.5	ZCK J21H29	0.300
				1/2" NPT	ZCK J21H7	0.300
2 step	Double-pole 2 CO staggered, snap action		-	Pg 13.5	ZCK J41	0.300
				ISO M20 x 1.5	ZCK J41H29	0.300
				1/2" NPT	ZCK J41H7	0.300

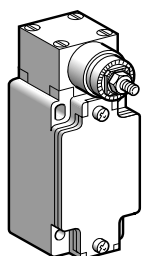

ZCK J404

Bodies with contact, with rotary head (without operating lever)						
Type	With contact block	Scheme	Positive operation (1)	Cable entry	Reference	Weight kg
Fixed body						
2 step 1 from left AND 1 from right (see page 1/119)	Double-pole 2 CO staggered, snap action		-	Pg 13.5	ZCK J404	0.455
				ISO M20 x 1.5	ZCK J404H29	0.455
				1/2" NPT	ZCK J404H7	0.455
Plug-in body						
2 step 1 from left AND 1 from right (see page 1/119)	Double-pole 2 CO staggered, snap action		-	Pg 13.5	ZCK J4104	0.465
				ISO M20 x 1.5	ZCK J4104H29	0.465
				1/2" NPT	ZCK J4104H7	0.465

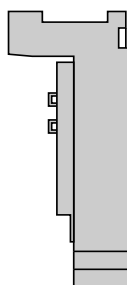

ZCK J0

Plug-in housing only				
Description	For use with	Contacts	Reference	Weight kg
Single-pole 1 CO with positive opening operation	ZCK J11	Silver	ZCK J01	0.150
Double-pole 2 CO with positive opening operation	ZCK J21	Silver	ZCK J02	0.160
Double-pole 1 CO + 1 CO staggered	ZCK J41	Silver	ZCK J04	0.160

(1) ⊖: NC contact with positive opening operation.

Limit switches

OsiSense XC Standard, industrial format EN 50041 Metal, conforming to CENELEC EN 50041, type XCK J Fixed or plug-in body. Adaptable sub-assemblies: bodies with indicator light module

1

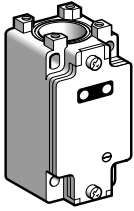

ZCK J...

Fixed bodies with 2-pole contact

Type	With contact block	Scheme	Positive operation (1)	Cable entry	Reference	Weight kg
With module comprising 1 LED, 24 V $\overline{\text{---}}$						
1 step	NC + NO snap action (XE2S P2151)			Pg 13.5	ZCK J120	0.320
	NC + NO break before make, slow break (XE2N P2151)			Pg 13.5	ZCK J520	0.320
With module comprising 2 LEDs, 24 V $\overline{\text{---}}$						
1 step	NC + NO snap action (XE2S P2151)			Pg 13.5 ISO M20 x 1.5	ZCK J121 ZCK J121H29	0.320 0.320
	NC + NO break before make, slow break (XE2N P2151)			Pg 13.5 ISO M20 x 1.5	ZCK J521 ZCK J521H29	0.320 0.320
With module comprising 2 LEDs, 110/240 V \sim						
1 step	NC + NO snap action (XE2S P2151)			Pg 13.5 ISO M20 x 1.5	ZCK J134 ZCK J134H29	0.320 0.320
	NC + NO break before make, slow break (XE2N P2151)			Pg 13.5 ISO M20 x 1.5	ZCK J534 ZCK J534H29	0.320 0.320

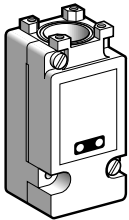

ZCK J1...

Plug-in bodies with single-pole contact

Type	With contact block	Scheme	Positive operation (1)	Cable entry	Reference	Weight kg
With module comprising 2 LEDs, 24 V $\overline{\text{---}}$						
1 step	CO snap action		-	Pg 13.5 ISO M20 x 1.5	ZCK J1121 ZCK J1121H29	0.340 0.340
With module comprising 2 LEDs, 110/240 V \sim						
1 step	CO snap action		-	Pg 13.5 ISO M20 x 1.5	ZCK J1134 ZCK J1134H29	0.340 0.340

(1) : NC contact with positive opening operation.

Indicator light module characteristics

Type of indicator	1 LED or 2 LEDs	2 LEDs
Rated insulation voltage	50 V $\overline{\text{---}}$, conforming to IEC 60947-1	250 V \sim , conforming to IEC 60947-1
Current consumption	7 mA per LED	9 mA per LED
Rated operational voltage	24 V $\overline{\text{---}}$	110/240 V \sim
Voltage limits	20...30 V $\overline{\text{---}}$ (including ripple)	95...264 V \sim
Service life	100 000 hours	100 000 hours
Reverse polarity protection	Yes	-

Limit switches

OsiSense XC Standard, industrial format EN 50041
Metal, conforming to CENELEC EN 50041, type XCK J
Fixed or plug-in body. Adaptable sub-assemblies:
bodies with M12 connector

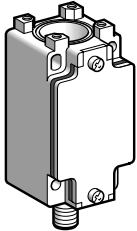

ZCK J•D

Fixed bodies with 2-pole contact					
Type	With contact block	Scheme	Positive operation (1)	Reference	Weight kg
1 step	NC + NO snap action (XE2S P2151)			ZCK J1D	0.320
	NC + NO break before make, slow break (XE2N P2151)			ZCK J5D	0.320
	NO + NC make before break, slow break (XE2N P2161)			ZCK J6D	0.320
	NC + NC simultaneous, slow break (XE2N P2141)			ZCK J7D	0.320
	NO + NO simultaneous, slow break (XE2N P2131)		-	ZCK J8D	0.320

(1) NC contact with positive opening operation.

Limit switches

OsiSense XC Standard, industrial format EN 50041
 Metal, conforming to CENELEC EN 50041, type XCK J
 Fixed or plug-in body
 Adaptable sub-assemblies: contact blocks

1



XE2S P21●1

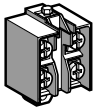

XE2N P21●1

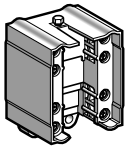

XE3 P20●1

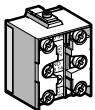

XE3● P21●1

Contact blocks						
Type of contact	Scheme	For bodies	Positive operation (1)	Reference	Weight kg	
2-pole contact						
NC + NO snap action		ZCK J1 ZCK J1D	⊖	XE2S P2151	0.020	
NC + NO break before make, slow break		ZCK J5 ZCK J5D	⊖	XE2N P2151	0.020	
2 CO simultaneous snap action		ZCK J2	-	XES P2021	0.045	
2 CO staggered, snap action		ZCK J4	-	XES P2031	0.045	
NO + NC make before break, slow break		ZCK J6 ZCK J6D	⊖	XE2N P2161	0.020	
NC + NC simultaneous, slow break		ZCK J7 ZCK J7D	⊖	XE2N P2141	0.020	
NO + NO simultaneous, slow break		ZCK J8 ZCK J8D	-	XE2N P2131	0.020	
NC + NC snap action		ZCK J9	⊖	XE2S P2141	0.020	
3-pole contact						
NC + NO + NO snap action		ZCK JD31	⊖	XE3S P2151	0.035	
NC + NC + NO snap action		ZCK JD39	⊖	XE3S P2141	0.035	
NC + NC + NO break before make, slow break		ZCK JD37	⊖	XE3N P2141	0.035	
NC + NO + NO break before make, slow break		ZCK JD35	⊖	XE3N P2151	0.035	

(1) ⊖: NC contact with positive opening operation.

Limit switches

OsiSense XC Standard, industrial format EN 50041

Metal, conforming to CENELEC EN 50041, type XCK J

Fixed or plug-in body

Adaptable sub-assemblies: add-ons

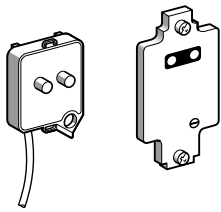

ZCK Z0●●

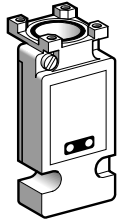

ZCK J01●●

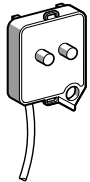

ZCK J90●

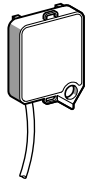

ZCK J82A

Covers + indicator light module

For use with	Number and type of indicators	Voltage	Reference	Weight kg
Fixed body	1 LED	24 V $\overline{\text{---}}$	ZCK Z020	0.060
	2 LEDs	24 V $\overline{\text{---}}$	ZCK Z021	0.060
	2 LEDs	110/240 V \sim	ZCK Z034	0.060
Plug-in body	2 LEDs	24 V $\overline{\text{---}}$	ZCK J0121	0.200
	2 LEDs	110/240 V \sim	ZCK J0134	0.200

Indicator light modules

For use with	Number and type of indicators	Voltage	Reference	Weight kg
Fixed body	1 LED	24 V $\overline{\text{---}}$	ZCK J902	0.030
	2 LEDs	24 V $\overline{\text{---}}$	ZCK J906	0.030
	2 LEDs	110/240 V \sim	ZCK J904	0.030

Module with resistor for machine diagnostics

For use with	Resistor value	Reference	Weight kg
Fixed body (ZCK J1 only)	15 k Ω , 1/4 W	ZCK J82A	0.030

Other versions

Covers + indicator light module for other supply voltages.
Please consult our Customer Care Centre.

Limit switches

OsiSense XC Standard, industrial format EN 50041
 Metal, conforming to CENELEC EN 50041, type XCK J
 Fixed or plug-in body
 Adaptable sub-assemblies

1

Function diagrams (positive operation assured only if the associated sub-assemblies are)

Heads ZCK E61, E619, E66 with body

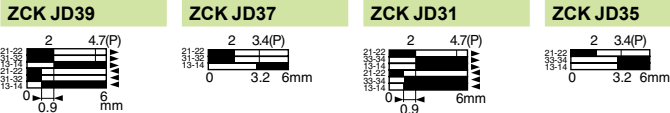
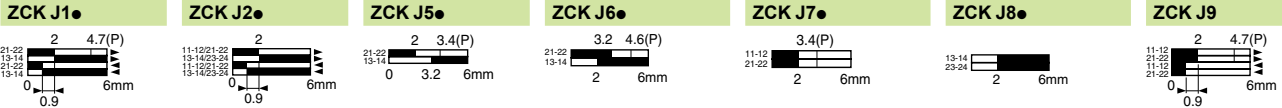

Head ZCK E63 with body

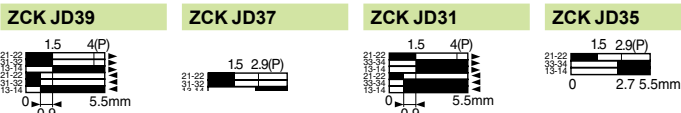
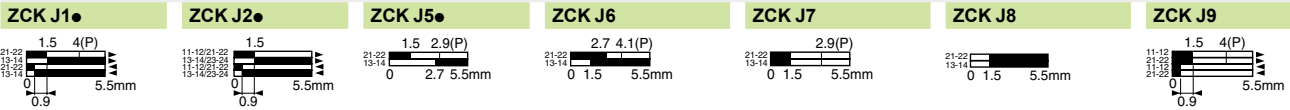

Heads ZCK E64, E65 with body

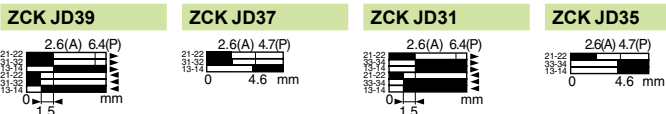
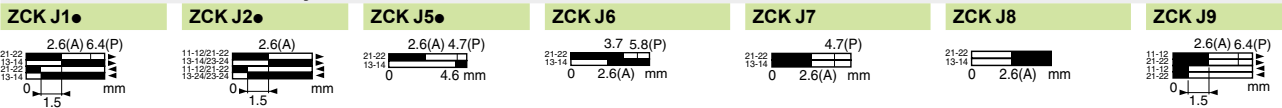

Heads ZCK E67, E629 with body

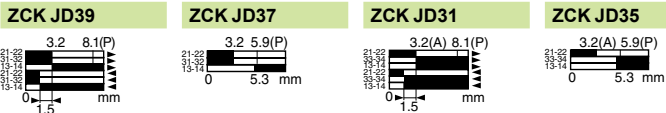
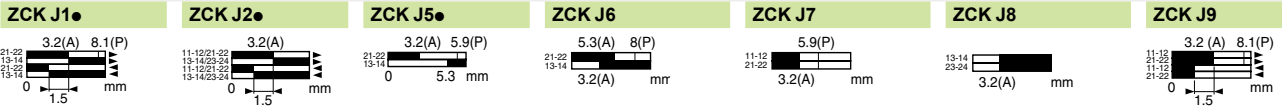

Heads ZCK E21, E23 with body

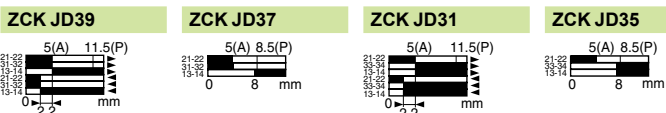
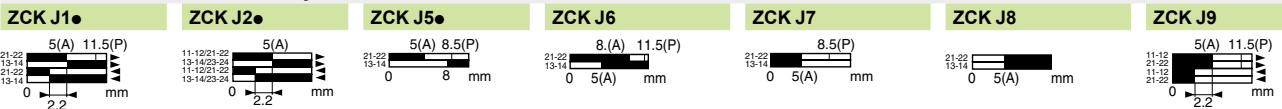

Heads ZCK E06, E08 with body

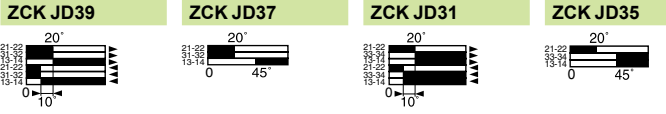
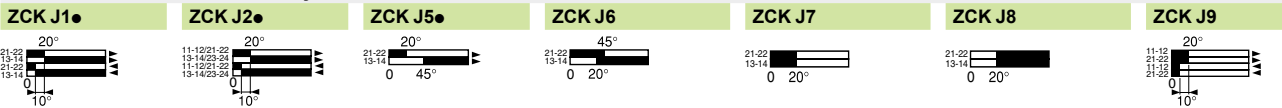

ZCK J4

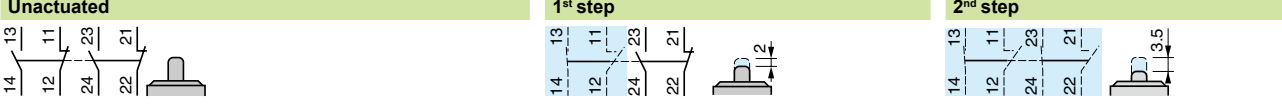

Contact operation closed open (A) = cam displacement (P) = positive opening point

Limit switches

OsiSense XC Standard, industrial format EN 50041
Metal, conforming to CENELEC EN 50041, type XCK J
Fixed or plug-in body
Adaptable sub-assemblies

Function diagrams (positive operation assured only if the associated sub-assemblies are)

Head ZCK E05 with body

ZCK J1●

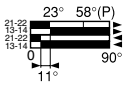

ZCK J2●

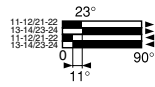

ZCK J5●

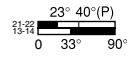

ZCK J6

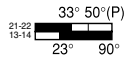

ZCK J7

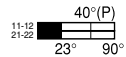

ZCK J8



ZCK J9

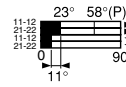

ZCK JD39

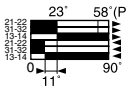

ZCK JD37

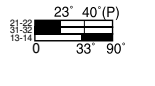

ZCK JD39

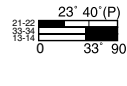

ZCK JD31

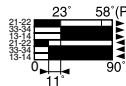

ZCK J4●

Unactuated

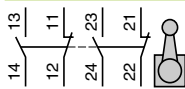

1st step, actuated from left or right

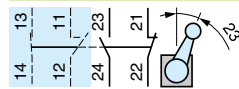

2nd step, actuated from left or right

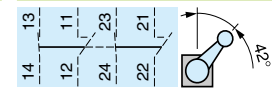

Head ZCK E09 with body

ZCK J1●

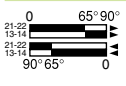

ZCK J2●

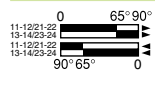

ZCK JD31

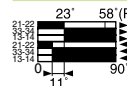

ZCK JD39

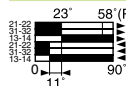

ZCK J404, J4104 (body with head)

Unactuated

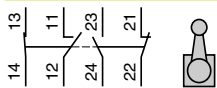

Actuated from left

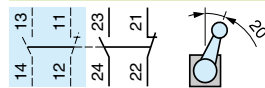

Actuated from right

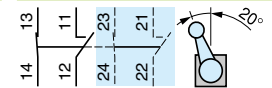

Contact operation

closed
 open

(P) = positive opening point

Wiring schemes

Indicator light

1 LED, 24 V ...

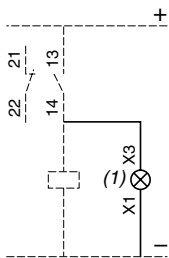

2 LEDs, 24 V ...

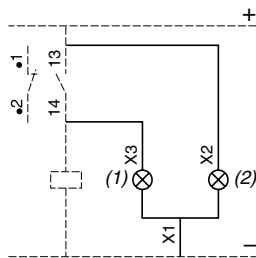

Module with resistor

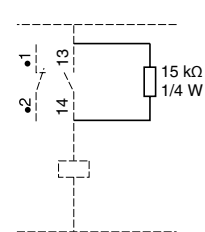

(1) Orange indicator
(2) Green indicator

ZCK J●D

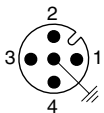

1 - 2 = NC
3 - 4 = NO
5 = \perp
4 A / 24 V max.



Limit switches

OsiSense XC Standard, industrial format EN 50041
 Metal, conforming to CENELEC EN 50041, type XCK J
 Fixed or plug-in body
 Adaptable sub-assemblies

1

Bodies

ZCK J1, J2, J5, J4, J \bullet 2 \bullet , J \bullet 3 \bullet , J6, J7, J8, J9
 ZCK J1H29, J2H29, J5H29, J4H29, J \bullet 2 \bullet H29, J \bullet 3 \bullet H29,
 J6H29, J7H29, J8H29, J9H29
 ZCK J1H7, J2H7, J5H7, J4H7, J \bullet 2 \bullet H7, J \bullet 3 \bullet H7, J6H7,
 J7H7, J8H7, J9H7

ZCK J11, J21, J41, J11 $\bullet\bullet$
 ZCK J11H29, J21H29, J41H29, J11 $\bullet\bullet$ H29
 ZCK J11H7, J21H7, J41H7, J11 $\bullet\bullet$ H7

ZCK J1D, J5D, J6D, J7D, J8D

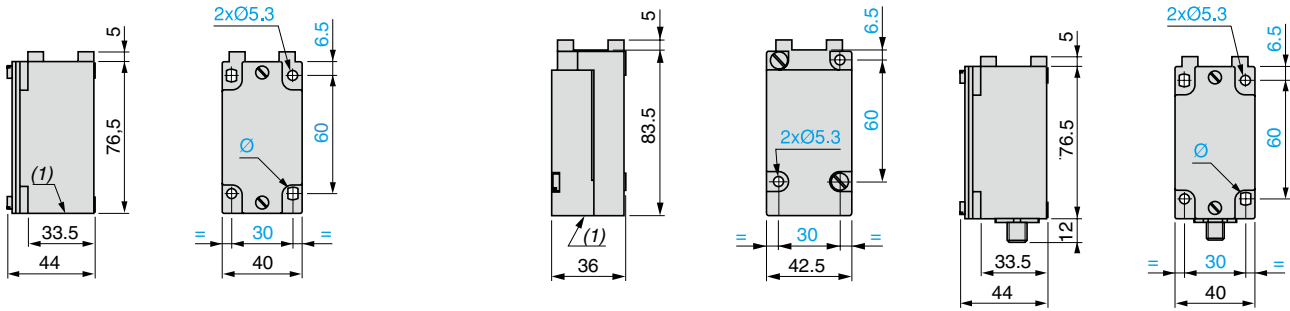

Bodies with rotary head mounted

ZCK J404, ZCK J404H29, ZCK J404H7

ZCK J4104, ZCK J4104H29, ZCK J4104H7

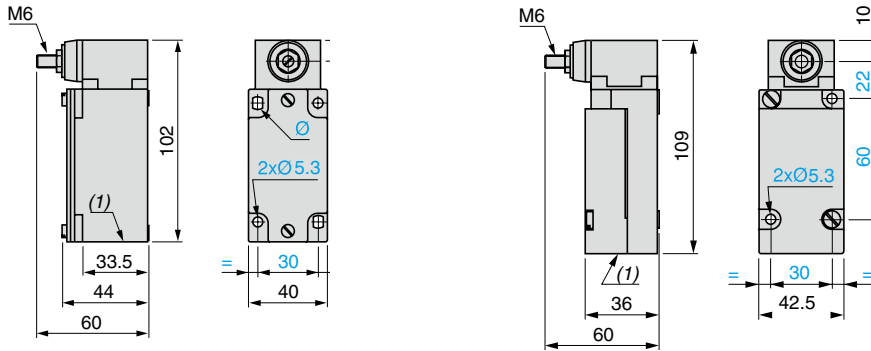

Plunger heads

ZCK E61

ZCK E619

ZCK E63

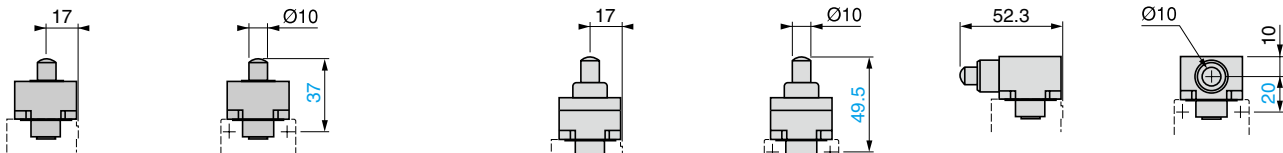

ZCK E64

ZCK E65

ZCK E66

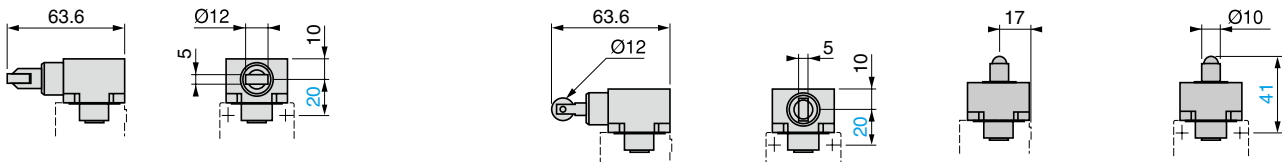

ZCK E62, ZCK E67

ZCK E629

ZCK E21, E23

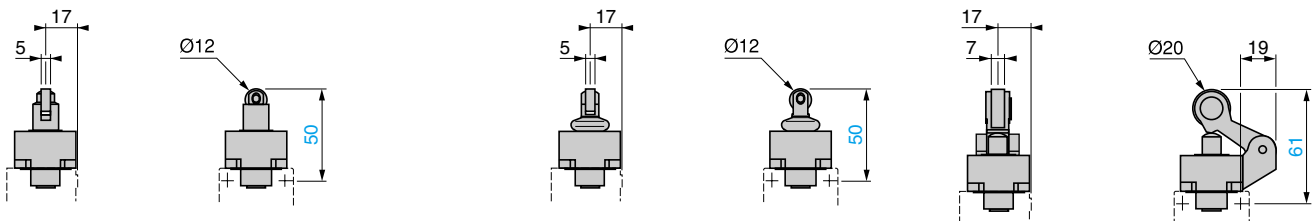

(1) 1 tapped entry for ISO M20 x 1.5 or Pg 13.5 cable gland or tapped 1/2" NPT.
 Ø: 2 elongated holes Ø 5.3 x 7.3.

Limit switches

OsiSense XC Standard, industrial format EN 50041
 Metal, conforming to CENELEC EN 50041, type XCK J
 Fixed or plug-in body
 Adaptable sub-assemblies



Rotary head ZCK E05 with operating lever

ZCK Y11, Y13, Y14

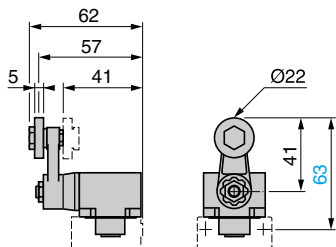

ZCK Y41, Y43

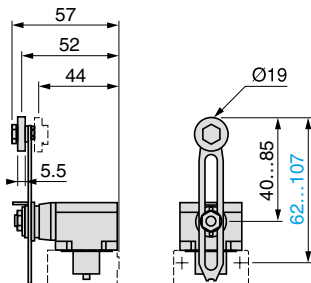

ZCK Y51, Y52, Y53, Y59

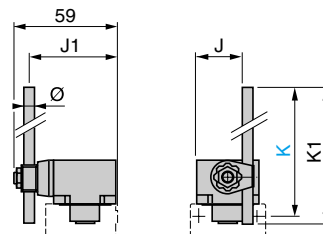

	J	J1	K max.	K1	Ø
ZCK Y51	20	49	137	123	∅ 3
ZCK Y52	20	49	137	125	∅ 3
ZCK Y53	20	49	137	125	∅ 3
ZCK Y59	26.2	48	212	200	∅ 6

ZCK Y81

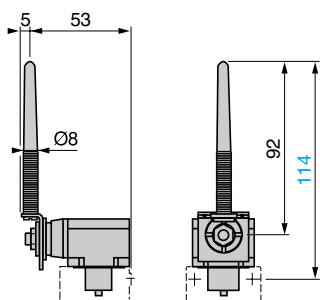

ZCK Y91

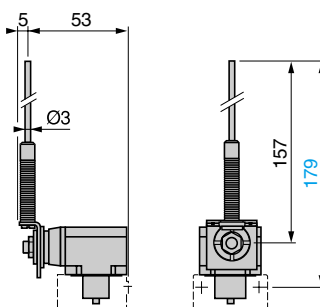

Rotary head ZCK E09 with operating lever

ZCK Y61

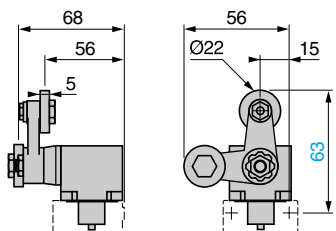

ZCK Y71

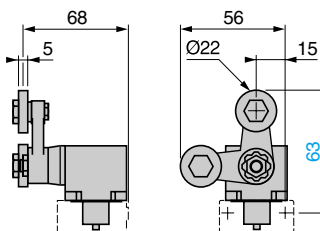

Multi-directional heads

ZCK E06

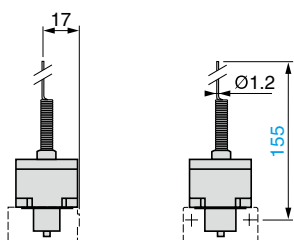

ZCK E08

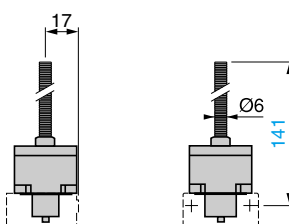

Note: operating lever spindle threaded M6.

Limit switches

OsiSense XC Standard, industrial format EN 50041
 Metal, conforming to CENELEC EN 50041, type XCK J
 Fixed or plug-in body
 Adaptable sub-assemblies for low temperature applications (- 40°C)

1

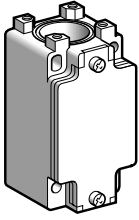

ZCK J1

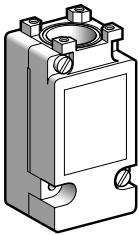

ZCK J11

Bodies with contacts		For plunger or rotary head				
Type	With contact block	Scheme	Positive operation (1)	Cable entry	Reference	Weight kg
Fixed bodies						
1 step	2-pole NC + NO snap action (XE2S P2151)		⊕	Pg 13.5	ZCK J1	0.310
				ISO M20 x 1.5	ZCK J1H29	0.310
				1/2" NPT	ZCK J1H7	0.310
	Double-pole 2 CO simultaneous, snap action (XES P2021)		-	Pg 13.5	ZCK J2	0.310
				ISO M20 x 1.5	ZCK J2H29	0.310
				1/2" NPT	ZCK J2H7	0.310
	2-pole NC + NO break before make, slow break (XE2N P2151)		⊕	Pg 13.5	ZCK J5	0.310
ISO M20 x 1.5				ZCK J5H29	0.310	
1/2" NPT				ZCK J5H7	0.310	
2-pole NO + NC make before break, slow break (XE2N P2161)		⊖	Pg 13.5	ZCK J6	0.310	
			ISO M20 x 1.5	ZCK J6H29	0.310	
			1/2" NPT	ZCK J6H7	0.310	
2-pole NC + NC simultaneous, slow break (XE2N P2141)		⊖	Pg 13.5	ZCK J7	0.310	
			ISO M20 x 1.5	ZCK J7H29	0.310	
			1/2" NPT	ZCK J7H7	0.310	
2-pole NO + NO simultaneous, slow break (XE2N P2131)		-	Pg 13.5	ZCK J8	0.310	
			ISO M20 x 1.5	ZCK J8H29	0.310	
			1/2" NPT	ZCK J8H7	0.310	
2-pole NC + NC snap action (XE2S P2141)		⊖	Pg 13.5	ZCK J9	0.310	
			ISO M20 x 1.5	ZCK J9H29	0.310	
			1/2" NPT	ZCK J9H7	0.310	
2 step	Double-pole 2 CO staggered, snap action (XES P2031)		-	Pg 13.5	ZCK J4	0.310
				ISO M20 x 1.5	ZCK J4H29	0.310
				1/2" NPT	ZCK J4H7	0.310
Plug-in bodies						
1 step	Single-pole CO snap action		-	Pg 13.5	ZCK J11	0.300
				ISO M20 x 1.5	ZCK J11H29	0.300
				1/2" NPT	ZCK J11H7	0.300
	Double-pole 2 CO simultaneous snap action		-	Pg 13.5	ZCK J21	0.300
				ISO M20 x 1.5	ZCK J21H29	0.300
				1/2" NPT	ZCK J21H7	0.300
2 step	Double-pole 2 CO staggered, snap action		-	Pg 13.5	ZCK J41	0.300
				ISO M20 x 1.5	ZCK J41H29	0.300
				1/2" NPT	ZCK J41H7	0.300

Bodies with contacts		With spring return rotary head (without operating lever)				
Type	With contact block	Scheme	Positive operation (1)	Cable entry	Reference	Weight kg
Fixed body						
2 step 1 from the left AND 1 from the right	Double-pole 2 CO staggered, snap action		-	Pg 13.5	ZCK J4046	0.455
				ISO M20 x 1.5	ZCK J4046H29	0.455
				1/2" NPT	ZCK J4046H7	0.455
Plug-in body						
2 step 1 from the left AND 1 from the right	Double-pole 2 CO staggered, snap action		-	Pg 13.5	ZCK J41046	0.465
				ISO M20 x 1.5	ZCK J41046H29	0.465
				1/2" NPT	ZCK J41046H7	0.465

(1) ⊕: head assuring positive opening operation.

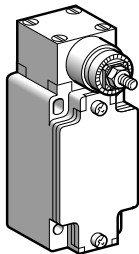

ZCK J4046

Limit switches

OsiSense XC Standard, industrial format EN 50041
 Metal, conforming to CENELEC EN 50041, type XCK J
 Fixed or plug-in body
 Adaptable sub-assemblies for low temperature applications (- 40°C)

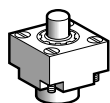

ZCK E616

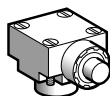

ZCK E636

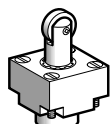

ZCK E626

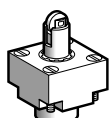

ZCK E676

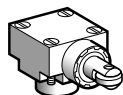

ZCK E646

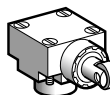

ZCK E656

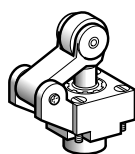

ZCK E216

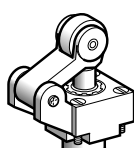

ZCK E236

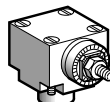

ZCK E056

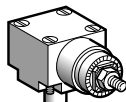

ZCK E096

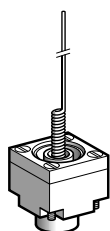

ZCK E066

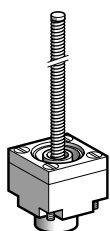

ZCK E086

Plunger heads

Type of operator	Compatible bodies	Maximum actuation speed	Positive operation (1)	Reference	Weight kg	
For actuation on end						
End plunger metal	ZCK J●, ZCK J●●	0.5 m/s	⊕	ZCK E616	0.140	
Side plunger metal	ZCK J●, ZCK J●●, except ZCK J4 and J41	0.5 m/s	⊕	ZCK E636	0.200	
For actuation by 30° cam						
Roller plunger steel	ZCK J●, ZCK J●●	1 m/s	⊕	ZCK E626	0.155	
End reinforced roller plunger steel	ZCK J●, ZCK J●●	1 m/s	⊕	ZCK E676	0.155	
Side roller plunger steel	Horizontal	ZCK J●, ZCK J●●, except ZCK J4 and J41	0.6 m/s	⊕	ZCK E646	0.205
	Vertical	ZCK J●, ZCK J●●, except ZCK J4 and J41	0.6 m/s	⊕	ZCK E656	0.205
Roller lever plunger (1 direction of actuation)	Thermoplastic	ZCK J●, ZCK J●●	1.5 m/s	⊕	ZCK E216	0.185
	Steel	ZCK J●, ZCK J●●	1.5 m/s	⊕	ZCK E236	0.195

Rotary heads (without operating lever)

Type	Compatible bodies	Maximum actuation speed	Positive operation (1)	Reference	Weight kg
Spring return, for actuation from left AND right or from left OR right (see page 1/176)	ZCK J●, ZCK J●●	1.5 m/s by 30° cam	⊕	ZCK E056	0.165
Stay put, for actuation from left AND right (see page 1/176)	ZCK J1, J11 ZCK J2, J21	0.5 m/s	–	ZCK E096	0.190

Multi-directional heads

Type of operator	Compatible bodies	Maximum actuation speed	Positive operation (1)	Reference	Weight kg
For actuation by any moving part					
“Cat’s whisker”	ZCK J●, ZCK J●●, except ZCK J4 and ZCK J41	1 m/s in any direction	–	ZCK E066	0.115
Spring rod	ZCK J●, ZCK J●●, except ZCK J4 and ZCK J41	0.5 m/s in any direction	–	ZCK E086	0.125

(1) ⊕: head assuring positive opening operation.

Limit switches

OsiSense XC Standard, industrial format EN 50041
 Metal, conforming to CENELEC EN 50041, type XCK J
 Fixed or plug-in body
 Adaptable sub-assemblies for low temperature applications (- 40°C)

1



ZCK Y1

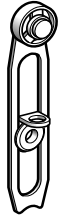

ZCK Y4

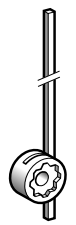

ZCK Y51

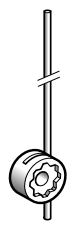

ZCK Y5

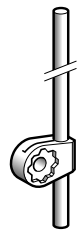

ZCK Y59

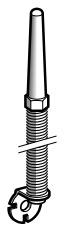

ZCK Y81

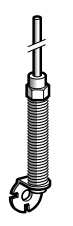

ZCK Y91

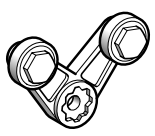

ZCK Y71



ZCK Y61

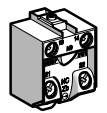

XE2S P21

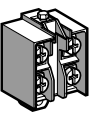

XE2N P21

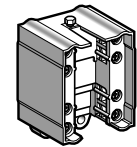

XES P20

Operating levers for rotary heads

Description		Positive operation (1)	Reference	Weight kg
For actuation by 30° cam				
Roller lever (2)	Thermoplastic	⊕	ZCK Y11	0.025
	Steel	⊕	ZCK Y13	0.035
	Steel, ball bearing mounted	⊕	ZCK Y14	0.030
Variable length roller lever (3)	Thermoplastic	-	ZCK Y41	0.030
	Steel	-	ZCK Y43	0.040
For actuation by any moving part				
Square rod (2)	∅ 3 mm steel, L = 125 mm	-	ZCK Y51	0.025
Round rod (2)	∅ 3 mm steel, L = 125 mm	-	ZCK Y53	0.025
	∅ 3 mm glass fibre, L = 125 mm	-	ZCK Y52	0.020
	∅ 6 mm thermoplastic, L = 200 mm	-	ZCK Y59	0.030
Spring lever (3)		-	ZCK Y81	0.020
Spring-metal rod lever (3)		-	ZCK Y91	0.025

For actuation by specific cam (only for operation with head ZCK E096)				
Forked arm with rollers (2)	1 track	-	ZCK Y71	0.035
	2 track	-	ZCK Y61	0.035

2-pole and double-pole contact blocks

Type of contact	Scheme	For body	Positive operation (1)	Reference	Weight kg
NC + NO snap action		ZCK J1	⊕	XE2S P2151	0.020
NC + NO break before make, slow break		ZCK J5	⊕	XE2N P2151	0.020
2 CO simultaneous, snap action		ZCK J2	-	XES P2021	0.045
2 CO staggered, snap action		ZCK J4	-	XES P2031	0.045
NC + NO make before break, slow break		ZCK J6	⊕	XE2N P2161	0.020
NC + NC simultaneous, slow break		ZCK J7	⊕	XE2N P2141	0.020
NO + NO simultaneous, slow break		ZCK J8	-	XE2N P2131	0.020
NC + NC snap action		ZCK J9	⊕	XE2S P2141	0.020

(1) ⊕: NC contact with positive opening operation or sub-assembly assuring positive opening operation.
 (2) Adjustable throughout 360° in 5° steps, or in 45° steps by reversing the lever or its mounting.
 (3) Adjustable throughout 360° in 5° steps.

Limit switches

OsiSense XC Standard, industrial format EN 50041

Metal, conforming to CENELEC EN 50041, type XCK J

Fixed or plug-in body

Adaptable sub-assemblies for high temperature applications (+ 120°C)

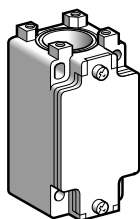

ZCK J6

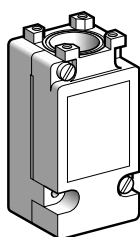

ZCK J15

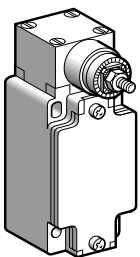

ZCK J4045

Bodies with contacts For plunger or rotary head						
Type	With contact block	Scheme	Positive operation (1)	Cable entry	Reference	Weight kg
Fixed bodies						
1 step	2-pole NC + NO snap action (XE2S P2151)		⊕	Pg 13.5	ZCK J1	0.310
				ISO M20 x 1.5	ZCK J1H29	0.310
				1/2" NPT	ZCK J1H7	0.310
	Double-pole 2 CO simultaneous, snap action (XES P20215)		-	Pg 13.5	ZCK J25	0.310
				ISO M20 x 1.5	ZCK J25H29	0.310
				1/2" NPT	ZCK J25H7	0.310
	2-pole NC + NO break before make, slow break (XE2N P2151)		⊕	Pg 13.5	ZCK J5	0.310
				ISO M20 x 1.5	ZCK J5H29	0.310
				1/2" NPT	ZCK J5H7	0.310
	2-pole NO + NC make before break, slow break (XE2N P2161)		⊕	Pg 13.5	ZCK J6	0.310
ISO M20 x 1.5				ZCK J6H29	0.310	
1/2" NPT				ZCK J6H7	0.310	
2-pole NC + NC simultaneous, slow break (XE2N P2141)		⊕	Pg 13.5	ZCK J7	0.310	
			ISO M20 x 1.5	ZCK J7H29	0.310	
			1/2" NPT	ZCK J7H7	0.310	
2-pole NO + NO simultaneous, slow break (XE2N P2131)		-	Pg 13.5	ZCK J8	0.310	
			ISO M20 x 1.5	ZCK J8H29	0.310	
			1/2" NPT	ZCK J8H7	0.310	
2-pole NC + NC snap action (XE2S P2141)		⊕	Pg 13.5	ZCK J9	0.310	
			ISO M20 x 1.5	ZCK J9H29	0.310	
			1/2" NPT	ZCK J9H7	0.310	
2 step	Double-pole 2 CO staggered, snap action (XES P20315)		-	Pg 13.5	ZCK J45	0.310
				ISO M20 x 1.5	ZCK J45H29	0.310
				1/2" NPT	ZCK J45H7	0.310
Plug-in bodies						
1 step	Single-pole CO snap action		-	Pg 13.5	ZCK J115	0.300
				ISO M20 x 1.5	ZCK J115H29	0.300
				1/2" NPT	ZCK J115H7	0.300
	Double-pole 2 CO simultaneous, snap action		-	Pg 13.5	ZCK J215	0.300
				ISO M20 x 1.5	ZCK J215H29	0.300
				1/2" NPT	ZCK J215H7	0.300
2 step	Double-pole 2 CO staggered, snap action		-	Pg 13.5	ZCK J415	0.300
				ISO M20 x 1.5	ZCK J415H29	0.300
				1/2" NPT	ZCK J415H7	0.300

Bodies with contacts With spring return rotary head (without operating lever)

Type	With contact block	Scheme	Positive operation (1)	Cable entry	Reference	Weight kg
Fixed body						
2 step 1 from the left AND 1 from the right	Double-pole 2 CO staggered, snap action		-	Pg 13.5	ZCK J4045	0.455
				ISO M20 x 1.5	ZCK J4045H29	0.455
				1/2" NPT	ZCK J4045H7	0.455
Plug-in body						
2 step 1 from the left AND 1 from the right	Double-pole 2 CO staggered, snap action		-	Pg 13.5	ZCK J41045	0.465
				ISO M20 x 1.5	ZCK J41045H29	0.465
				1/2" NPT	ZCK J41045H7	0.465

(1) ⊕: head assuring positive opening operation.

Limit switches

OsiSense XC Standard, industrial format EN 50041
 Metal, conforming to CENELEC EN 50041, type XCK J
 Fixed or plug-in body
 Adaptable sub-assemblies for high temperature applications (+ 120°C)

1

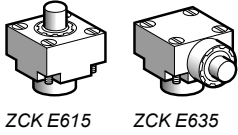

ZCK E615 ZCK E635

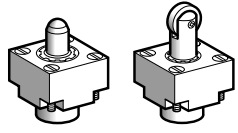

ZCK E665 ZCK E625

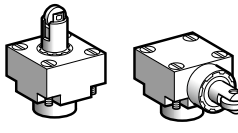

ZCK E675 ZCK E645

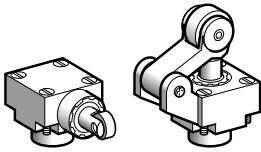

ZCK E655 ZCK E235

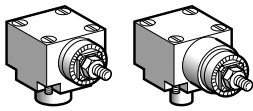

ZCK E055 ZCK E095

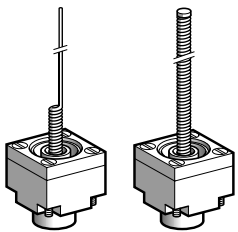

ZCK E065 ZCK E085

Plunger heads

Type of operator	Compatible bodies	Maximum actuation speed	Positive operation (1)	Reference	Weight kg
For actuation on end					
End plunger	Metal	ZCK J1, J2, J4, ZCK J115, J215, J415, ZCK J5, J6, J7, J8, J9	0.5 m/s	⊕	ZCK E615 0.140
Side plunger	Metal	ZCK J1, J2, ZCK J115, J215, ZCK J5, J6, J7, J8, J9	0.5 m/s	⊕	ZCK E635 0.200
For actuation by 30° cam					
End ball bearing plunger	Steel	ZCK J1, J2, J4, ZCK J115, J215, J415, ZCK J5, J6, J7, J8, J9	0.1 m/s	⊕	ZCK E665 0.150
End roller plunger	Steel	ZCK J1, J2, J4, ZCK J115, J215, J415, ZCK J5, J6, J7, J8, J9	1 m/s	⊕	ZCK E625 0.155
End reinforced roller plunger	Steel	ZCK J1, J2, J4, ZCK J115, J215, J415, ZCK J5, J6, J7, J8, J9	1 m/s	⊕	ZCK E675 0.155
Side roller plunger	Steel Horizontal	ZCK J1, J2, ZCK J115, J215, ZCK J5, J6, J7, J8, J9	0.6 m/s	⊕	ZCK E645 0.205
	Steel Vertical	ZCK J1, J2, ZCK J115, J215, ZCK J5, J6, J7, J8, J9	0.6 m/s	⊕	ZCK E655 0.205
Roller lever plunger (1 direction of actuation)	Steel	ZCK J1, J2, J4, ZCK J115, J215, J415, ZCK J5, J6, J7, J8, J9	1.5 m/s	⊕	ZCK E235 0.195
	Thermoplastic	ZCK J1, J2, J4, ZCK J115, J215, J415, ZCK J5, J6, J7, J8, J9	1.5 m/s	⊕	ZCK E215 0.185

Rotary heads (without operating lever)

Type	Compatible bodies	Maximum actuation speed	Positive operation (1)	Reference	Weight kg
Spring return, for actuation from left AND right or from left OR right (see page 1/176)	ZCK J1, J2, J4, ZCK J115, J215, ZCK J415, ZCK J5, J6, J7, J8, J9	1.5 m/s by 30° cam	⊕	ZCK E055	0.165
Stay put, actuation from left AND right (see page 1/176)	ZCK J1, J2, ZCK J115, J215	0.5 m/s	–	ZCK E095	0.190

Multi-directional heads

Type of operator	Compatible bodies	Maximum actuation speed	Positive operation (1)	Reference	Weight kg
For actuation by any moving part					
“Cat’s whisker”	ZCK J1, J2, ZCK J115, J215, ZCK J5, J6, J7, J8, J9	1 m/s in any direction	–	ZCK E065	0.115
Spring rod	ZCK J1, J2, ZCK J115, J215, ZCK J5, J6, J7, J8, J9	0.5 m/s in any direction	–	ZCK E085	0.125

(1) ⊕: head assuring positive opening operation.

Limit switches

OsiSense XC Standard, industrial format EN 50041
Metal, conforming to CENELEC EN 50041, type XCK J
Fixed or plug-in body
Adaptable sub-assemblies for high temperature applications (+ 120°C)



ZCK Y1●

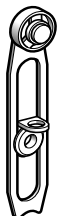

ZCK Y43



ZCK Y51

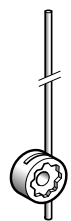

ZCK Y5●

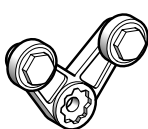

ZCK Y715



ZCK Y615



XE2S P21●1

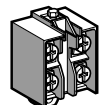

XE2N P21●1

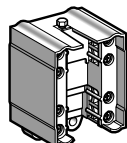

XES P20●15

Operating levers for rotary heads

Description		Positive operation (1)	Reference	Weight kg
For actuation by 30° cam				
Roller lever (2)	Thermoplastic	⊕	ZCK Y115	0.025
	Steel	⊕	ZCK Y13	0.035
	Steel, ball bearing mounted	⊕	ZCK Y14	0.030
Variable length roller lever (3)	Thermoplastic	–	ZCK Y415	0.030
	Steel	–	ZCK Y43	0.040
For actuation by any moving part				
Square rod (2)	∅ 3 mm steel, L = 125 mm	–	ZCK Y51	0.025
Round rod (2)	∅ 3 mm steel, L = 125 mm	–	ZCK Y53	0.025
	∅ 3 mm glass fibre, L = 125 mm	–	ZCK Y52	0.020
For actuation by specific cam (only for operation with head ZCK E095)				
Forked arm with rollers (2)	1 track	–	ZCK Y715	0.035
	2 track	–	ZCK Y615	0.035

2-pole and double-pole contact blocks

Type of contact	Scheme	For bodies	Positive operation (1)	Reference	Weight kg
NC + NO snap action		ZCK J1	⊕	XE2S P2151	0.020
NC + NO break before make, slow break		ZCK J5	⊖	XE2N P2151	0.020
2 CO simultaneous, snap action		ZCK J25	–	XES P20215	0.045
2 CO staggered, snap action		ZCK J45	–	XES P20315	0.045
NC + NO make before break, slow break		ZCK J6	⊖	XE2N P2161	0.020
NC + NC simultaneous, slow break		ZCK J7	⊖	XE2N P2141	0.020
NO + NO simultaneous, slow break		ZCK J8	–	XE2N P2131	0.020
NC + NC snap action		ZCK J9	⊕	XE2S P2141	0.020

(1) ⊕: NC contact with positive opening operation or sub-assembly assuring positive opening operation.

(2) Adjustable throughout 360° in 5° steps, or in 45° steps by reversing the lever or its mounting.

(3) Adjustable throughout 360° in 5° steps.