

8	7	6
HARTING Art.-Nr. / HARTING-art-no	Logo / Label	Länge / Length [mm]
08 968 /020001 A000	HARTING	700
08 968 /020101 A000	customer branding *	700

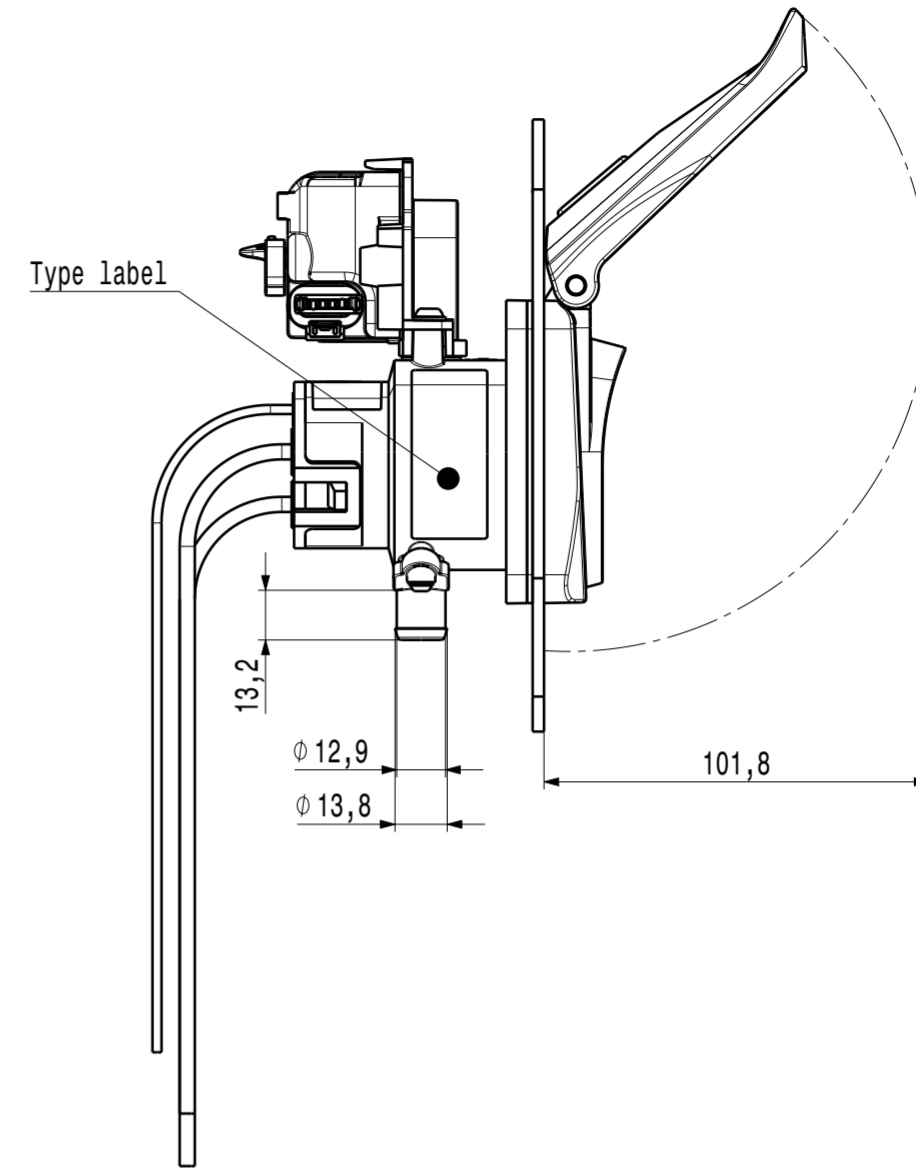

panel cutout  
M 1:1

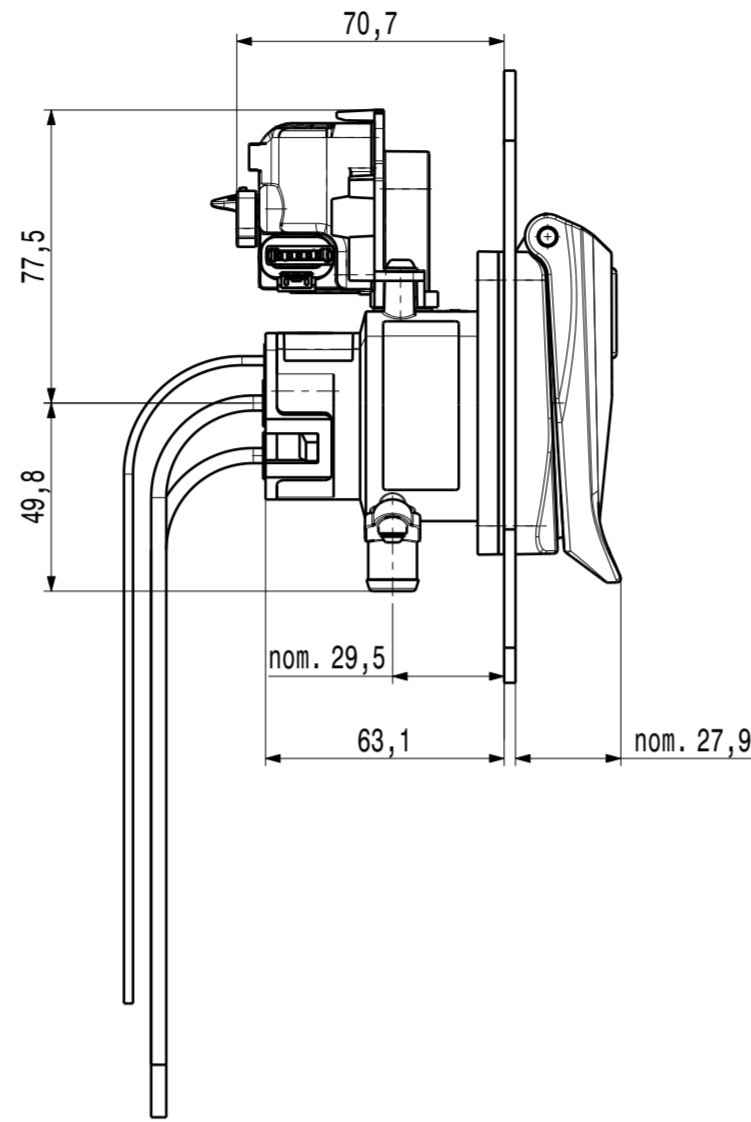
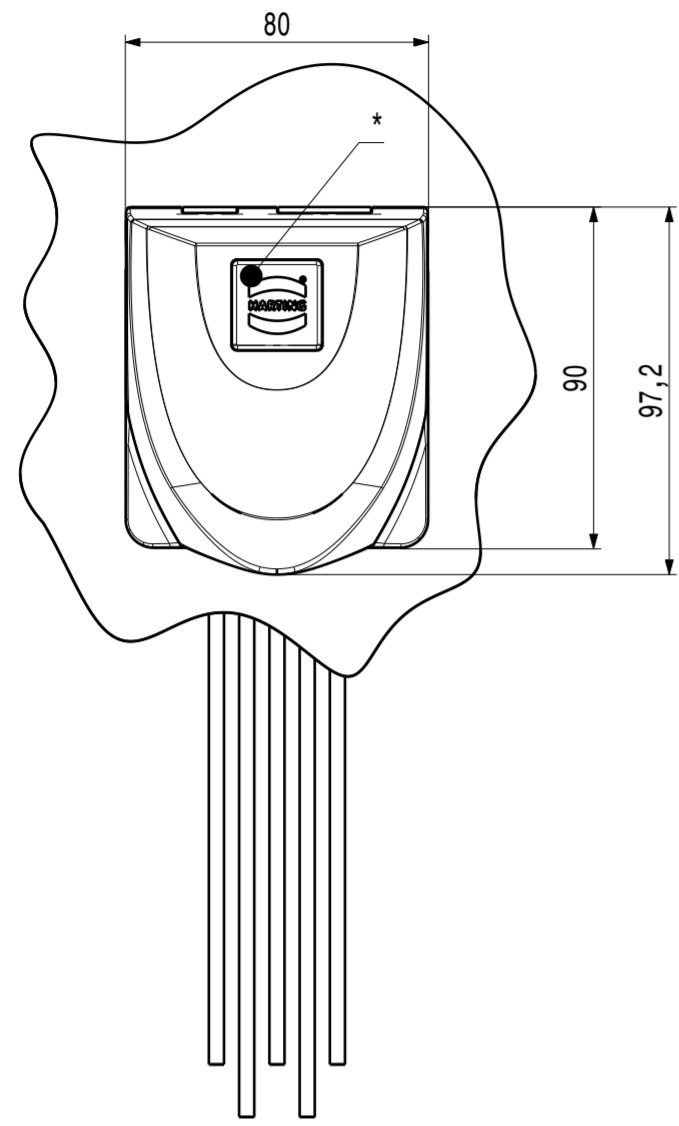
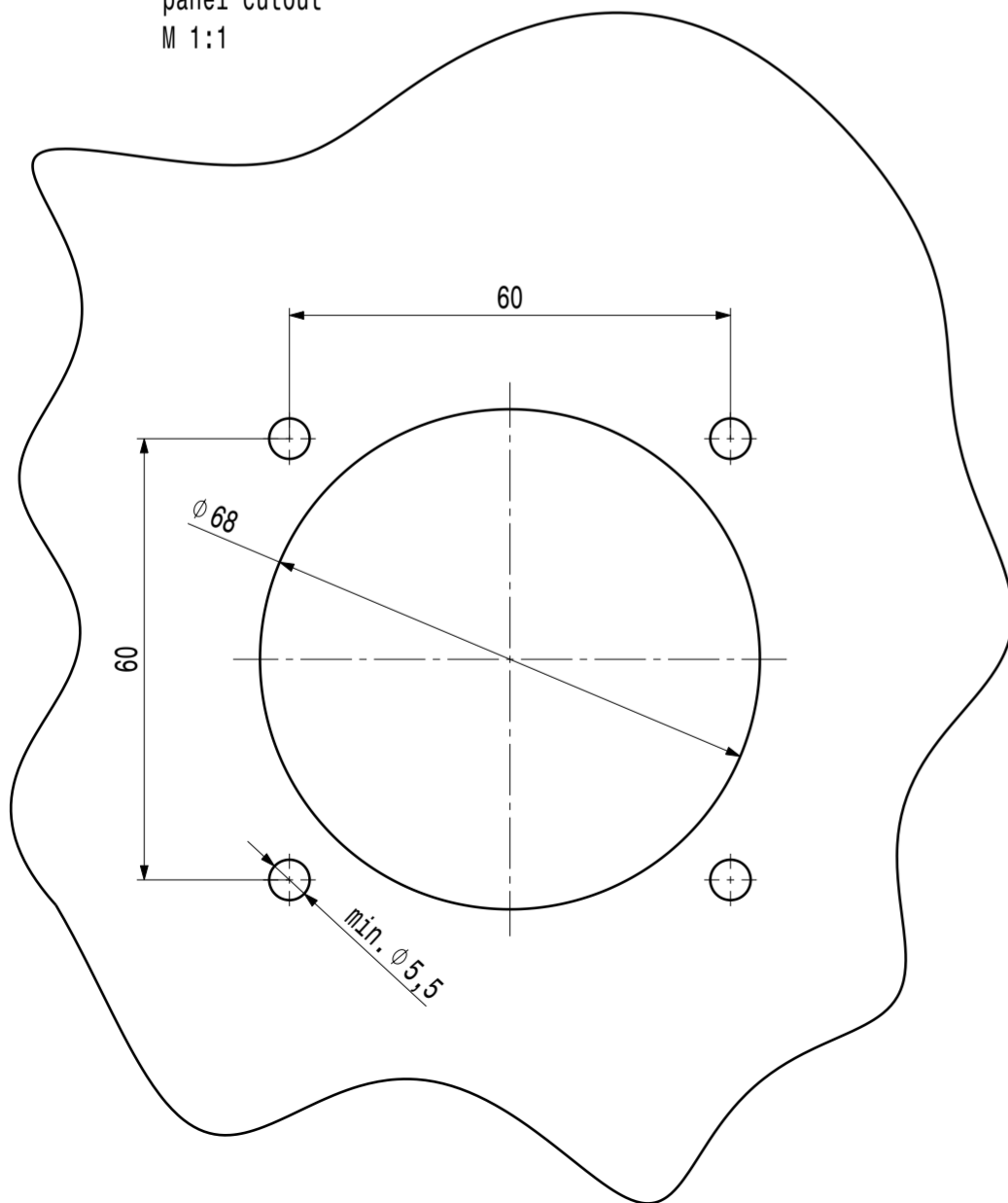

mating face acc. to  
IEC 62196-1:2015-06/62196-2:2017-11  
M 1:1

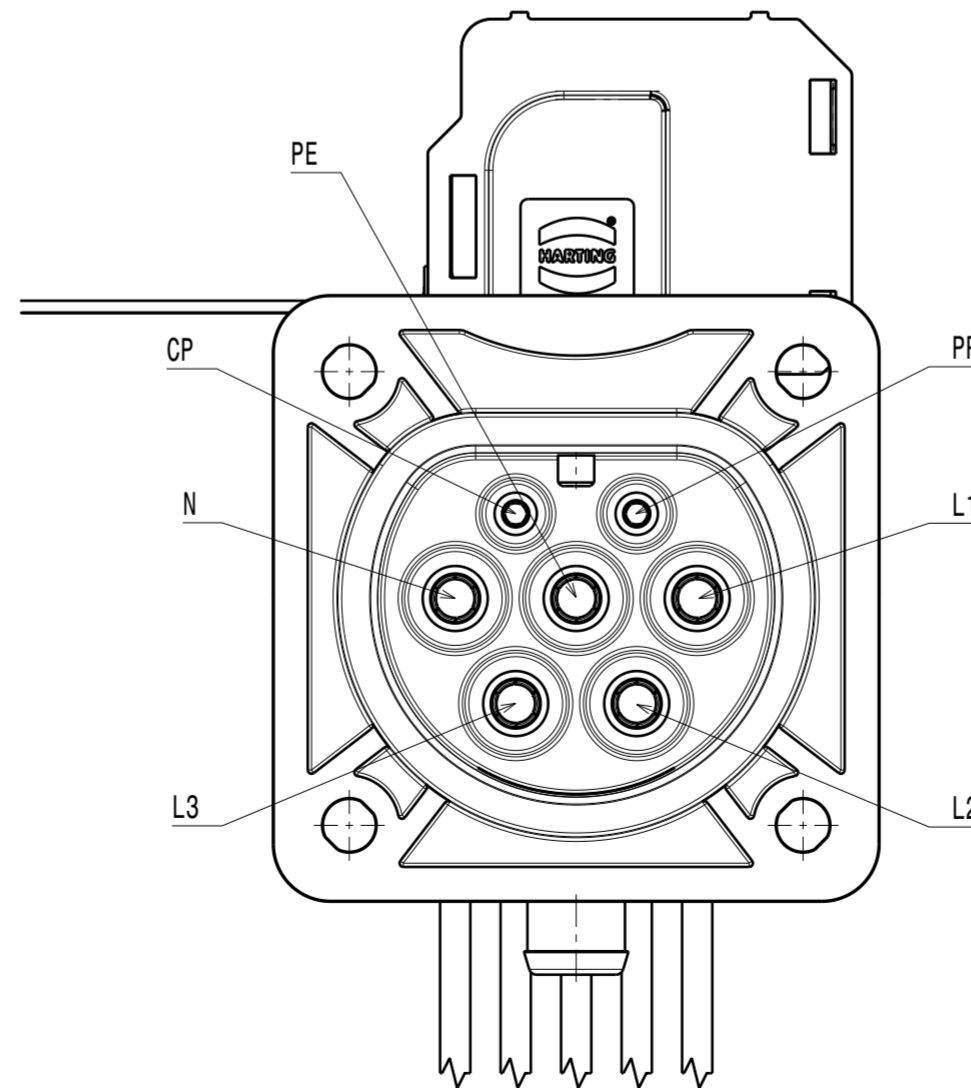

Type2 charging socket for the infrastructure side (IEC 62196-2:2017-11)  
charging mode 3  
rear panel mounting

3- 480V (AC)  
5x6mm<sup>2</sup> max. 22KW  
CP, PP: 0,5mm<sup>2</sup>

Washers and fixingscrews M5 accordingly to mounting situation  
(not included in scope of delivery)

\* 3D-Label position, optionally with customer branding (23,85x23,85)

Ä. Kennz. / mod.-sign		Index / Nr.		Mod. - Nr. / mod.-no		Bemerkung, Änderung / description of change		Datum / date	Name / name	Datum / date	Name / name
A000		52247						10.07.2023	Lin/Kipp		
Werkstückkanten nach ISO 13715 / edge finish acc. to ISO 13715		Oberflächengüte / surface quality		Oberflächenschutz / coating		Werkstoff / material					
Oberfl. in mm <sup>2</sup> / surface in mm <sup>2</sup>		Volumen in mm <sup>3</sup> / volume in mm <sup>3</sup>		Masse in g / mass in g		Benennung / title					
-		-		-		Type2 charging socket motorised locking					
alle Maße in mm / all dimensions in mm		Vertraulichkeitsklasse / class of confidentiality		Format / size		Teil-Nr. / part-no.		08 968 /020000		A000	
400<1000		-		A2		Maßstab / scale		1:2		Zeichnungs-Nr. / drawing-no.	
120<400		-		confidential		HARTING Automotive GmbH		D-32339 Espelkamp		Kunde / customer	
30<120		-				HARTING					
6<30		-									
<6		-									

Alle Rechte vorbehalten / All rights reserved  
Schutzvermerk ISO 16016 beachten / Refer to protection notice ISO 16016