

キャビティ & 金型番号
CAV & MOLD No.

トレードマーク
TRADE MARK

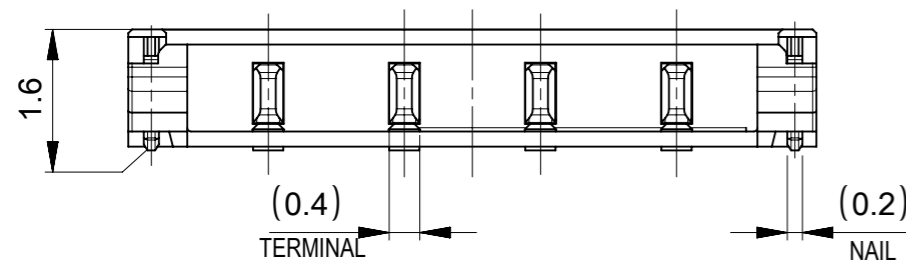
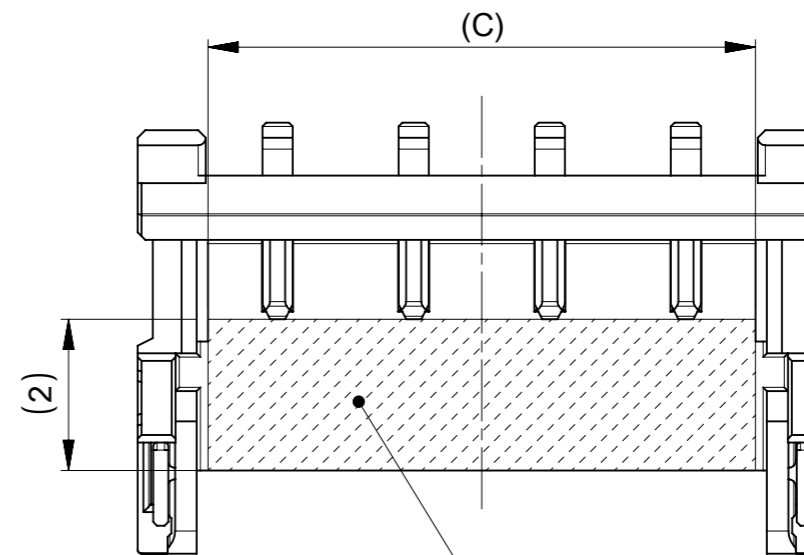
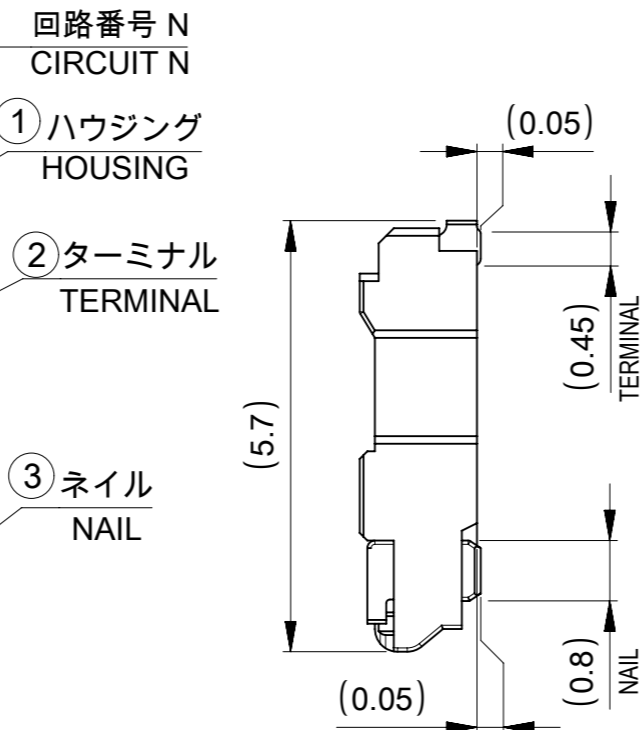
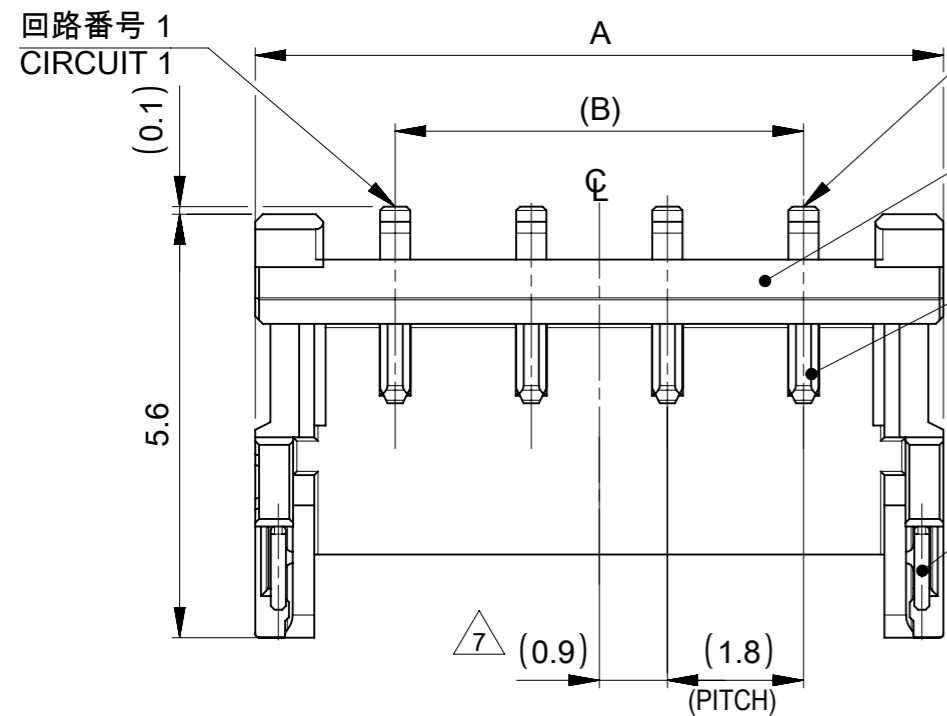
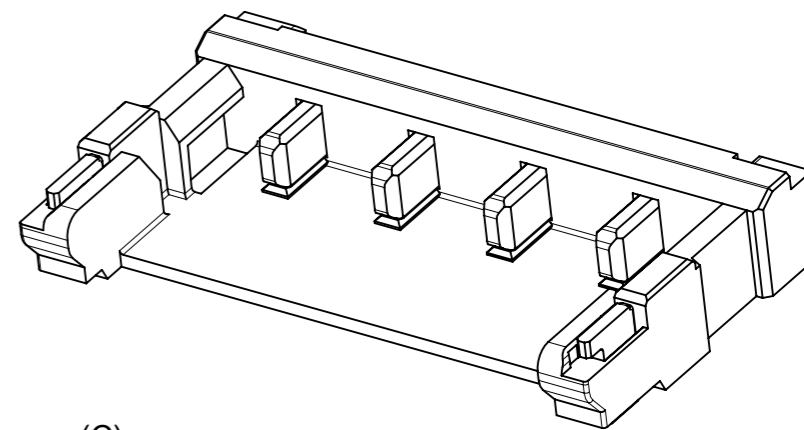

NOTES

- ① 材料及び仕上げ(めっき仕様) : TABLE 1 参照
MATERIAL AND FINISHES : SEE TABLE 1
- ② 製品仕様書 : 2082980000-PS
PRODUCT SPECIFICATION:2082980000-PS
- ③ 梱包形態 : SHEET 4 参照
PACKAGING INFORMATION : SEE SHEET 4
- ④ 嵌合相手 : 208298 シリーズ
MATES WITH:208298 SERIES
- ⑤ アプリケーション仕様書(コネクタ取扱い説明書) : 2166940000-AS
APPLICATION SPECIFICATION(CONNECTOR MANUAL):2166940000-AS
- ⑥ 端子テール部及びネイルの平坦度:0.1 MAX.
TAIL AND NAIL COPLANARITY TO BE 0.1 MAX.
- ⑦ 偶数極に適合
APPLY FOR EVEN CIRCUIT
- ⑧ 端子ネイルに錫めっきを使用している為、
外観に摺動痕が付く場合があります。
THE WOUND OF FRICTION MIGHT ADHERE TO EXTERNALS
BECAUSE THE TIN PLATING IS USED FOR THE NAIL.
- ⑨ 本製品のプラスチック部に黒点・白点等が確認される場合や
色合いが異なる場合がありますが、製品性能に影響はありません。
THERE IS NO INFLUENCE IN THE PRODUCT
PERFORMANCE THOUGH THE BLACK AND WHITE SPOT ETC.
MIGHT BE CONFIRMED TO THE PLASTIC PART OF
THIS PRODUCT AND THE SHADE MIGHT BE DIFFERENT.

① TABLE 1

番号 NO.	部品 PART	材質 MATERIAL
①	ハウジング HOUSING	ポリアミド(PA), UL94V-0, 色 : 黒 POLYAMIDE(PA), UL94V-0, COLOR : BLACK
②	ターミナル TERMINAL	黄銅 BRASS
		コンタクト部 : 金めっき 0.1 micro-meter MIN. CONTACT AREA : GOLD PLATING 0.1 micro-meters MIN. 半田付け部 : 金めっき TAIL AREA : GOLD PLATING ニッケルめっき(下地) : 1.0 micro-meter MIN. NICKEL PLATING (UNDER PLATING) 1.0 micro-meter MIN.
③	ネイル NAIL	黄銅 BRASS
		錫めっき : 1.0 micro-meter MIN. MATTE TIN PLATING ニッケルめっき(下地) : 1.0 micro-meter MIN. NICKEL PLATING (UNDER PLATING) 1.0 micro-meter MIN.
DOCUMENT STATUS	P1	RELEASE DATE 2023/03/07 05:52:54

9.04	7.2	10.9	5
7.24	5.4	9.1	4
5.44	3.6	7.3	3
3.64	1.8	5.5	2
C	B	A	極数 CIRCUIT SIZE

THIS DRAWING CONTAINS INFORMATION THAT IS PROPRIETARY TO MOLEX ELECTRONIC TECHNOLOGIES, LLC AND SHOULD NOT BE USED WITHOUT WRITTEN PERMISSION

DIMENSION UNITS	SCALE	CURRENT REV DESC.
mm	NTS	
GENERAL TOLERANCES (UNLESS SPECIFIED)		
ANGULAR TOL	± 3.0°	
4 PLACES	±	EC NO: 741094
3 PLACES	±	DRWN: SSHIMONISHI 2023/03/06
2 PLACES	± 0.2	CHK'D: AIDA 2023/03/07
1 PLACE	± 0.2	APPR: SAKIYAMA 2023/03/07
0 PLACES	± 0.2	INITIAL REVISION:
DRAFT WHERE APPLICABLE MUST REMAIN WITHIN DIMENSIONS		
THIRD ANGLE PROJECTION		
DRAWING	SERIES	MATERIAL NUMBER
A3-SIZE	208294	2082940000-SD
CUSTOMER		
GENERAL		
SHEET NUMBER		
1 OF 4		

molex

PICO-EZMATE HC 1.8WTB PLUG ASSY

PRODUCT CUSTOMER DRAWING

DOCUMENT NUMBER: 2082940000-SD, DOC TYPE: PSD, DOC PART: 000, REVISION: B

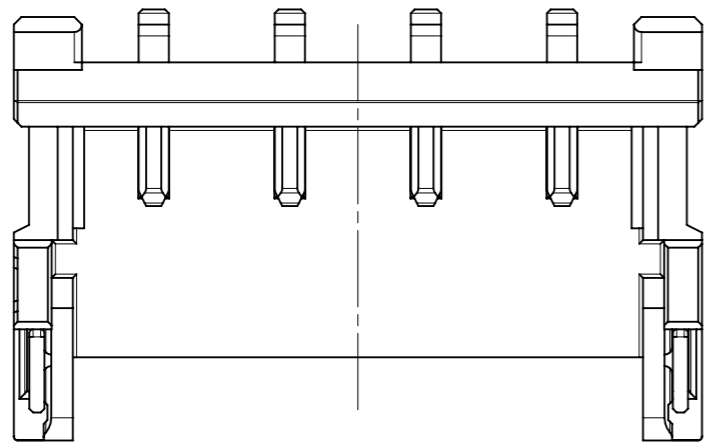

製品レイアウト
PRODUCT LAYOUT

嵌合相手：208298シリーズ
MATE WITH 208298 SERIES

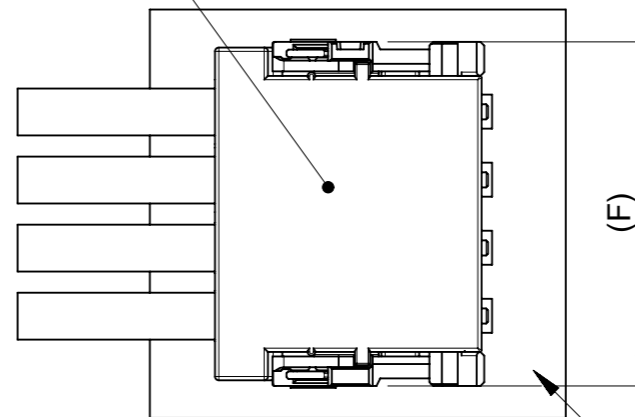

PCB

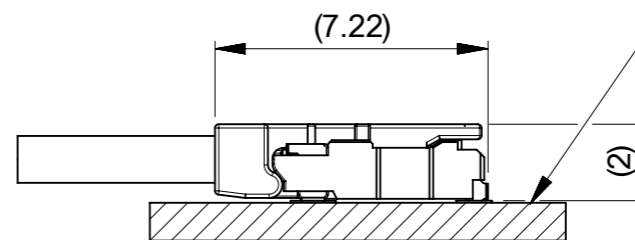

4 嵌合図
MATED CONNECTORES

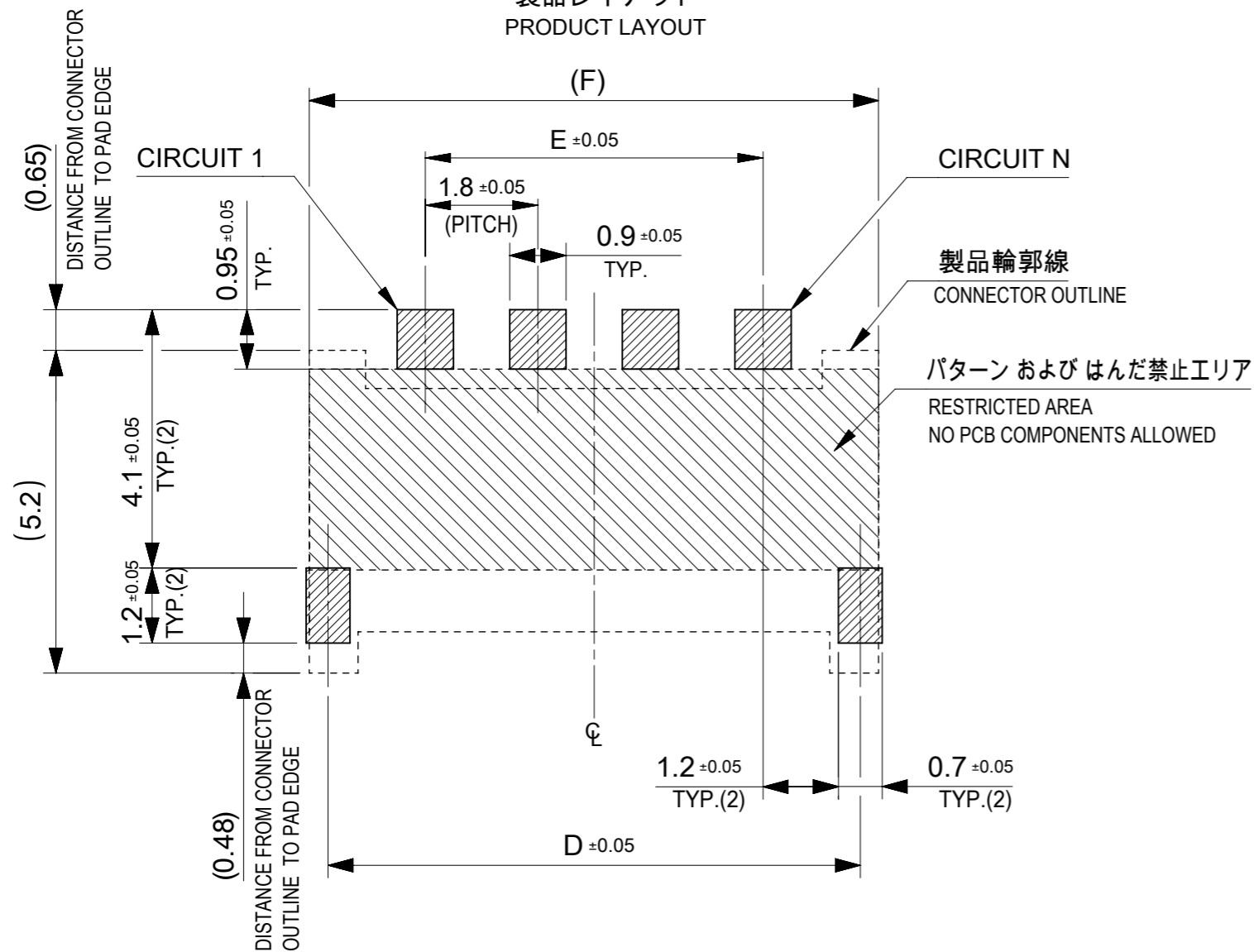

推奨基板レイアウト：実装面側
(参考：基板厚 1.0mm, メタルマスク厚さ 0.1mm, マスク開口率100%)

POLARIZED RECOMMENDED PCB LAYOUT : COMPONENT SIDE
(REFERENCE: PCB THICKNESS 1.0mm, STENCIL THICKNESS 0.1mm, APERTURE RATIO 100%)

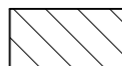
 :パターン禁止エリア
RESTRICTED AREA
NO PCB COMPONENTS ALLOWED

10.9	7.2	10.33	5
9.1	5.4	8.53	4
7.3	3.6	6.73	3
5.5	1.8	4.93	2
F	E	D	極数 CIRCUIT SIZE

THIS DRAWING CONTAINS INFORMATION THAT IS PROPRIETARY TO MOLEX ELECTRONIC TECHNOLOGIES, LLC AND SHOULD NOT BE USED WITHOUT WRITTEN PERMISSION		CURRENT REV DESC:		molex	
DIMENSION UNITS	SCALE	EC NO: 741094			
mm	NTS	DRWN: SSHIMONISHI 2023/03/06		PICO-EZMATE HC 1.8WTP PLUG ASSY	
GENERAL TOLERANCES (UNLESS SPECIFIED)		CHK'D: AIDA 2023/03/07		PRODUCT CUSTOMER DRAWING	
ANGULAR TOL	± 3.0°	APPR: SAKIYAMA 2023/03/07		DOCUMENT NUMBER	
4 PLACES	±	INITIAL REVISION:		DOC TYPE	
3 PLACES	±	DRWN: SSHIMONISHI 2022/07/22		DOC PART	
2 PLACES	± 0.2	APPR: SAKIYAMA 2023/01/30		REVISION	
1 PLACE	± 0.2	MATERIAL NUMBER		2082940000-SD	
0 PLACES	± 0.2	CUSTOMER		PSD 000 B	
DRAFT WHERE APPLICABLE MUST REMAIN WITHIN DIMENSIONS		THIRD ANGLE PROJECTION	DRAWING	SERIES	SHEET NUMBER
			A3-SIZE	208294	2 OF 4

コネクタ嵌合時の注意点

CAUTION WHEN MATING THE CONNECTOR.

コネクタはできるだけ嵌合軸と平行に嵌合させてください。
PLEASE MATE THE CONNECTOR IN PARALLEL WITH THE MATING AXIS AS MUCH AS POSSIBLE.

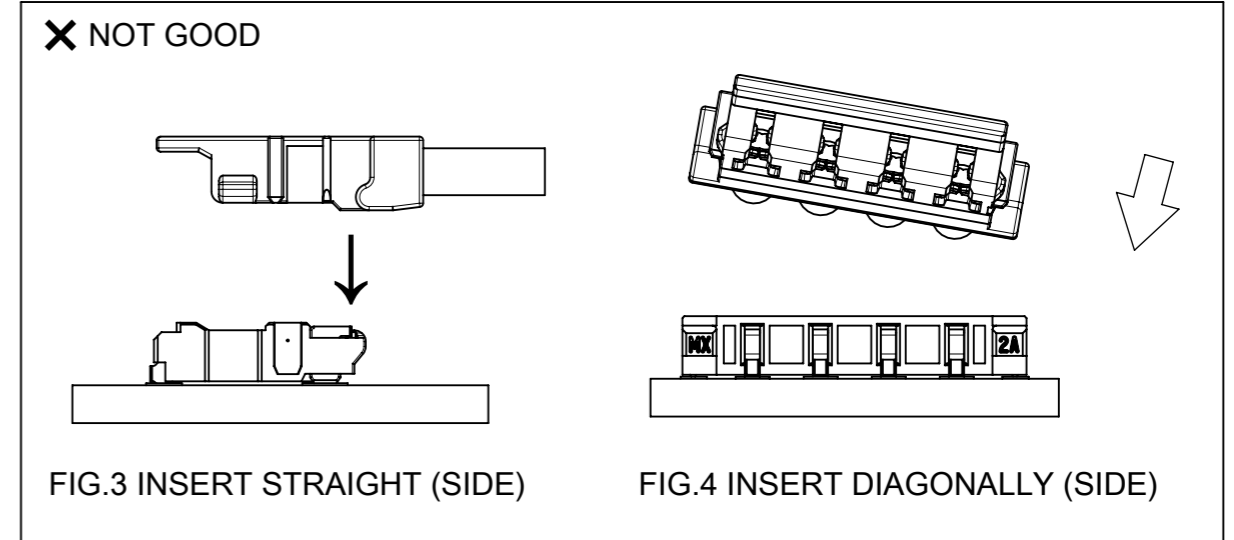
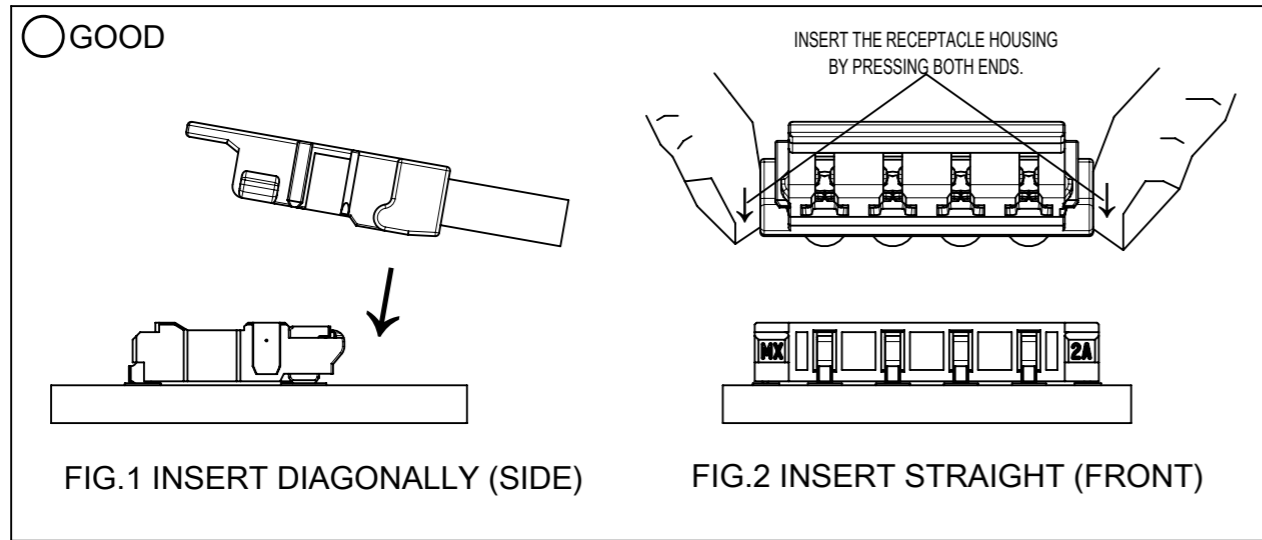

MATING

リセプタクルとプラグのハウジングのそれぞれのリアロック (FIG.6 ①) を合わせて位置決めした後、リセプタクルハウジングの矢印部分 (FIG.6 ②) を押して、プラグとリセプタクルハウジングがぶつかるまで嵌合させてください。
AFTER POSITIONING AND FACING EACH REAR LOCK (FIG.6 ①) OF BOTH RECEPTACLE AND PLUG HOUSING, PUSH THE ARROW PART OF RCEPTACLE HOUSING (FIG.6 ②) TO MATE UNTIL BOTH PLUG AND RECEPTACLE HOUSINGS STRIKE EACH OTHER.

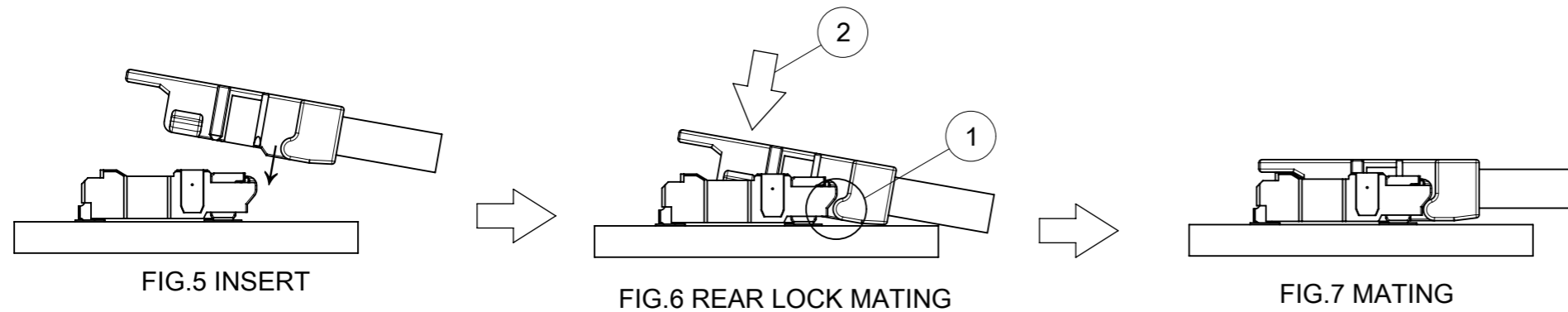

UNMATING

リセプタクルハウジングのロックTAB部(FIG.8 ③) に指をかけ、指の腹でロックTAB部を斜め上に持ち上げてロックを完全に解除し、リセプタクルハウジングをゆっくりと斜めに引き抜いてください。
PLEASE PLACE FINGERS ON THE LOCKING TAB (FIG.8 ③) OF THE RECEPTACLE HOUSING AND, USING THE FLAT OF FINGERS, RIFT THE LOCKING TAB UPWARD AT AN ANGLE TO FULLY RELEASE THE LOCK, THEN PLEASE WITHDRAW THE RECEPTACLE HOUSING SLOWLY AND DIAGONALLY.

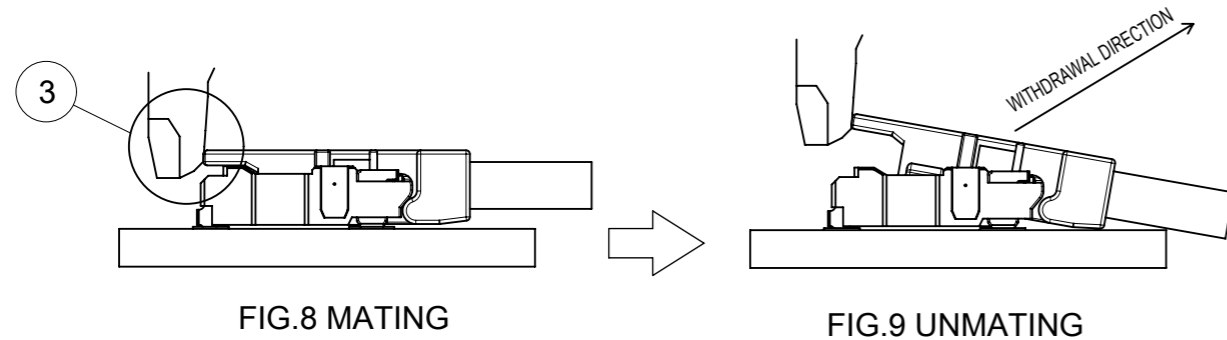

THIS DRAWING CONTAINS INFORMATION THAT IS PROPRIETARY TO MOLEX ELECTRONIC TECHNOLOGIES, LLC AND SHOULD NOT BE USED WITHOUT WRITTEN PERMISSION		CURRENT REV DESC:		molex	
DIMENSION UNITS	SCALE				
mm	NTS			PICO-EZMATE HC 1.8WTB PLUG ASSY	
GENERAL TOLERANCES (UNLESS SPECIFIED)				PRODUCT CUSTOMER DRAWING	
ANGULAR TOL	± 3.0 °			DOCUMENT NUMBER	
4 PLACES	±	EC NO: 741094	2023/03/06	2082940000-SD	
3 PLACES	±	DRWN: SSHIMONISHI	2023/03/07	DOC TYPE	DOC PART
2 PLACES	± 0.2	CHK'D: AIDA	2023/03/07	PSD	000
1 PLACE	± 0.2	APPR: SAKIYAMA		REVISION	B
0 PLACES	± 0.2	INITIAL REVISION:		SHEET NUMBER	
DRAFT WHERE APPLICABLE MUST REMAIN WITHIN DIMENSIONS		DRWN: SSHIMONISHI	2022/07/22	3 OF 4	
THIRD ANGLE PROJECTION		APPR: SAKIYAMA	2023/01/30		
DRAWING		SERIES	MATERIAL NUMBER	CUSTOMER	
A3-SIZE		208294	GENERAL		

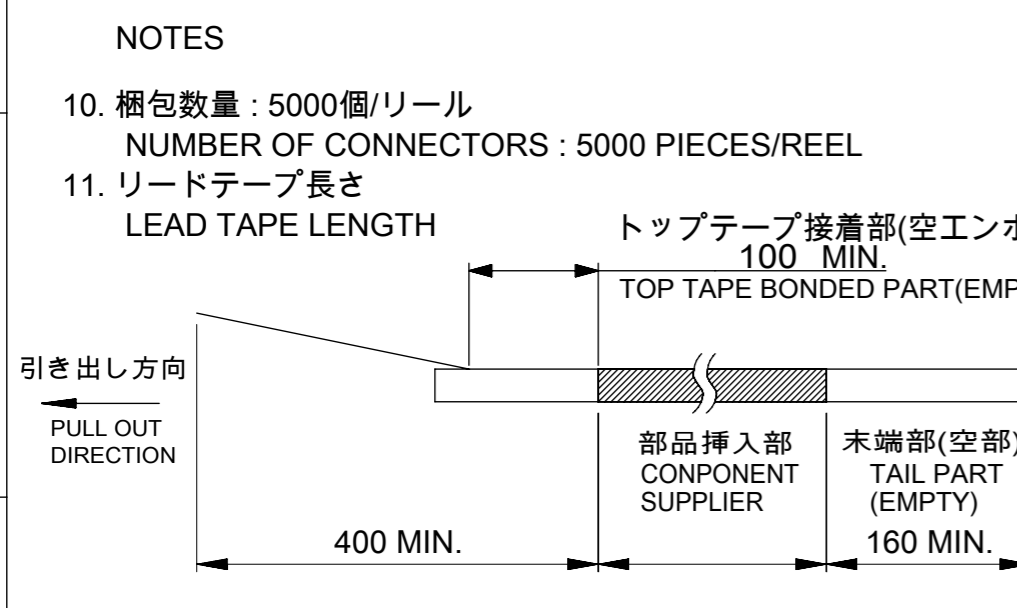
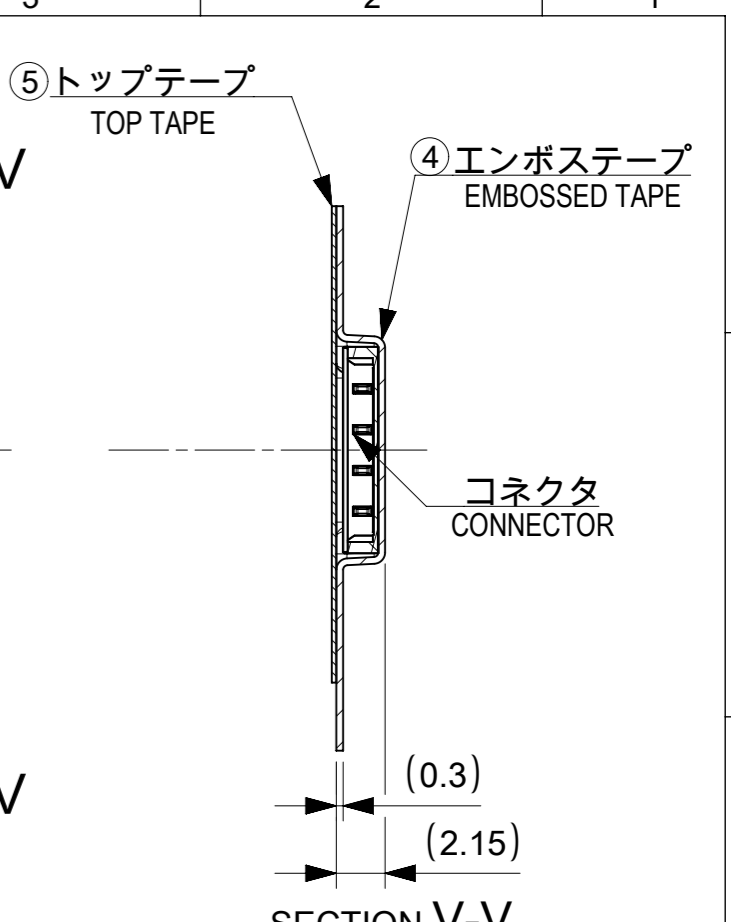
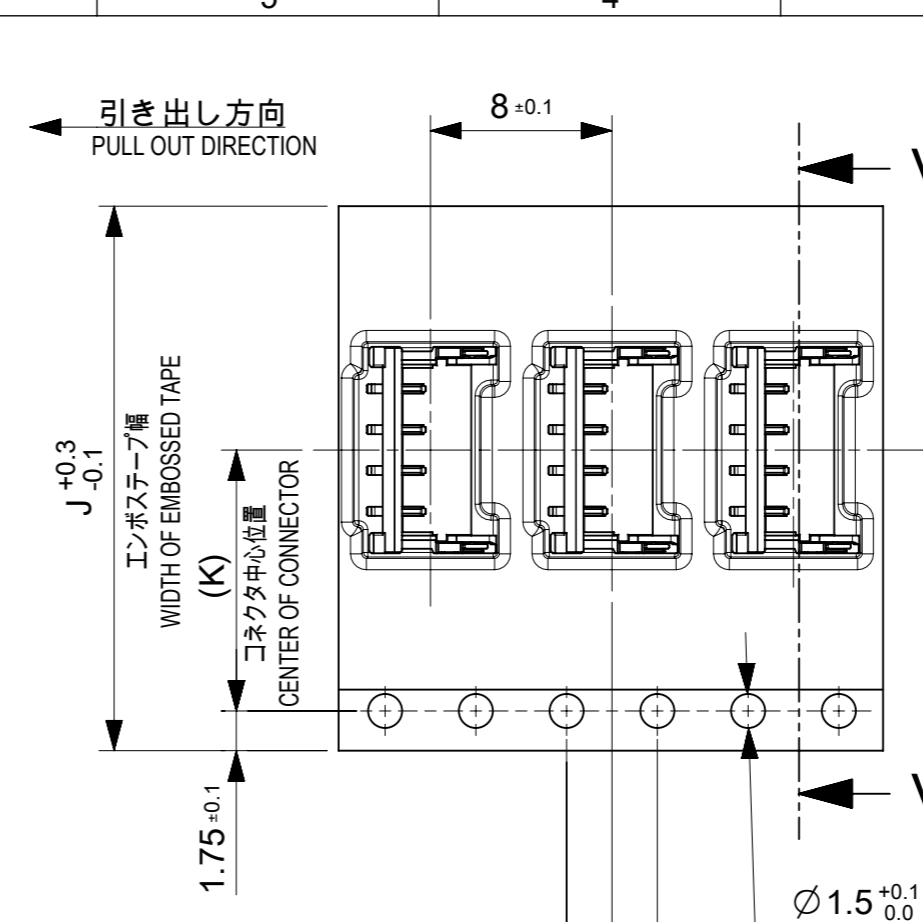
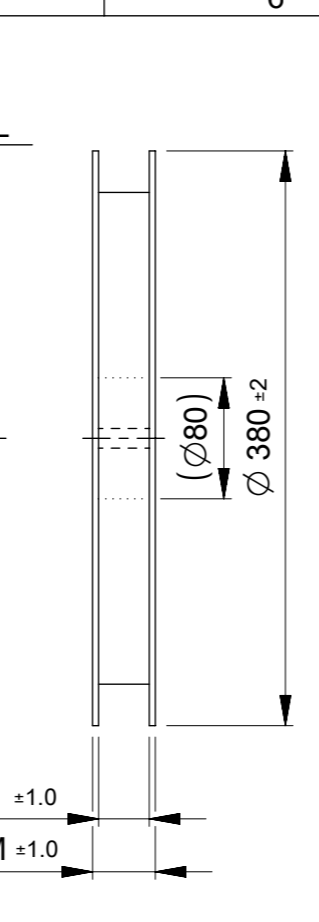
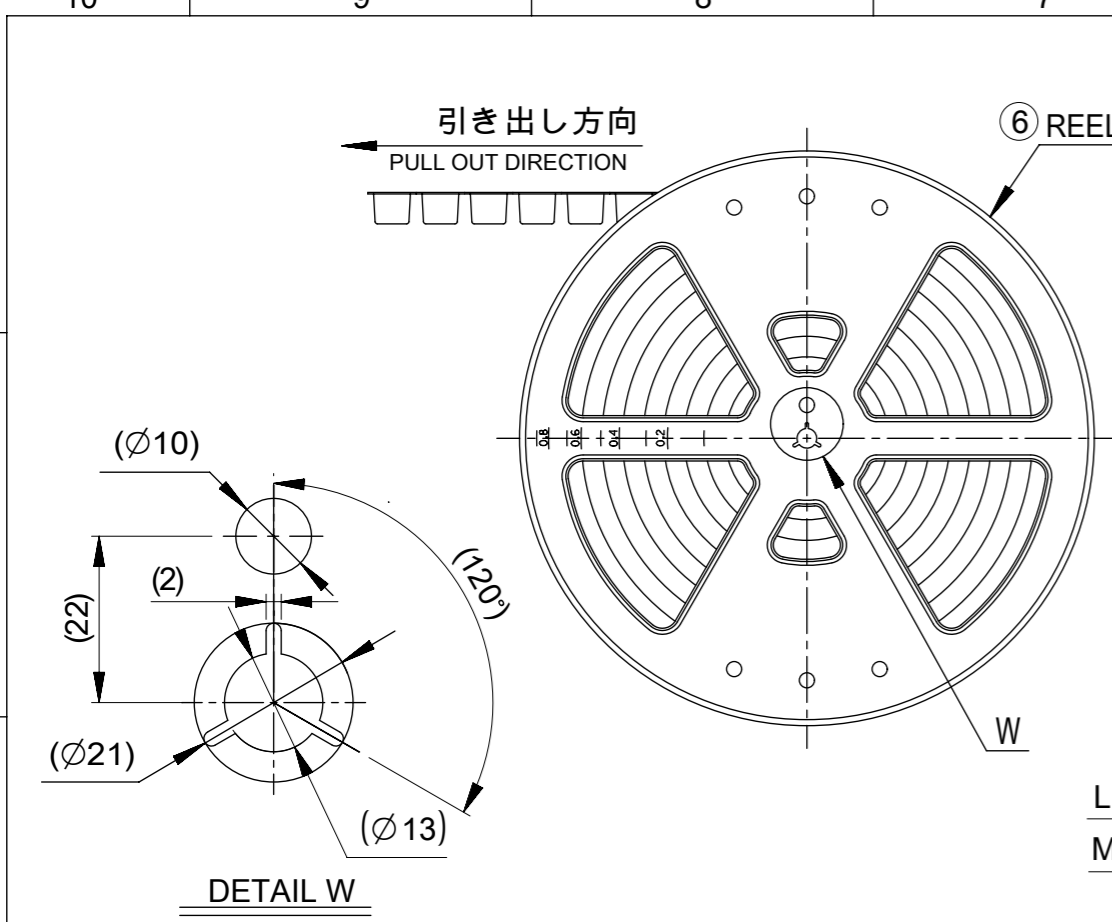

14 発注番号 : TABLE 参照
ORDER No. : PLEASE REFER TO TABLE.

208294 0 * * 0
極数
CIRCUIT SIZE

10. 梱包数量 : 5000個/リール
NUMBER OF CONNECTORS : 5000 PIECES/REEL
11. リードテープ長さ
LEAD TAPE LENGTH
12. トップテープの剥離強度はIEC60286-3に準拠。
TOP TAPE PEELING FORCE IS DEFINED BY IEC60286-3.
13. 梱包仕様書 : 2082949200-SPK
PACKAGING SPECIFICATION : 2082949200-SPK

(2) エンボスポケット中心位置
CENTER OF EMBOSSED POCKET

4 ± 0.1 累積ピッチ : 40 ± 0.2
ACCUMULATIVE PITCH:

29.5	25.5	11.5	24	2082940050	5
				2082940040	4
21.4	17.4	7.5	16	2082940030	3
				2082940020	2
M	L	K	エンボステープ幅 J WIDTH OF TAPE	14 発注番号 ORDER No.	極数 CIRCUIT SIZE
				PACKAGING STYLE : EMBOSSED TAPE AND REEL	

番号 NO.	部品 PART	材質 MATERIAL
④	エンボステープ EMBOSSED TAPE	ポリスチレン(PS)、その他 POLYSTYRENE(PS), etc
⑤	トップテープ TOP TAPE	ポリエチレン(PE)、その他 POLYETHYLENE(PE), etc
⑥	リール REEL	ポリスチレン(PS) <リサイクル材を含む> POLYSTYRENE(PS) <RECYCLE MATERIAL CONTAINED>

THIS DRAWING CONTAINS INFORMATION THAT IS PROPRIETARY TO MOLEX ELECTRONIC TECHNOLOGIES, LLC AND SHOULD NOT BE USED WITHOUT WRITTEN PERMISSION									
DIMENSION UNITS mm		SCALE NTS		CURRENT REV DESC.					
GENERAL TOLERANCES (UNLESS SPECIFIED)									
ANGULAR TOL ± 3.0°		4 PLACES ±		3 PLACES ±		2 PLACES ± 0.2		1 PLACE ± 0.2	
0 PLACES ± 0.2		DRAFT WHERE APPLICABLE MUST REMAIN WITHIN DIMENSIONS		THIRD ANGLE PROJECTION		DRAWING A3-SIZE		SERIES 208294	
DOCUMENT NUMBER 2082940000-SD				DOC TYPE PSD		DOC PART 000		REVISION B	
MATERIAL NUMBER SEE TABLE				CUSTOMER GENERAL					
SHEET NUMBER 4 OF 4									