

Lötösen 0,6 x 2,0mm / solder eyelets 0,6 x 2,0mm
 Isolierwerkstoff / housing material : PBT GF 30
 Anforderungsstufe 2 = 400 Steckzyklen / performance class 2 = 400 mating cycles
 Bauart 7 / type 7

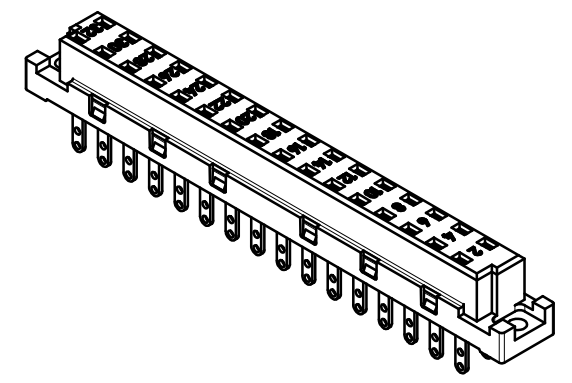
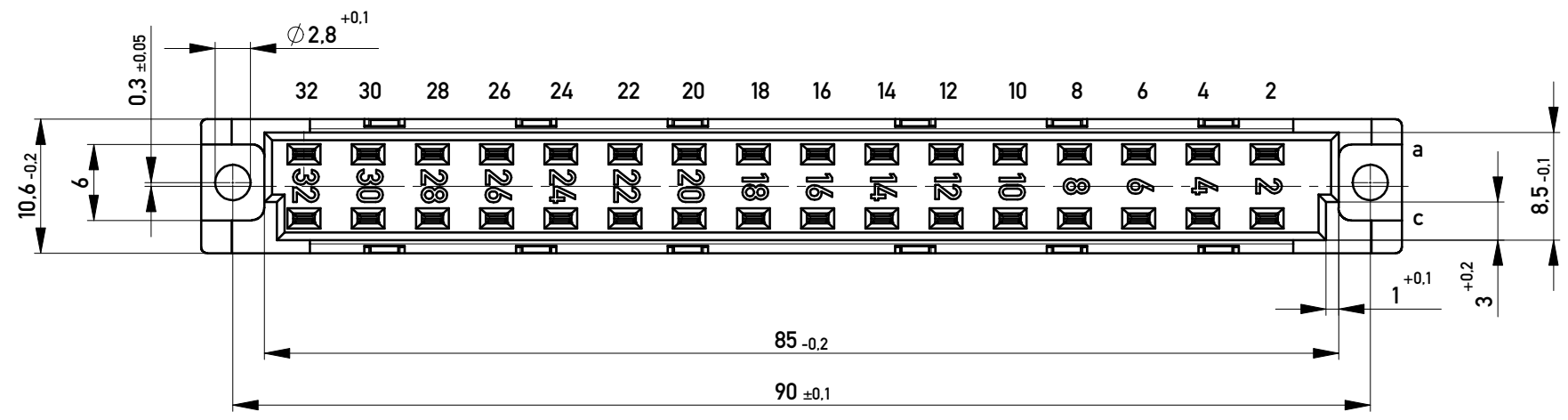

Fehlende Masse und Angaben nach DIN EN 60603-2 / Missing information and dimensions according to DIN EN 60603-2
 Sonstige Angaben siehe Fertigungsunterlagen / Additional indications please see the production documentation

Information: All rights reserved. Only for Information. To ensure that this is the latest version of this drawing, please contact one of the ERNI companies before using.	Tolerances All Dimensions in mm	Scale	2:1
		Designation Federleiste D 32 Löt Fem Connector D 32 Solder	
Copyright by ERNI GmbH Proprietary notice pursuant to ISO 16016 to be observed.	Subject to modification without prior notice. Drawing will not be updated.	www.ERNI.com	
		c Index	06.05.2013 Date