

PCB MOUNTING HOLES(±0.1)
(COMPONENT SIDE)

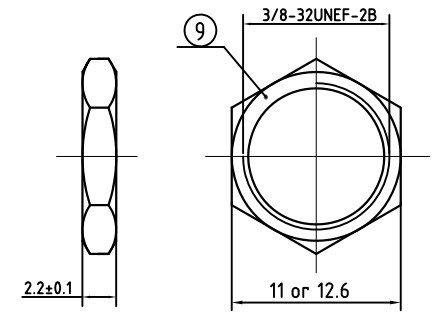
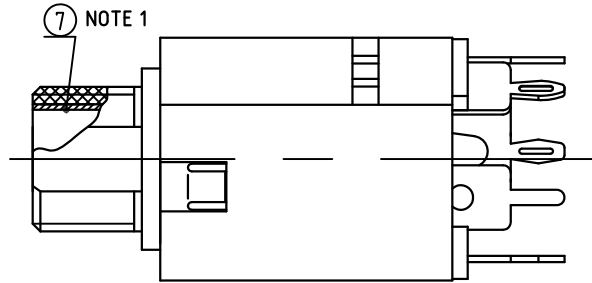

HEX NUT

FLAT WASHER

PART No.	ACJM-MIV-2	ACJM-MIV-2S	ACJS-MIV-3	ACJS-MIV-3S	ACJS-MIV-5
SCHEMATIC					

NO.	NAME	QTY	MATERIAL(THICK,COLOR)	REMARK
9	HEX NUT	1	H59 (COPPER ALLOY)	Ni-PLATED(Cu:2-3um, Ni:2-3um) RoHS COMPLIANT
8	FLAT WASHER	1	H62Y OR STEEL t=0.5	
7	METAL TUBE	1	H59 (COPPER ALLOY)	
6	BODY	1	PBT G10 94HB	RoHS COMPLIANT
5	5# TERMINAL	1	H62Y t=0.4 (C2680R-H)	Ag-PLATED(Cu:2-3um, Ag:0.3um) RoHS COMPLIANT
4	4# TERMINAL	1	H62Y t=0.4 (C2680R-H)	
3	3# TERMINAL	1	QSn6.5-0.1Y t=0.35 (C5210R-H)	
2	2# TERMINAL	1	QSn6.5-0.1Y t=0.4 (C5210R-H)	
1	1# TERMINAL	1	QSn6.5-0.1Y t=0.4 (C5210R-H)	

NOTE 1: METAL TUBE IS NOT CONNECTED TO TERMINAL 1

UNLESS OTHERWISE SPECIFIED TOLERANCE TO BE		THIS DOCUMENT IS THE PROPERTY OF AMPHENOL AUSTRALIA PTY. LTD.. NO PART THEREOF MAY BE REPRODUCED AND USED WITHOUT THE PRIOR WRITTEN CONSENT OF THE OWNER			
LINEAR	ANGULAR	CAD FILE:	DRN:	DATE:	TITLE:
X ± 0.5 X.X ± 0.20 X.XX ± 0.10	X° ± 1° X'X' ± 30' X'X'X' ± 15'	55010639000111	M.H	19-11-09	6.5mm INSULATED VERTICAL JACK CUSTOMER DRAWING
BREAK ALL SHARP EDGES AND REMOVE ALL BURRS		MATL:	SEE TABLE	CKD:	M.H.
DO NOT SCALE		FINISH:	SEE TABLE	APP'D:	M.H.
DIMENSIONS IN MILLIMETRES		SCALE:	NTS	DATE:	31-10-18
THIRD ANGLE PROJECTION		PART No:	SEE TABLE	DATE:	31-10-18

REV.	DESCRIPTION	BY	DATE	CHG/No
1	CORRECT CONTACT IDS TO MATCH SCHEMATIC DIAGRAM	M.H	31-10-18	9511
0	FIRST ISSUE	M.H	19-11-09	----

Amphenol	DRAWING NO.	SHEET
Amphenol Australia Pty.Ltd, 22 Industry Blvd, Corrum Downs, Vic.3201	55010639-000-1	1 OF 1