

ALU-Handelsverpackung / All rights reserved
 Schutzzeichen ISO 15708 Hersteller / Never to print on October 200 15708

8	7	6	5	4	3	2	1
Artikelnummer /article number	Typ /type	Ausführung /version	Phasen /phases	Konfektionierung /configuration	Kupfergewicht /copperweight (gr)		
8811758008880A1	Type 2	VDE 32A	1-phase	End open	1362		

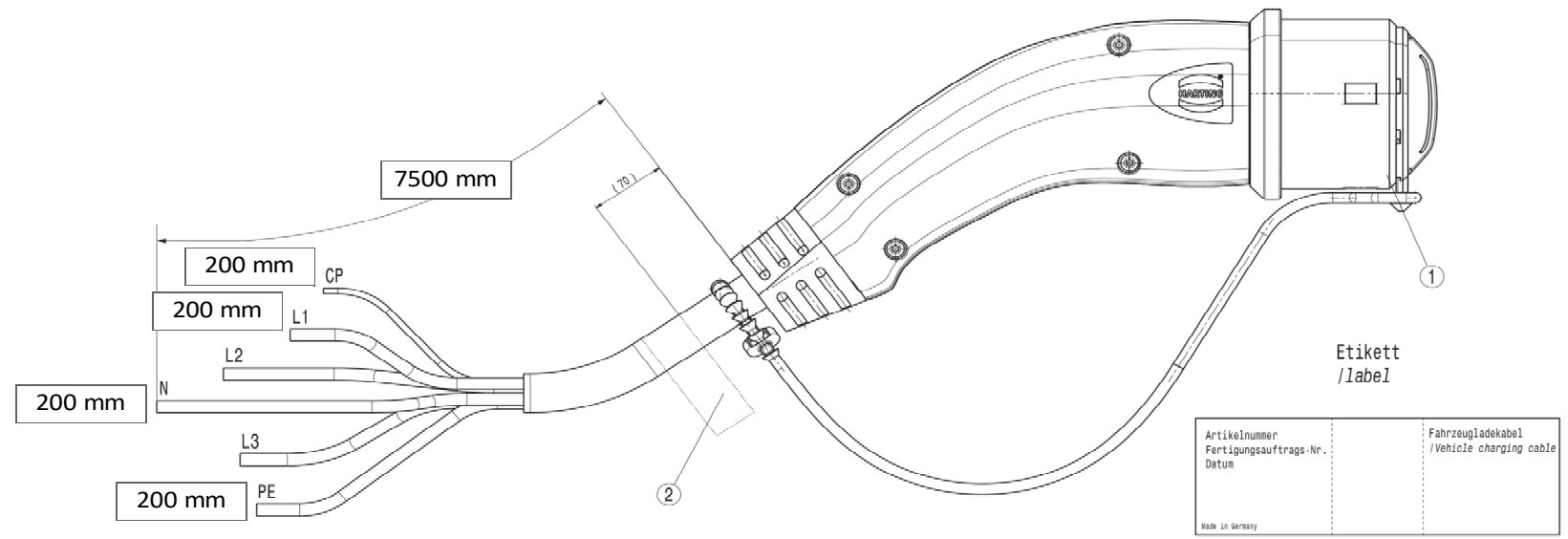

**Belegung
/pinning**

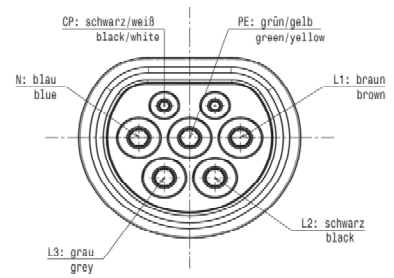

**Kabel/Ader Längtoleranz
Cable/Wire Length Tolerance**

Length /mm	Tolerance /mm
<200	±5
>4000 - 8000	±50

** Je nach Konfektionierung /depends on configuration

Pos. item	Anzahl number	Einh. unit	Benennung title
4**	**	St	Aderendhülse Steuerung /cable sleeve signal
3**	**	St	Aderendhülse Leistung /cable sleeve power
2	1	St	Etikett /label
1	1	St	Fahrzeugladestecker /vehicle connector

Index	Mod.-Nr.	Bemerkung, Änderung	Datum	Name	Datum	Name
Index	Mod.-Nr.	description of change	date	name	date	name
			04.09.2020	Boesch		
				gezeichnet		Konstr. - Freigegeben
				drawn by		design approval
Werkstückdaten nach ISO 12715 edge finish acc. to ISO 10775		Oberflächengüte surface quality	Oberflächenschutz coating	Werkstoff material		
		Oberfl. in cm ² surface in cm ²	Volumen in cm ³ volume in cm ³	Masse in g mass in g		
		Form/size		Benennung title		
		A2		Fahrzeugladekabel /vehicle charging cable		
		1:1		Teil-Nr. part-no.		
		HARTING Automotive GmbH D-32339 Espelkamp		Zeichnungs-Nr. - Kurze drawing-no. - cut table		