

Slide rail

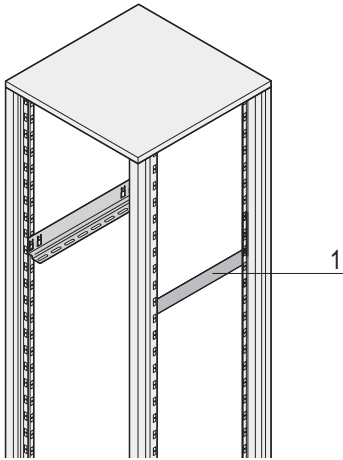

c = pitch of the 19" uprights

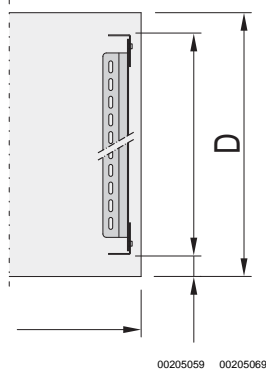

00205059 00205069

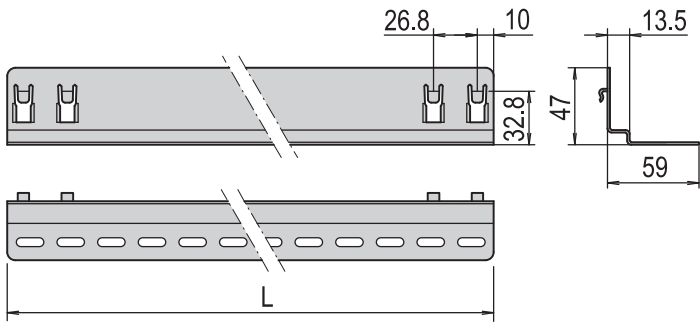

L = length

41003080

- For safe and simple installation of heavy 19" subracks
- Can be hung into the upright at 1 U increments
- Load-carrying capacity max. 25 kg per pair

Delivery comprises

Item	Qty	Description
1	10	Slide rail for insertion, St, 1.5 mm, surface AlZn
2	1	Assembly kit

Order Information

For cabinet depth mm	Length L mm	c mm	x _f mm	Part no.
600	417	480	60	21127-197
800	617	680	60	21127-198

Note

- Can only be fitted to 19" upright
- Further dimensions available on ServicePLUS, see from page 1.298



For further information www.schroff.biz/oneclick
oneClick search code = Part no.

Short slide rail

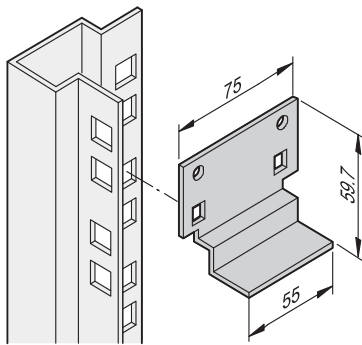

sc96xxxx

- For mounting on the vertical cabinet uprights
- Can be hung at 1 U increments
- Static load-carrying capacity 15 kg max per pair

Delivery comprises

Item	Qty	Description
1	2 / 10	Short slide rail, St, 1,5 mm, finish AlZn
2	1	Assembly kit

Order Information

Description	Qty/PU	Part no.
Short slide rail	2	20118-592
Short slide rail	10	20118-593



For further information www.schroff.biz/oneclick
oneClick search code = Part no.