

Test adapters

6/9 U test adaptors

6 U

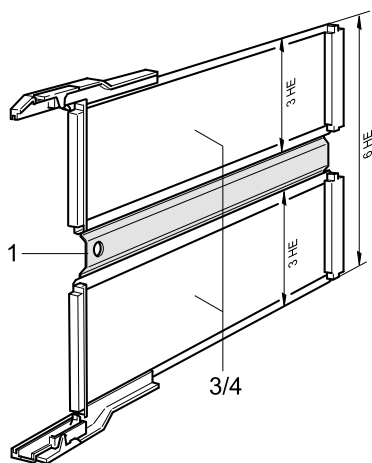

- Suitable for types B, C, D, E, F
- 6 U test adaptor can be made from:
 - 2 x equal length 3 U test adaptors (3/4)
 - 1 x intermediate adaptor 6 U (1)
 - or
 - 1 x 3 U test adaptor (3/4)
 - 1 x bare board (item 2 without connector)
 - 1 x intermediate adaptor 6 U (1)
- 9 U test adaptor can be made from:
 - 3 x equal length 3 U test adaptors (3/4)
 - 2 x intermediate adaptor 9 U (1)
 - or
 - 2 x 3 U test adaptors (3/4)
 - 1 x bare board (item 2 without connector)
 - 2 x intermediate adaptor 9 U (1)
 or other combinations
 test adaptor item 4, type x
 bare board: item 3

A4-2550

9 U

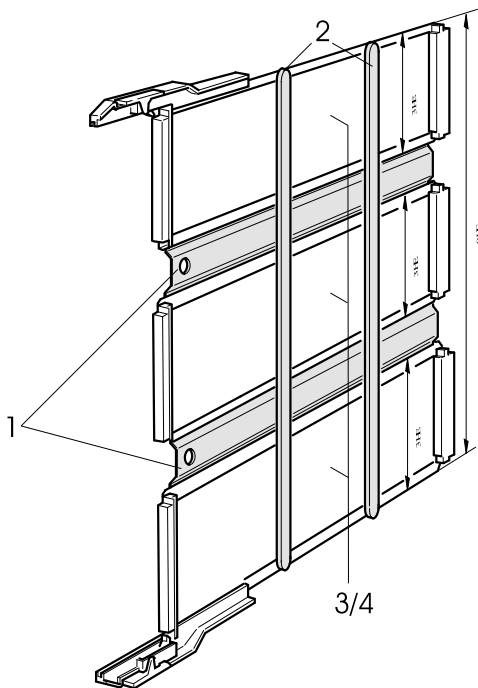

Delivery comprises (kit)

Item	Qty		Description
	6 U	9 U	
1	1	2	Intermediate adaptor, St, 1.5 mm, grey, incl. assembly kit
2	–	2	Board stiffener

Order Information

Description	For board depth mm	For test adaptor depth (dimension B) mm	Part no.
6 U	160	290	20800-224
6 U	220	350	20800-168
6 U	280	410	20800-278
6 U	340	470	20800-279
9 U	220	350	23040-001

Accessories

Bare board (item 2) 3 U, 160 mm deep without connector, 1 piece	23040-006
Bare board (item 2) 3 U, 220 mm deep without connector, 1 piece	23040-007

Note

- Test adaptor type D cannot be combined with other types
- Test adaptor depth (dimension B) of VMEbus test adaptors see page 10.25
- Test adaptor depth (dimension B) at type B, C, D, E, F, see page 10.28



For further information www.schroff.biz/oneclick
oneClick search code = Part no.