

# DRAINAGE DEVICE

DD 084 | IP66 / IP67 / IP69K



Photo: Inside view

- > High degree of protection

> Good drainage performance

> Easy to install
- > Robust, weather and UV-light protected housing

Condensate occurs in enclosures and housings with high protection type by variations in temperature. The use of a drainage device allows the conveying of the condensate without losing the maximum protection type of IP66. The water permeable membrane makes sure the drainage of the enclosure by the capillary attraction. The construction prevents the infiltration of splash water into the enclosure.



## TECHNICAL DATA

Mounting	thread M50 x 1.5 with nut (wrench size 60 mm, housing 50 mm)
Torque	6 Nm max.
Depth in enclosure	max. 17.5 mm
Material	plastic according to UL94 V-0, umbra grey, weather proof and UV light resistant according UL746C (f1)
Water entry height	0 mm (at 0.5 mm wall thickness)
Sealing	sealing gasket NBR
Water flow-through	approx. 200 ml/h at a water column of 5 mm
Dimensions	Ø 60 x 49.5 mm
Fitting position	horizontal, lowest point
Operating/Storage temperature	-45 to +70 °C (-49 to +158 °F)
Approvals	EAC

**Installation:** Make cut-out Ø 50.5<sup>+0.5</sup> mm in enclosure bottom and mount drainage device with nut. Please make sure that the sealing gasket is put in place on the outer side panel of the enclosure and the hole is free of burrs.

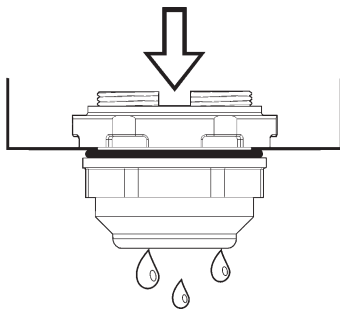

Fitting position

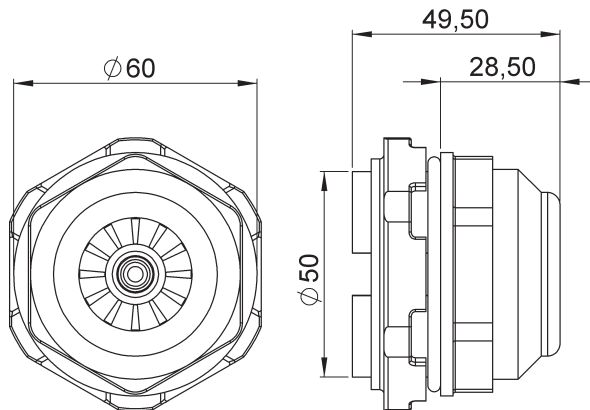

Art. No.	Protection type	Enclosure wall thickness	1 package unit	Weight (approx.)
08410.0-00	IP66 / IP67 (EN 60529) / IP69K (EN 40050-9)	0.5 - 5.5 mm	1 piece	60 g