



## OUT of the Box Startup – Overview



This document is intended as a quick start guide to get familiarity with keypad navigation, changing parameters, and setting the RS510 drive up for external start/stop and external potentiometer signal. Please note this document is not a substitute for the RS510 User Manual and it is important that you reference the RS510 user manual before proceeding.

### STEP 1 Check Nameplate and Connect Input / Output Wiring -

Check the inverter nameplate to insure that the information agrees with your order. Also insure that the power available is rated appropriately for the drive being used.

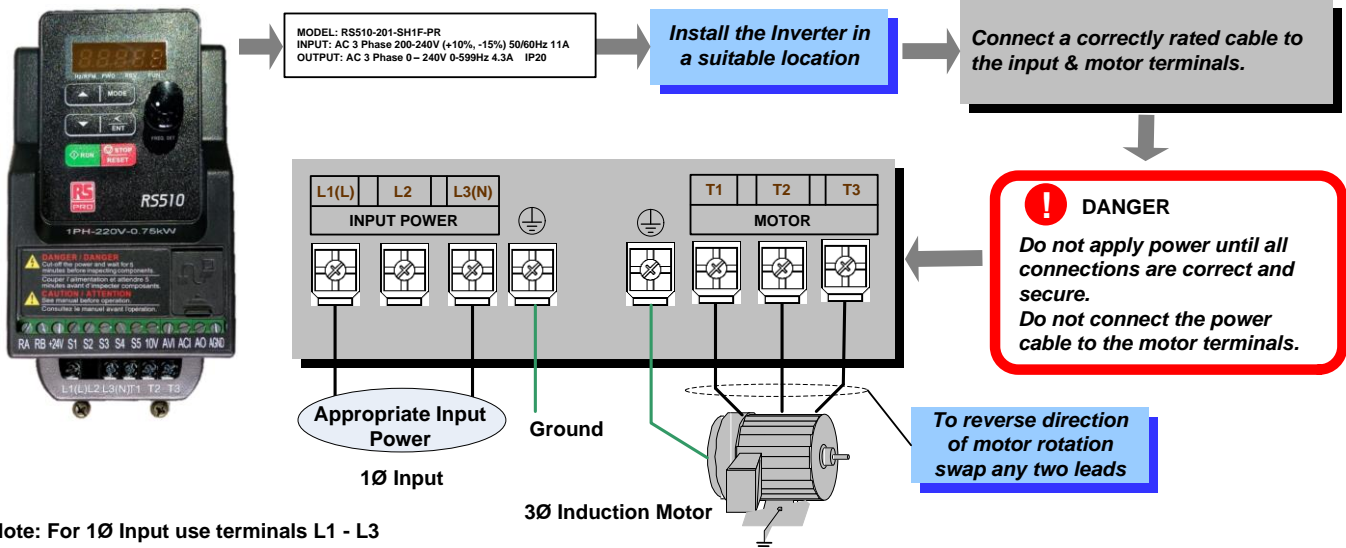

### STEP 2 Power-up the Inverter, check the Digital Operator

In this step, after the initial power-up you will become familiar with the indications and functions of the Digital Operator.

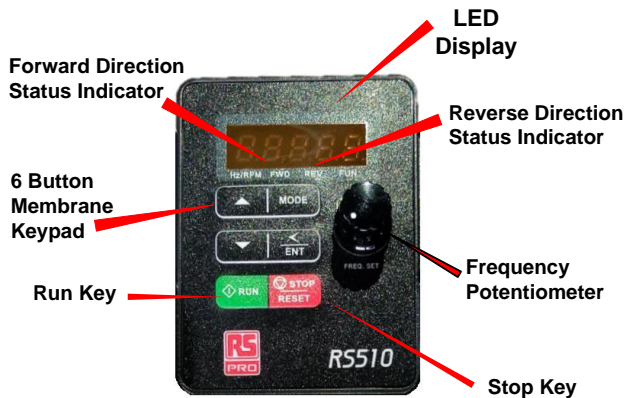

#### RS510 Control Settings (Factory Default)

##### RUN/STOP Control: Keypad (RUN / STOP key)

Press RUN to start the drive or STOP to stop the drive.

See **step 5.** to change to RUN/STOP to external switch/contact.

##### SPEED Control: Keypad (Default 5.00 Hz)

See **step 6.** to change to external potentiometer control.



**Flashing**

##### Changing Speed Reference

Press </ENT button and use ▲▼ to change reference.

Press </ENT button to save

#### KEYS (8) Description

**RUN:** RUN Inverter in Local Mode

**STOP / RESET:** STOP Inverter, RESET alarms and faults

▲:Parameters navigation Up, Increase parameters or reference value  
 ▼:Parameters navigation Down, decrease parameters or reference value

**MODE:** Switches between available displays

</ENTER: "<" Left Shift: Used to change parameters or values, ENTER: used to display the preset value of parameters and to save changes

### STEP 3 Check Motor Rotation

This test is to be performed solely from the inverter keypad. Apply power to the inverter after all the electrical connections have been made. At this point, **DO NOT RUN THE MOTOR**, the keypad should display as shown below in Fig. 1a and the speed reference 5.00 Hz should be blinking.



Next press the **RUN** key. The motor should now be operating at low speed running in forward (clockwise) direction. The keypad should display as shown above in Fig. 1b and the speed reference 5.00 Hz should be solid. Next press **STOP** key to stop the motor.

If the motor rotation is incorrect, power down the inverter. After the power has been turned OFF, wait at least ten minutes until the charge indicator extinguishes completely before touching any wiring, circuit boards or components.

Using Safety precaution, and referring to step 1 exchange any two of the three output leads to the motor (T1, T2 and T3). After the wiring change, repeat this step and recheck motor direction.

### STEP 4 How to Change Parameters (Example 03-03 change to 6)

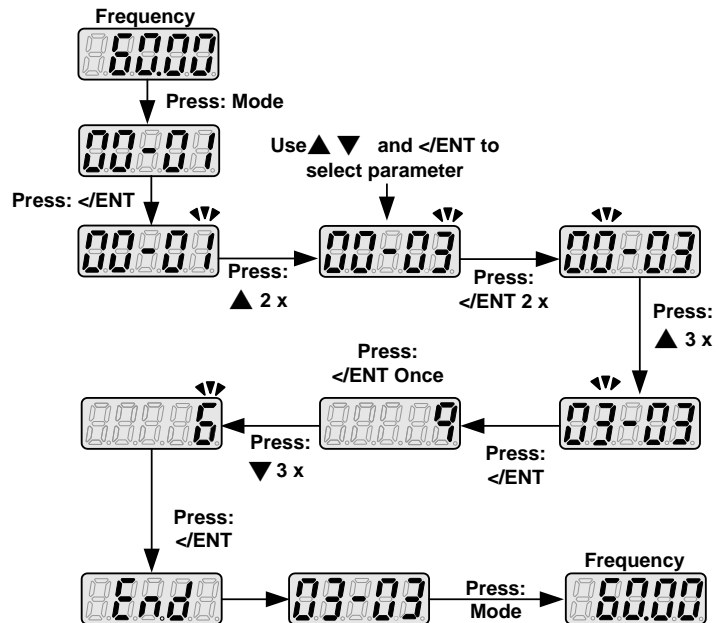

### STEP 5 Using Remote Run/Stop

**Default Setting:** The RSL510 by default uses the keypad to run and stop, follow instructions below to change to a remote start/stop (contact / switch).

**Instructions to change to remote run/stop:**

- Power down the drive, wait 10 mins.
- Make the connections as shown below in Fig. 2a.
- Verify that all connections are secure, replace covers and power-up the drive.

**Do not apply power until all connections are correct and secure.**

After power-up set parameters **00-02=1** (Run Source from Control Terminals).

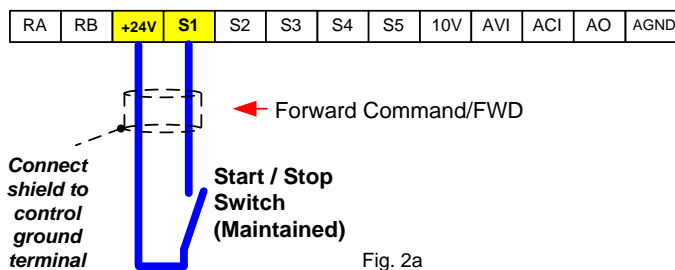

### STEP 6 Using an external potentiometer for speed control

**Default Setting:** The RS510 by default uses the keypad for frequency reference, follow instructions below to use a remote reference (external potentiometer).

**Instructions to change to remote reference:**

- Power down the drive, wait 10 mins.
- Make the connections as shown below in Fig. 2b.
- Verify that all connections are secure then power-up the drive.

**Do not apply power until all connections are correct and secure.**

After power-up set parameter **00-05=2** (Speed Reference from Control Terminals).

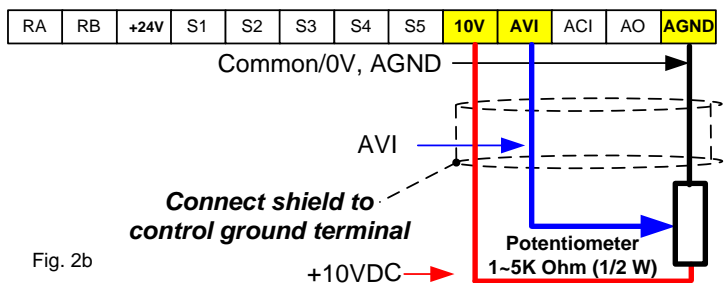

### STEP 7 Frequently Used Parameters

#### Motor Nameplate Data (Parameter 02-01)

The motor rated current is set at the factory based on the inverter model. Enter the motor rated current from the motor nameplate if it does not match the value shown in parameter 02-01.

**Setting range:** Varies by model.

#### Using Keypad Potentiometer (Parameter 00-05)

To use the potentiometer on the keypad set parameter 00-05 to 1.

#### Acceleration and Deceleration Time (Parameter 00-14, 00-15)

Acceleration and Deceleration times directly control the system dynamic response. In general, the longer the acceleration and deceleration time, the slower the system response, and the shorter time, the faster the response. An excessive amount of time can result in sluggish system performance while too short of a time may result in system instability.

The default values suggested normally result in good system performance for the majority of general purpose applications. If the values need to be adjusted, caution should be exercised, and the changes should be in small increments to avoid system instability.

#### 00-14 Acceleration time 1

#### 00-15 Deceleration time 1

These parameters set the acceleration and deceleration times of the output frequency from 0 to maximum frequency and from maximum frequency to 0.

#### Factory Reset (Parameter 13-08)

To reset all parameters back to factory default set parameter 13-08 to 1250 for 50hz 230V/400V and 1360 for 60hz 230V/400V

For the complete RS510 parameter listing and descriptions, refer to the Instruction manual.