



INSTRUCTION MANUAL

IPM 3600N

3 Phase Power Analyser

EN

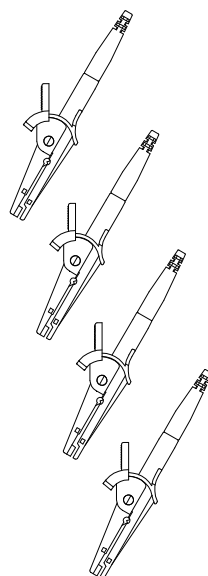
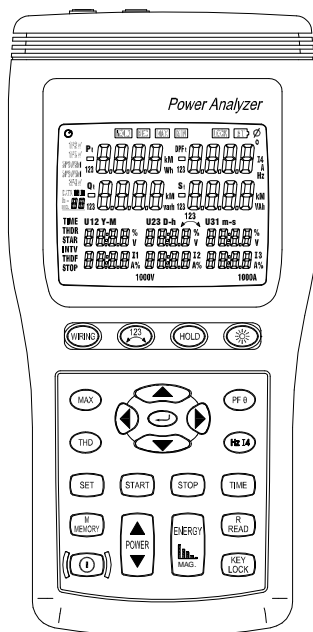
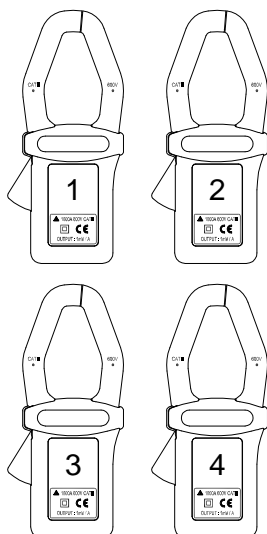







CONTENTS

Title	Page
I. SAFETY INFORMATION	1
II. INTRODUCTION	3
III. SPECIFICATIONS	4
3-1 Environmental Conditions	4
3-2 Safety Specifications	4
3-3 General Specifications.....	5
3-4 Electrical Specification.....	5
IV. PARTS & CONTROLS	9
4-1 Description of Parts & Control keys.....	9
4-2 Description of Display.....	13
V. OPERATING INSTRUCTIONS	16
5-1 ICA 3600N AC Current Probe Connection	16
5-2 Single-Phase 2-Wire (1P2W) Power System Measurement.....	18
5-3 Single-Phase 3-Wire (1P3W) Power System Measurement.....	20
5-4 Three-Phase 3-Wire (3P3W2M) Power System Measurement	22
5-5 Three-Phase 3-Wire (3P3W3M) Power System Measurement	25
5-6 Three-Phase 4-Wire (3P4W) Power System Measurement	27
5-7 Single Phase Current Measurement	29
5-8 Manual Data Memory and Read Function Operation.....	30
5-9 Auto Data logging Function Operation	30
5-10 Phase Sequence Measurement.....	31
5-11 Voltage, Current Waveform and Harmonic Analyzer	33
5-12 Enable Auto Power Off Function	33
VI. MAINTENANCE	34
6-1 General Maintenance	34
6-2 Battery Replacement.....	34
VII. SOFTWARE INSTALLATION AND OPERATION	35

I. SAFETY INFORMATION

The following symbols may appear on the instrument and in this instruction manual:

	Caution refer to this manual before using the instrument. This mark indicates explanation, which is particularly important that the user should read before using the instrument.
	Risk of electric shock
	Instrument is protected by double insulation or reinforced insulation.
	Conforms to relevant EU directives
	Dispose of in accordance with local regulations.

Safety Information

Read and understand this instruction manual completely before using this instrument. Failure to observe the warnings and cautions in this instruction manual may result in injury, death or damage to the instrument and other equipment or property.

If this instrument is used in a manner not specified in these instructions, the protection provided by the instrument may be impaired

DANGER

- Do not store or use the instrument where it will be exposed to direct sunlight, high temperature, high humidity, or condensation
- The instrument is designed for indoor use and can be safely used at temperatures ranging from 0°C to 40°C
- To prevent electric shock, do not allow the instrument to come into contact with water, do not use in damp conditions and do not use the unit with wet hands
- Do not use the instrument in hazardous areas or around explosive or corrosive gases or vapours
- Examine the instrument and probes before use, do not use them if they are damaged
- Do not apply more than the rated voltage, as marked on the instrument and probes, between terminals or between any terminal and earth ground
- To prevent electric shock, de-energise power systems before making connections whenever possible
- Whenever possible, make connections to the output side of a circuit breaker to provide better short circuit protection.
- Use caution with voltages above 30 Vac rms, 42 Vac peak, or 60 Vdc. These voltages pose a shock hazard
- Use extreme caution when working around bare conductors or bus bars. Accidental contact with the conductor could result in electric shock.
- Wear suitable personal protective equipment when working around or near hazardous live conductors which could be accessible

 WARNING

- Do not hold the test leads or probes beyond the finger guards or tactile barriers
- Remove all probes, test leads and accessories that are not required for the test
- Always use proper terminals, switch position, and range for measurements
- Verify the instrument is operating correctly by measuring a known voltage before use. If in doubt, have the instrument serviced
- To avoid false readings that can lead to electric shock and injury, replace battery as soon as the low battery indicator “” appears
- Follow all legal requirements
- Obey posted instructions
- Never assume that a circuit is de-energized, check it first
- Always set up the measurement first, then connect the test leads and probes to the instrument before connecting to the circuit under test
- Connect the ground lead first, then the voltage leads and the current probe, Disconnect in the reverse order
- Route all test leads carefully
- Remove test leads from instrument before opening the battery door or instrument case

 CAUTION: The measurement inputs U1, U2 and U3 are not isolated from each other, input N is the common reference point. Connecting either U1, U2 or U3 to the circuit means that the others are also live and therefore a danger of electric shock is present. To avoid electrical shock, connect only the probes and test leads required for the test.

II. INTRODUCTION

The IPM 3600N is a 3 phase power analyser for portable measurement within public mains supplies.

The analyzer can be used to analyse and trouble shoot power quality issues, improve power efficiency, manage energy costs, analyze harmonics, optimize power system performance, improve power quality and analyze system data to design optimal upgrades.

Features

- 10 display LCD screen, capable of showing many power quality parameters at the same time.
- 4 current probes included for measuring 3 phase and neutral line current.
- Measures single-phase 2-wire, single-phase 3-wire, three-phase 3-wire and three-phase 4-wire systems.
- All true-RMS sensing, V, A, KW, KVAR, KVA, PF, θ , Hz, KWh, KVARh and KVAh measurements.
- Phase sequence indicator function.
- Backlight display function.
- Manual Data Memory and Read (50 sets).
- Data logging (micro SD CARD 4GB).
- **USB** optical PC interface with three phase voltage / current waveform display and harmonic analysis.

Supplied accessories

- **ICA 3600N AC current probe x 4**

Category Rating: CAT III 600V per IEC61010-1, Pollution Degree2.

 : IEC 61010-1 2nd Edition and IEC61010-2-032

Input : AC 1000A maximum.

Output : 0.35mV/A

- **Voltage test lead x 4**

Model no : TL 202I

Manufacturer : Hong Kai Co., Ltd.

Category Rating : CAT III, 1000V AC 10A Max.

- **Alligator clip x 4**

Model no : FC-A26

Manufacturer : Fu Chyi Enterprise CO., Ltd.

Category Rating : CAT III, 1000V AC 10A Max.

- AC Adaptor (IN-OUT Isolated type, Input 230V AC 50Hz)

Model : MWD48-1200300GS

Input : 230V AC 50Hz

Output : 12V DC 300mA

Manufacturer : MAW WOEI Enterprise CO., Ltd.



- Battery 1.5V "AA" x 8
- Instruction manual x 1
- PC software CD-R x 1
- Carrying case x 1
- Optical USB interface x 1

III. SPECIFICATIONS

3-1 Environmental Conditions

- Altitude up to 2000 metres
- Indoor use only
- Ambient operating temperature: 0 to 40°C
- Operating humidity : Max 80%RH \leq 31°C decrease linearly to 50% relative humidity at 40°C (non-condensing).
- Storage temperature and humidity : -10 to 60°C R.H. < 70% non-condensing.

3-2 Safety Specifications

IPM 3600N Power Analyser

Category Rating : CAT III 1000V per IEC 61010-1

Pollution Degree 2

CE : IEC 61010-1 2nd Edition

ICA 3600N AC current probes:

Current Clamps, model ICA 3600N, to be used only with the Three-Phase power analyzer, model IPM 3600N.

Category Rating: CAT III 600V per IEC61010-1,

Pollution Degree2.

CE : IEC 61010-1 2nd Edition and IEC61010-2-032

Input : AC 1000A maximum.

Output : 0.35mV/A

Voltage test leads:

Category Rating : CAT III, 1000V, AC 10A Max.

Alligator clip:

Category Rating : CAT III, 1000V, AC 10A Max.

Category definitions

Measurement Category	Application
I	Measurements on circuits not directly connected to mains. Examples include: Measurements on battery powered equipment and specially protected (internal) mains-derived circuits.
II	Measurements on circuits directly connected to the low voltage installation. Examples include: Household appliances, portable tools and similar equipment.
III	Measurements performed in the building installation. Examples include measurements on distribution boards, junction boxes, socket-outlets and wiring and cables in the fixed installation.
IV	Measurements performed at the source of the low-voltage installation. Examples include measurements on primary over current protection devices and electricity meters

3-3 General Specifications

- Maximum voltage between voltage input terminals and earth ground : 1000 Vrms
- Maximum rated working voltage for current input : 0.35 Vrms
- Maximum current for current probe : 1000 Arms
- Numerical display : 10 display 4 digit LCD maximum reading 9999.
- Battery life : approx. 50 hours.
- Auto power off : approx. 30 minutes.
- Low battery indication : The “**BT**” symbol is displayed when the battery voltage drops below the operating voltage.
- Backlight display time : Auto off approx. 30 seconds.
- Sampling rate : Approx. 1 time per 2 seconds (Digital display).
- Harmonic analyzer : 1 ~ 63th order.
- Manual data memory and read capacity: 50 sets.
- Data logger capacity: micro SD CARD 4GB (Maximum 99 blocks).
- Current probe jaw opening diameter : Cables ϕ 40mm.
- Storage temperature and humidity : -10 to 60°C R.H. < 70% non-condensing.
- Dimensions :
Instrument: 235x117x54 mm.
Current probe: 193x88x40 mm.
- Weight :
Instrument including battery: ~ 730g
Current probe: ~ 333g

3-4 Electrical Specification

Accuracy : \pm (% of reading + number of digits) at 23°C \pm 5°C \leq 80%RH

Temperature coefficient : 0.1 \pm (specified accuracy) / °C (<18 or >28°C)

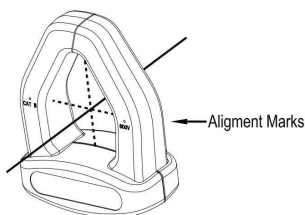

1. Position the conductor within the jaws at the intersection of the indicated marks as much as possible in order to meet this meter's accuracy.
2. If the conductor is positioned elsewhere within the jaws, the maximum additional error is 1.5 percent.

Figure 1. Current Probe Positional Error

AC Voltage Trms measurement (Vrms) :

Range	Resolution	Accuracy	Input impedance	Overload protection	Nominal power system frequency
10 to 999.9V	0.1V	$\pm(0.3\%rdg\pm 10dgts)$	2M Ω	1000Vrms	50Hz

- Display item : RMS voltage value for each channel.

□ AC Current Trms Measurement (Arms) :

Range	Resolution	Accuracy (including current probe)	Current probe output	Overload protection	Nominal power system frequency
10 to 299.9A	0.1A	$\pm 0.5\% \text{rdg} \pm 15 \text{dpts}$	0.35mV/A	1000Arms	50Hz
300 to 999.9A		$\pm 1.2\% \text{rdg} \pm 15 \text{dpts}$			

- Display item : RMS current value for each channel.

□ Active Power measurement P (KW) :

Range	Resolution	Accuracy
0.1 to 999.9KW	0.1KW	$\pm 1.0\% \text{rdg} \pm 20 \text{dpts}$ (10 to 299.9A) $\pm 1.5\% \text{rdg} \pm 20 \text{dpts}$ (300 to 999.9A)

- Display items : Active power of each channel and its sum of multiple channels.
- Polarity display : For influx (consumption) No symbol, For outflow (regenerative) “ - ”.

□ Apparent Power measurement S (KVA) :

Range	Resolution	Accuracy
0.1 to 999.9KVA	0.1KVA	$\pm 1.0\% \text{rdg} \pm 20 \text{dpts}$ (10 to 299.9A) $\pm 1.5\% \text{rdg} \pm 20 \text{dpts}$ (300 to 999.9A)

- Measurement method : Calculated from RMS voltage U and RMS current I.
- Display item : Apparent power of each channel and its sum of multiple channels.
- Polarity display : No polarity.

□ Reactive Power measurement Q (KVAR) :

Range	Resolution	Accuracy
0.1 to 999.9KVAR	0.1KVAR	$\pm 1.0\% \text{rdg} \pm 20 \text{dpts}$ (10 to 299.9A) $\pm 1.5\% \text{rdg} \pm 20 \text{dpts}$ (300 to 999.9A)

- Measurement method : Calculated from apparent power S and active power P,
$$Q = \sqrt{S^2 - P^2}$$
- Display item : Reactive power of each channel and its sum of multiple channels.
- Polarity display : For phase lag : No symbol.
For lead phase : “ - ”

□ Power Factor measurement (COS ϕ) :

Range	Resolution	Calculated Accuracy
-1 to +1	0.001	$\pm 10 \text{dgt}$

- Measurement method : Calculated from apparent power S and active power P,
$$\text{PF} = \text{COS}\phi = \frac{P}{S}$$
- Display item : Power factor of each channel and its sum of multiple channels.

□ Phase angle measurement (ϕ) :

Range	Resolution	Calculated Accuracy
0.1° to +180°, 0.1° to -180°	0.1°	±15dgt



- Measurement method : Calculated from power factor $\text{COS}\phi$, $\phi = \text{COS}^{-1}\text{PF}$.
- Display item : Phase angle of each channel and its sum of multiple channels.
- Polarity display :
For phase lag : No symbol
For phase lead : “-”.

□ Frequency measurement (Hz) :

Range	Resolution	Accuracy	Measurement source
50Hz	0.1Hz	±0.1%rdg±2dgt	Voltage U1 > 50V

- Measurable input range : > 50V

□ Three Phase Sequence Detection :

Input voltage range	Normal phase indication	Reverse phase indication	Measurement source
3P > 50V to 1000V	123 	123 	U1, U2 and U3

□ Active Power Energy measurement (kWh) :

Range	Resolution	Active power accuracy	Timer interval	Timer Accuracy
0.001 to 9.999KWh	0.001KWh	±1.0%rdg±20dgts (10 to 299.9A)	1 sec	±50ppm (25°C)
0.01 to 99.99KWh	0.01KWh			
0.1 to 999.9KWh	0.1KWh			
0.001 to 9.999MWh	0.001MWh	±1.5%rdg±20dgts (300 to 999.9A)		
0.01 to 30.59MWh	0.01MWh			

- Measurement display : Display all active power consumption energy (sum of absolute values).

□ Apparent Power Energy measurement (kVAh) :

Range	Resolution	Apparent power accuracy	Timer interval	Timer Accuracy
0.001 to 9.999kVAh	0.001kVAh	±1.0%rdg±20dgts (10 to 299.9A)	1 sec	±50ppm (25°C, 77°F)
0.01 to 99.99kVAh	0.01kVAh			
0.1 to 999.9kVAh	0.1kVAh			
0.001 to 9.999MVAh	0.001MVAh	±1.5%rdg±20dgts (300 to 999.9A)		
0.01 to 30.59MVAh	0.01MVAh			

- Measurement display : Display all apparent power energy (sum of absolute values).

**☐ Reactive Power Energy measurement (kVARh) :**

Range	Resolution	Reactive power accuracy	Timer interval	Timer Accuracy
0.001 to 9.999kVARh	0.001kVARh	$\pm 1.0\%rdg \pm 20dgts$ (10 to 299.9A)	1 sec	$\pm 50ppm$ (25°C, 77°F)
0.01 to 99.99kVARh	0.01kVARh			
0.1 to 999.9kVARh	0.1kVARh			
0.001 to 9.999MVARh	0.001MVARh	$\pm 1.5\%rdg \pm 20dgts$ (300 to 999.9A)		
0.01 to 30.59MVARh	0.01MVARh			

- Measurement display : Display all reactive power consumption (sum of absolute values).

☐ Harmonic measurement

Order	Accuracy	Harmonic Source
1 to 63	$\pm 3\%THD$	U1, U2, U3 > 10V I1, I2, I3 > 10A

☐ Waveform (possible only on a PC via a PC connection)

Select phase L1, L2 or L3.

Select Voltage and current waveform output.

IV. PARTS & CONTROLS

4-1 Description of Parts & Control keys

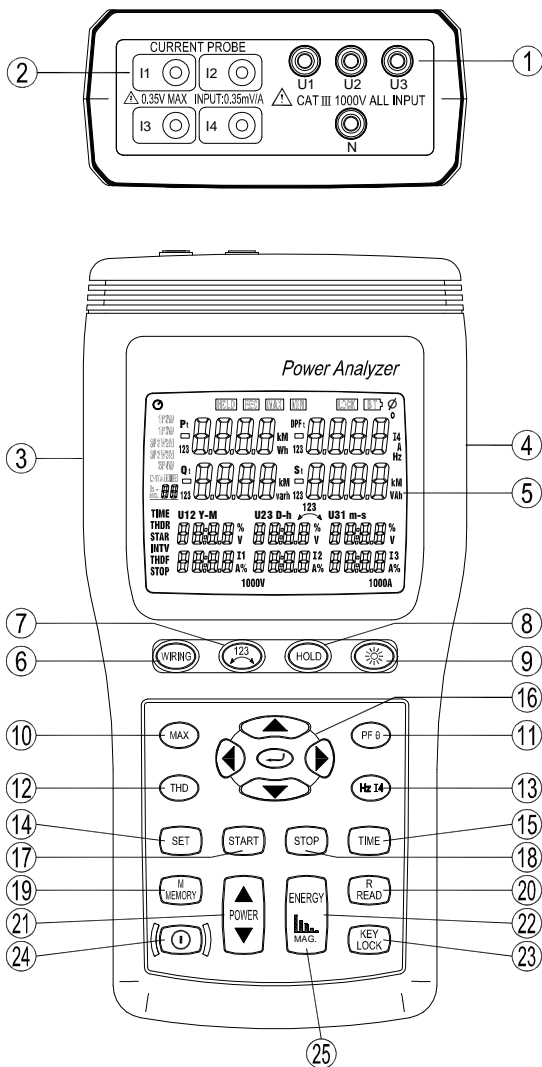



Figure 2. Description of Parts & Control keys

1. **Input for voltage terminals (U1, U2, U3, N).**

Note the 3 inputs are not galvanically isolated, they have the common reference point “N” (neutral).

2. **Input sockets for current probes (I1, I2, I3, I4).**

3. **Plug for external AC adaptor power supply input.**

 **CAUTION:** Use only the mains adaptor supplied with the instrument

4. **Optical USB interface output.**

5. **LCD display.**

6. **WIRING key :** Press “**WIRING**” to select the type of electrical system under test:

- 1P2W -To measure single-phase two-wire power lines
- 1P3W -To measure single-phase three-wire power lines
- 3P3W2M -To measure three-phase, three-wire power lines without neutral, use this when measuring three-phase power with 2-current probe measurement only
- 3P3W3M - To measure three-phase three-wire power line without neutral, using the three power meter method, use this when measuring three-phase power with 3-current probe measurement only
- 3P4W -To measure three-phase four-wire power lines with neutral

7.  **key :** Phase sequence detection function key. In the 3P4W mode, press and hold down this key, it will display phase detection results as follows :

Normal phase 

Reverse phase 

8. **HOLD key :** Data hold function key, press “**HOLD**” key to hold data, the “**HOLD**” symbol is displayed, press “**HOLD**” key again to exit Hold function.

9.  **key :** Backlight function key, press “” key to turn on and off the backlight. The backlight will switch off automatically after 30 seconds.

10. **MAX key:** Active power (P), reactive power (Q), and apparent power (S) Maximum / Minimum recording measurement.

① In the power measurement screen mode, press ◀ or ▶ key to select (P1, Q1, S1), (P2, Q2, S2), (P3, Q3, S3) or (Pt, Qt, St) which one measured value to do the maximum/minimum recording measurement.

② Press “**MAX**” key to enter this mode, the “**REC**” mark is displayed.

③ Press “**MAX**” key to cycle through the

a). Maximum reading the “**REC MAX**” mark is displayed.

Press ▲ key to cycle through the

Maximum reading for Active power (“P” mark is blinking) with its Q, S, V, A reading and its PF, θ , Hz, I4 reading by press “**PFO**” and “**Hz I4**” keys.

Maximum reading for Reactive power (“Q” mark is blinking) with its P, S, V, A reading and its PF, Θ , Hz, I4 reading by press “**PF Θ** ” and “**Hz I4**” keys.

Maximum reading for Apparent power (“S” mark is blinking) with its P, Q, V, A reading and its PF, Θ , Hz, I4 reading by press “**PF Θ** ” and “**Hz I4**” keys.

- b). Minimum reading, the “**REC MIN**” mark is displayed.

Press **▲** key to cycle through the

Minimum reading for Active power (“P” mark is blinking) with its Q, S, V, A reading and its PF, Θ , Hz, I4 reading by press “**PF Θ** ” and “**Hz I4**” keys.

Minimum reading for Reactive power (“Q” mark is blinking) with its P, S, V, A reading and its PF, Θ , Hz, I4 reading by press “**PF Θ** ” and “**Hz I4**” keys.

Minimum reading for Apparent power (“S” mark is blinking) with its P, Q, V, A reading and its PF, Θ , Hz, I4 reading by press “**PF Θ** ” and “**Hz I4**” keys.

- c). Current reading, the “**REC**” mark is displayed.

- ④ Press “**MAX**” key for 3 seconds to exit this mode.

11. **PF Θ key** : Display measured power factor or phase angle value control key, the “PF” or “ ϕ ” symbol is displayed.

12. **THD key**: Display measured voltage or current THDF, THDR value control key.

THDF: Total Harmonic Distortion of a waveform is compared to its Fundamental.

THDR: Total Harmonic Distortion of a waveform is compared to the waveforms rms value.

- ① Press “**THD**” key to enter the Voltage U1, U2 and U3 THDR and THDF measurement mode, the “THDR” and “THDF” marks are displayed.
 ② Press “**THD**” key again to enter the Current I1, I2 and I3 measurement mode, the “THDR” and “THDF” marks are displayed.
 ③ Press “**THD**” key again to exit this mode.

13. **Hz I4 key** : Display measured frequency or I4 current probe value control key, the “Hz” or “I4” symbol is displayed.

14. **SET key** : Setting current date and time function key, press “**SET**” key to enter current time setting mode and interval time setting mode for auto data logging use.







- 15 **TIME key** : Display current date and time control key, press and hold down “**TIME**” key to display the current data and time.

Press and hold down “**TIME**” key then press **ⓘ** key turn on the meter, the “**⌚**” mark appear, enter into auto power off function.

16. **▲▼◀▶↵** keys :

- ① In the harmonic measurement mode, press **↵** key to select voltage or current harmonic source. Press **◀** or **▶** key to select which source to be displayed. Press **▲** or **▼** key to select harmonic order.
 ② Set current date and time, or recall manual data memory control keys

17. **START key** : Start auto data logging function.

18. **STOP key** : Stop auto data logging function. Press “**START**” key to resume recording in current data sets.
19. **MEMORY key** : Manual data memory control key. Press “**MEMORY**” key each time to store one set of current display reading into the memory, the “**M**” symbol and the memory address number is displayed, total memory size is 50 sets.
20. **READ key** : Read manual memory data control key.
21. **▲POWER▼ key** : Display measured power value control key, the Pt123, Qt123 and St123 symbols will be displayed in cycles.
22. **ENERGY key** : Display total integrated power energy value control key.
23. **KEY Lock key** : Lock all the functions key, except  and  keys, the “**LOCK**” symbol is displayed.
24.  **key** : Power on-off control key.
25.  **MAG. key**: Harmonic measurement control key.
- ① Press “ **MAG.**” key to enter the voltage and current waveform harmonic measurement mode, the harmonic order number “Hd:XX” and its measured value (V or A), harmonic ratio (%), P, Q, S, PF values are displayed.
 - ② Press **▲** or **▼** key to scroll the harmonic order from “Hd:01” to “Hd:63”.
 - ③ Press **↵** key to scroll the voltage or current harmonic for display.
 - ④ Press **◀** or **▶** key to scroll the U1, U2, U3 or I1, I2, I3 for display.
 - ⑤ Press “ **MAG.**” key again to exit this mode.

4-2 Description of Display

The multi-line display shows the currently measured primary values.

The display format, symbols and the units (V, kV, A, kA, W, kW, MW etc...) are automatically displayed to match the selected values and functions and mode of operation.

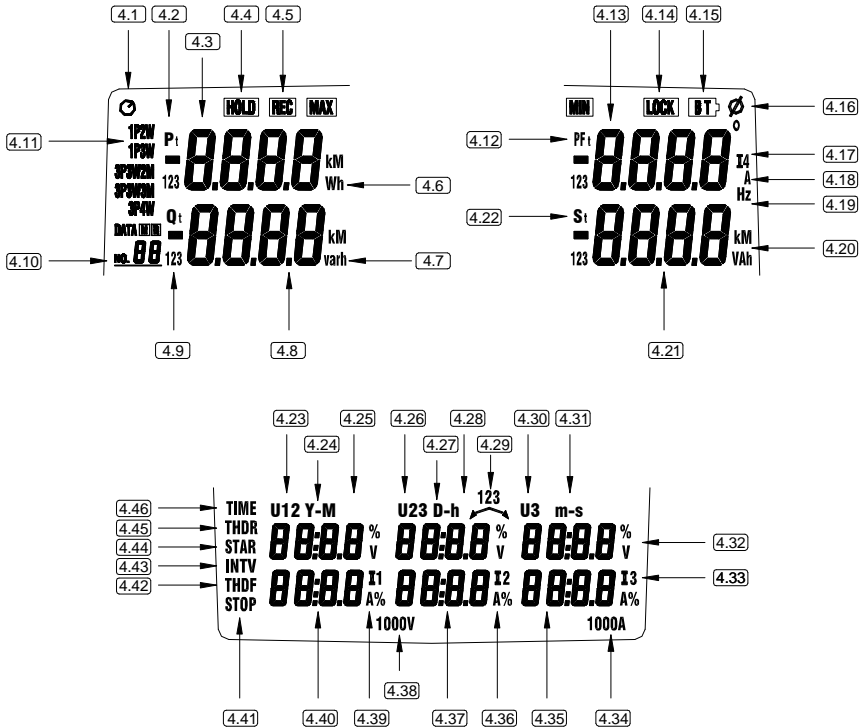



Figure 3. Display Layout

4.1	⊙ : Auto power off indication.
4.2	P : Harmonic active power measured display indicator. P1 : Phase 1 active power measured display indicator. P2 : Phase 2 active power measured display indicator. P3 : Phase 3 active power measured display indicator. Pt : Total active power measured display indicator and total active energy measured display indicator.
4.3	Display value of Active Power
4.4	HOLD : Display hold mode.
4.5	REC MAX : Maximum recorded reading. REC MIN : Minimum recorded reading. REC : Recording mode indication and current reading.
4.6	KW : Active Power Unit: or KWh , MWh , active energy unit
4.7	Kvar : Reactive Power Unit or Kvarh , Mvarh reactive energy unit
4.8	Display of reactive Power
4.9	Q : Harmonic reactive power measured display indicator. Q1 : Phase 1 reactive power measured display indicator. Q2 : Phase 2 reactive power measured display indicator. Q3 : Phase 3 reactive power measured display indicator. Qt : Total reactive power measured display indicator and total reactive energy measured display indicator.
4.10	DATA No.xx : Last manual datalogged memory address number indication (01~50). M : Manual datalogged indication, M displays one time store one sets data into the memory. R No.xx : Recall manual datalogged address number indication, the memory data displayed for read. DATA M xx : Auto datalogging indication, M disappears one time store one sets data into the memory . 01 ~ 99 : Maximum 99 memory blocks can be use. FULL : Memory full indication, if exceed 99 memory blocks or micro SD CARD is full used.
4.11	1P2W : Measure single-phase two-wire power line indicator. 1P3W : Measure single-phase three-wire power line indicator. 3P3W2M : Measure three-phase three-wire power line indicator. 3P3W3M : Measure three-phase three-wire power line using 3 power meter indicator. 3P4W : Measure three-phase four-wire power line indicator.
4.12	PF : Harmonic power factor measured display. PF1 : Phase 1 power factor measured display. PF2 : Phase 2 power factor measured display. PF3 : Phase 3 power factor measured display. PFt : Total power factor measured display.
4.13	Display value for Power Factor, Frequency & I4 current
4.14	LOCK : Keyboard lock indicator.
4.15	BT : Low battery indicator.

4.16	° : Phase angle unit ϕ : Phase angle display
4.17	Indicates current measurement from input "I4"
4.18	A : Unit of current
4.19	Hz : Unit of frequency
4.20	KVA : Apparent power unit or KVAh, MVAh : Apparent energy unit.
4.21	Display value of apparent power
4.22	S : Harmonic apparent power measured display indicator. S1 : Phase 1 apparent power measured display indicator. S2 : Phase 2 apparent power measured display indicator. S3 : Phase 3 apparent power measured display indicator. St : Total apparent power measured display indicator and total apparent energy measured display indicator.
4.23	U1 : Indicates the display of voltage on phase 1(U1), THDR %, THDF % or Harmonic.
4.24	Y-M : Year and Month display indicator
4.25	Display of Voltage, Date (Year: Month), THDR % or Harmonic order number (Hd: 01 ~ Hd: 63)
4.26	U2 : Indicates the display of voltage on phase 2(U2), THDR %, THDF % or Harmonic.
4.27	D-h : Day and hour display indicator
4.28	Display of Voltage or Date (Day: hour) or THDR%
4.29	123  Display of the rotary field direction
4.30	U3 : indicates display of voltage on phase 3, THDR%, THDF% or Harmonic
4.31	m-s : minutes and seconds display indicator
4.32	Display of Voltage, Time (minutes: second) or THDR%
4.33	A, I3, % : units and indicator for phase 3 current, THDR%, THDF% or Harmonic
4.34	1000A : Current range indicator
4.35	Display of current, time or THDF%
4.36	A, I2, % : units and indicator for phase 2 current, THDR%, THDF% or Harmonic
4.37	Display of current, date/time or THDF%
4.38	1000V : Voltage range indicator
4.39	A, I1, % : units and indicator for phase 1 current, THDR%, THDF% or Harmonic
4.40	Display of current, date or THDF%
4.41	STOP : Indicates the stop time for energy calculation
4.42	THDF : Voltage or current Total Harmonic Distortion of a waveform to its Fundamental indicator.
4.43	INTV : Indicates the Auto data logging interval time setting
4.44	STAR : Indicates the start time for energy calculation
4.45	THDR : Voltage or current Total Harmonic Distortion of a waveform to the waveform RMS value indication.
4.46	TIME : Current data and time indicator

V. OPERATING INSTRUCTIONS

DANGER

- Voltage input connectors U1 to, U2 & U3 are not galvanically isolated, they have the common reference point “N” (neutral)
- Only connect the necessary number of test leads and probes for the test.

WARNING

- Always set up the measurement first, then connect the test leads and probes to the instrument before connecting to the circuit under test
- Connect the Neutral lead first, then the voltage leads and the current probe, Disconnect in the reverse order.
- Remove all test leads and probes that are not in use.

CAUTION

- Where possible, isolate the power to the electrical circuit to be tested before connecting the voltage test leads and current probes.

5-1 ICA 3600N AC Current Probe Connection

Safety Information

- Read the operating instructions before using and follow all safety instructions.
- Use the current probe only as specified in the operating instructions, otherwise the instruments safety features may not protect you.
- Adhere to local and national safety codes. Personal protective equipment must be used to prevent shock and arc blast injury where hazardous live conductors are exposed.
- Do not hold the current probe anywhere beyond the tactile barrier, see Figure 4. ICA 3600N Current Probe
- Before each use, inspect the current probes. Look for cracks or missing portions of the clamp housing or output cable insulation. Also look for loose or weakened components. Pay particular attention to the insulation surrounding the jaws.
- Do not use damaged current probes.
- Never use the current probes on a circuit with voltages higher than 600V CAT III.
- Use extreme caution when working around bare conductor or bus bars, contact with the conductor could result in electric shock.
- Use caution with voltages above 30 Vac rms, 42 Vac peak, or 60 Vdc. These voltages pose a shock hazard
- Use only the current probes supplied with the analyser.

 **CAUTION** : Ensure the current probe is connected to the instrument before clamping around a live conductor. Open current probe outputs can induce a high voltage in the outputs that can be dangerous to the user and can lead to destruction of the current probe.

(See Figure 1. Current Probe Positional Error and Figure 4. ICA 3600N Current Probe)

1. Connect the current probe to the instrument.
2. Connect the current probe jaws around the conductor to be measured
 - ① Centre the conductor inside the current probe jaw
 - ② Make sure the probe is perpendicular to the conductor
 - ③ Ensure the arrow on the top of the probe faces towards the load of the circuit
 - ④ For optimal reading, ensure that the conductor is positioned between the alignment marks on the jaws of the current probe
 - ⑤ Avoid taking measurements close to other current carrying conductors

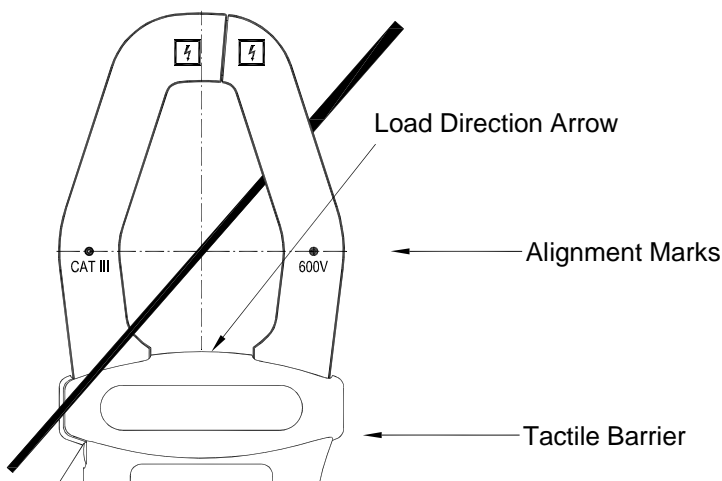

Figure 4. ICA 3600N Current Probe

5-2 Single-Phase 2-Wire (1P2W) Power System Measurement

L1 : Phase, N : Neutral, G : Ground, Face the current probe arrows toward the load.

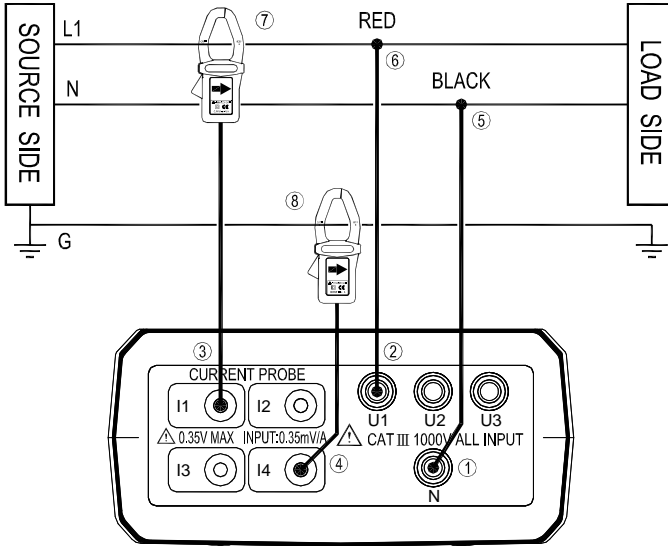

Figure 5. 1P2W Wiring Connection Diagram

Note: U1 must be connected to the voltage source during the measurement of I1 because U1 is the main signal source of the whole instrument measuring system.

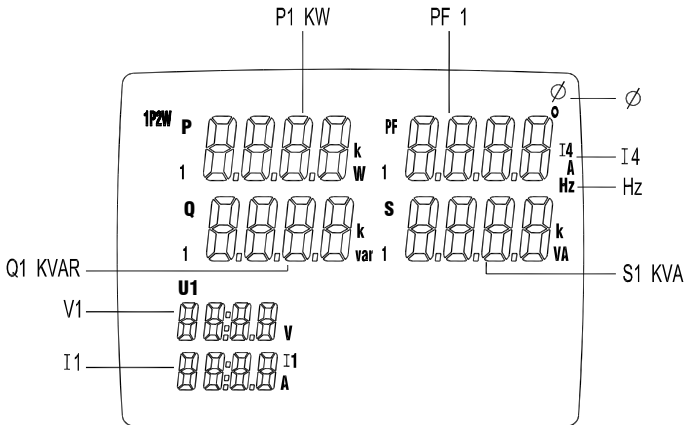



Figure 6. 1P2W General Display

1. Press “**I**” key to turn on the instrument.
2. Press “**WIRING**” key to select the 1P2W electrical system test, the “**1P2W**” symbol will be displayed.
3. Connect the voltage test leads and current probes to the instrument:
 - ① Connect the black voltage test lead to the “N” terminal.
 - ② Connect the red voltage test lead to the “U1” terminal.
 - ③ Connect the I1 current probe to the “I1” socket.
 - ④ To measure ground leakage current, connect the I4 current probe to the “**I4**” socket.
4. Connect the voltage test leads and current probes to the electrical equipment to be tested as shown in Figure 5. 1P2W Wiring Connection Diagram.

⚠ CAUTION: Where possible, isolate the power to the electrical circuit to be tested before connecting the voltage test leads and current probes.

- ⑤ Connect the black voltage test alligator clip to the Neutral Line “N”.
 - ⑥ Connect the red voltage test alligator clip to phase “L1”.
 - ⑦ Clamp the I1 current probe securely around phase “L1”.
 - ⑧ To measure ground leakage current, clamp the I4 current probe securely around the Ground Line “G”.
5. Frequency (Hz), Phase Angle (Θ), Ground Leakage Current (I4) and Power Factor (pF) measurement :
 - ① Press “**PFO**” key to cycle shows the PF and Θ measured values.
 - ② Press “**Hz I4**” key to cycle shows the Hz and I4 measured values.
 6. Voltage and Current THDR THDF measurement:
Please refer to section 4-1-12 “**THD**” key description.
 7. Voltage and Current waveform harmonic measurement:
Please refer to section 4-1-25  “**MAG**.” key description.
 8. Power Maximum/Minimum measurement:
Please refer to section 4-1-10 “**MAX**” key description.
 9. Energy measurement:
 - ① Press “**ENERGY**” key, the “Pt”, “Qt”, “St” and “PFt” or “ ϕ t” symbol are displayed and the starting time of the energy measurement is displayed in the “STAR” line. The energy values and the current time will be displayed during the energy measurement.
 - a). KW displays KWh
 - b). KVAR displays KVARh
 - c). KVA displays KVAh
 - ② Press “**STOP**” key to stop and hold the energy measurements. The “**HOLD**” symbol is displayed and the final calculation time appears in the “STOP” line on the display.
 - ③ Press “**⏏**” key to exit the energy measurement mode and return to normal measurement mode.

5-3 Single-Phase 3-Wire (1P3W) Power System Measurement

L1, L2 : Phase 1, Phase 2, N : Neutral, G : Ground

Face the current probe arrows toward the load

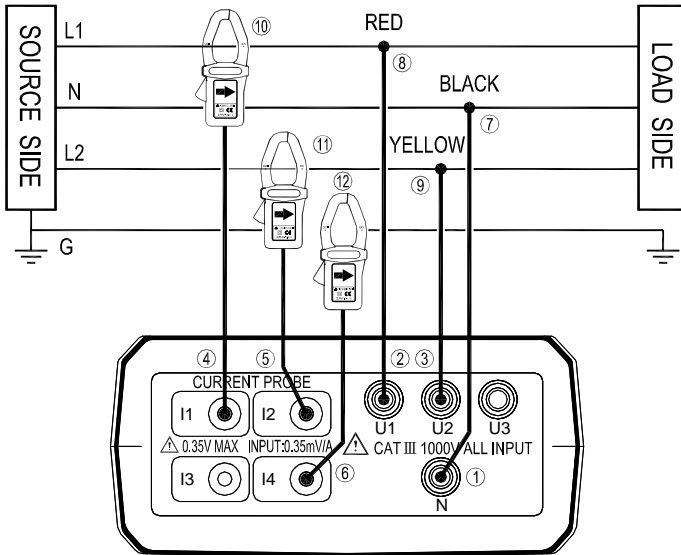

Figure 7. 1P3W Wiring Connection Diagram

Note: U1 must be connected to the voltage source during the measurement of U2, I1 and I2, because U1 is the main signal source of the whole instrument measuring system.

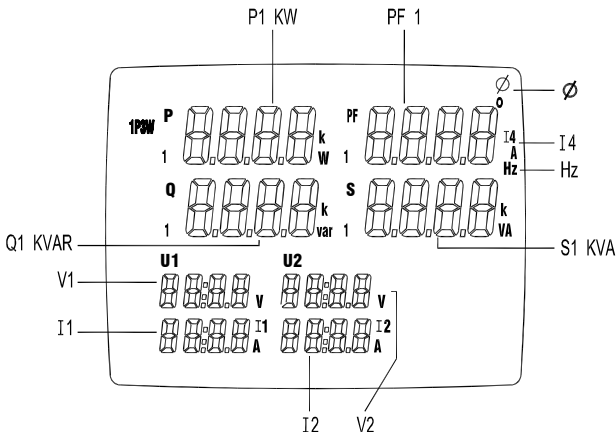



Figure 8. 1P3W General Display

1. Press **I** key to turn on the instrument.
2. Press **“WIRING”** key to select the 1P3W electrical system test, the **“1P3W”** symbol will be displayed.
3. Connect the voltage test leads and current probes to the instrument :
 - ① Connect the black voltage test lead to the “N” terminal.
 - ② Connect the red voltage test lead to the “U1” terminal.
 - ③ Connect the yellow voltage test lead to the “U2” terminal.
 - ④ Connect the I1 current probe to the “I1” socket.
 - ⑤ Connect the I2 current probe to the “I2” socket.
 - ⑥ To measure ground leakage current, connect the I4 current probe output plug to the **“I4”** socket.
4. Connect the voltage test leads and current probes to the electrical equipment to be tested as shown in Figure 7. 1P3W Wiring Connection Diagram.

⚠ CAUTION: Where possible, isolate the power to the electrical circuit to be tested before connecting the voltage test leads and current probes

- ⑦ Connect the black voltage test alligator clip to the neutral conductor “N”.
 - ⑧ Connect the red voltage test alligator clip to Phase 1 “L1”.
 - ⑨ Connect the yellow voltage test alligator clip to Phase 2 “L2”.
 - ⑩ Clamp the I1 current probe securely around Phase 1 “L1”.
 - ⑪ Clamp the I2 current probe securely around Phase 2 “L2”.
 - ⑫ To measure ground leakage current, clamp the I4 current probe securely around the ground line “G”.
5. Press **“▲POWER▼”** key to select between Phase 1 (P1, Q1, S1, PF1), Phase 2 (P2, Q2, S2, PF2) and total (Pt, Qt, St, PFT) measured values.
 6. Frequency (Hz), Phase Angle (Θ), Ground Leakage Current (I4) and Power Factor (pF) measurement:
 - ① Press **“PFO”** key to cycle shows the PF and Θ measured values.
 - ② Press **“Hz I4”** key to cycle shows the Hz and I4 measured values.
 7. Voltage and Current THDR THDF measurement:
Please refer to section 4-1-12 **“THD”** key description.
 8. Voltage and Current waveform harmonic measurement:
Please refer to section 4-1-25  **“MAG.”** key description.
 9. Power Maximum/Minimum measurement:
Please refer to section 4-1-10 **“MAX”** key description.
 10. Energy measurement:
 - ① Press **“ENERGY”** key, the “Pt”, “Qt”, “St” and “PFT” or “ϕt” symbol are displayed and the starting time of the energy measurement is displayed in the “STAR” line. The energy values and the current time will be displayed during the energy measurement.

- a). KW displays KWh
 - b). KVAR displays KVARh
 - c). KVA displays KVAh
- ② Press “STOP” key to stop and hold the energy measurements. The “**HOLD**” symbol is displayed and the final calculation time appears in the “STOP” line on the display.
 - ③ Press “↵” key to exit the energy measurement mode and return to normal measurement mode.

5-4 Three-Phase 3-Wire (3P3W2M) Power System Measurement

Using 2 power meter method

L1, L2, L3 : Phase 1, Phase 2, Phase 3, G : Ground, Face the current probe arrows toward the load

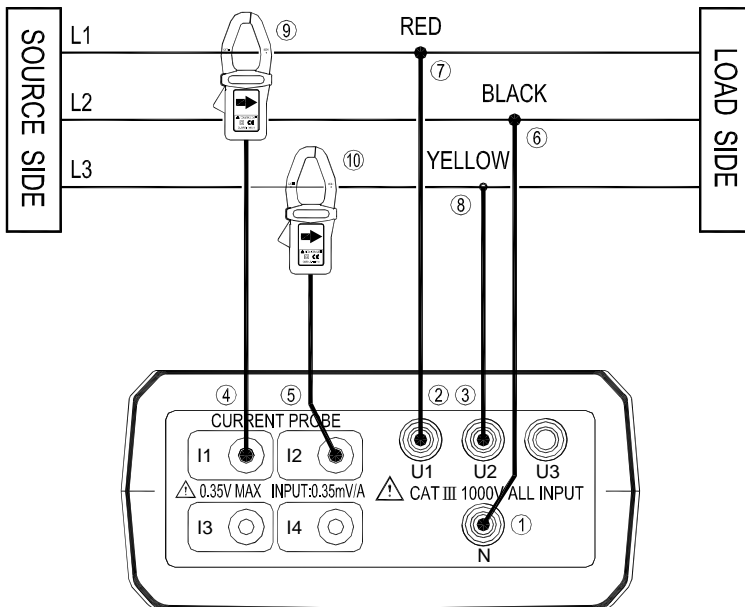

Figure 9. 3P3W2M Wiring Connection Diagram

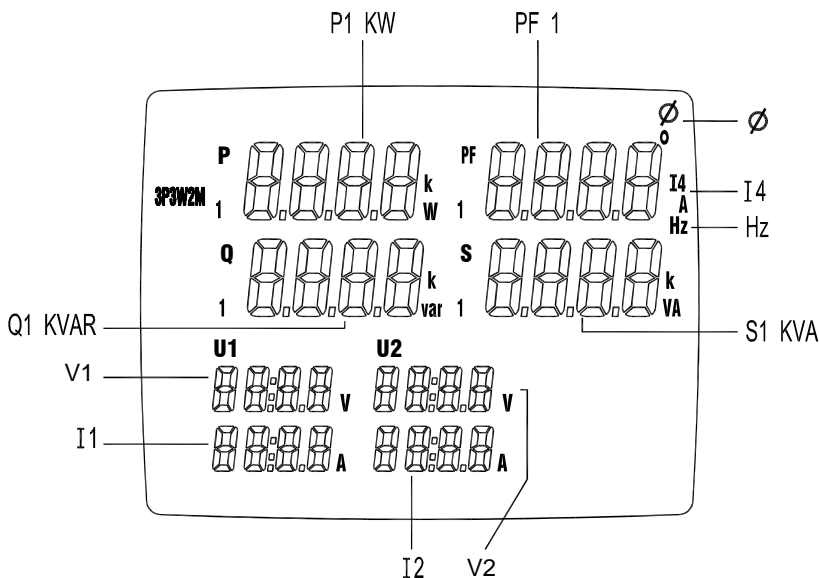



Figure 10. 3P3W2M General Display

1. Press **ⓘ** key to turn on the instrument.
2. Press **"WIRING"** key to select the 3P3W2M electrical system test, the "3P3W2M" symbol will be displayed.
3. Connect the voltage test leads and current probes to the instrument :
 - ① Connect the black voltage test lead to the "N" terminal.
 - ② Connect the red voltage test lead to the "U1" terminal.
 - ③ Connect the yellow voltage test lead to the "U2" terminal.
 - ④ Connect the I1 current probe to the "I1" socket.
 - ⑤ Connect the I2 current probe to the "I2" socket.
4. Connect the voltage test leads and current probes to the electrical equipment to be tested as shown in Figure 9. 3P3W2M Wiring Connection Diagram

⚠ CAUTION: Where possible, isolate the power to the electrical circuit to be tested before connecting the voltage test leads and current probes

- ⑥ Connect the black voltage test alligator to the Phase 2 "L2".
- ⑦ Connect the red voltage test alligator to the Phase 1 "L1".
- ⑧ Connect the yellow voltage test alligator to the Phase 3 "L3".
- ⑨ Clamp the I1 current probe securely around Phase 1 "L1"
- ⑩ Clamp the I2 current probe securely around Phase 3 "L3".

5. Press “▲POWER▼” key to select between Phase 1(P1, Q1, S1, PF1), Phase 2 (P2, Q2, S2, PF2) and total (Pt, Qt, St, PFt) measured values.
6. Frequency (Hz), Phase Angle (Θ) and Power Factor (pF) measurement:
 - ① Press “PFO” key to cycle shows the PF and Θ measured values.
 - ② Press “Hz I4” key to cycle shows the Hz and I4 measured values.
7. Voltage and Current THDR THDF measurement:
Please refer to section 4-1-12 “THD” key description.
8. Voltage and Current waveform harmonic measurement:
Please refer to section 4-1-25 “ MAG.” key description.
9. Power Maximum/Minimum measurement:
Please refer to section 4-1-10 “MAX” key description.
10. Energy measurement:
 - ① Press “ENERGY” key; the “Pt”, “Qt”, “St” and “PFt” or “ ϕ t” symbol are displayed and the starting time of the energy measurement is displayed in the “STAR” line. The energy values and the current time will be displayed during the energy measurement.
 - a). KW displays KWh
 - b). KVAR displays KVARh
 - c). KVA displays KVAh
 - ② Press “STOP” key to stop and hold the energy measurements. The “HOLD” symbol is displayed and the final calculation time appears in the “STOP” line on the display.
 - ③ Press “↵” key to exit the energy measurement mode and return to normal measurement mode.

5-5 Three-Phase 3-Wire (3P3W3M) Power System Measurement

Using 3 power meter method

L1, L2, L3 : Phase 1, Phase 2, Phase 3, G : Ground, Face the current probe arrows toward the load

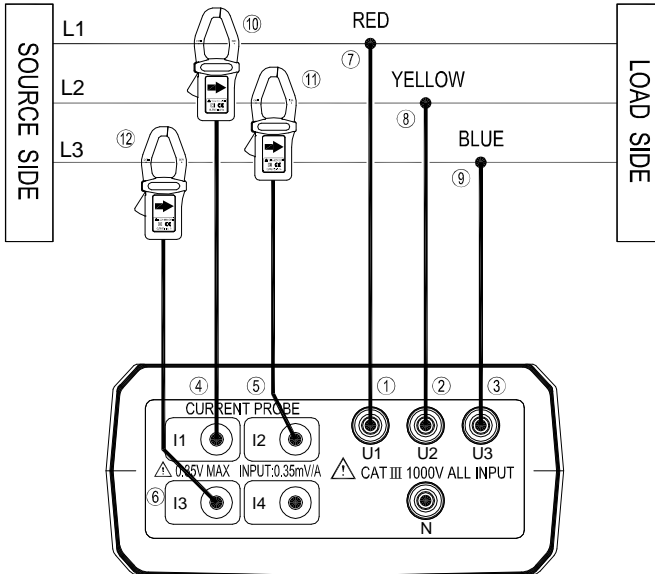

Figure 11. 3P3W3M Wiring Connection Diagram

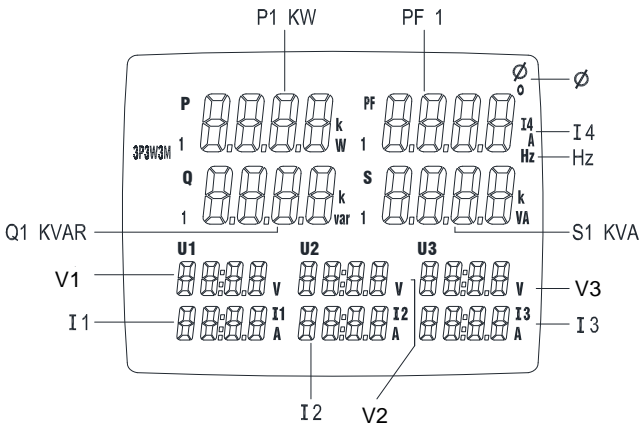



Figure 12. 3P3W3M General Display

1. Press **I** key to turn on the instrument.
2. Press **“WIRING”** key to select the 3P3W3M electrical system test, the “3P3W3M” symbol will be displayed.
3. Connect the voltage test leads and current probes to the instrument :
 - ① Connect the red voltage test lead to the “U1” terminal.
 - ② Connect the yellow voltage test lead to the “U2” terminal.
 - ③ Connect the blue voltage test lead to the “U3” terminal.
 - ④ Connect the I1 current probe to the “I1” socket.
 - ⑤ Connect the I2 current probe to the “I2” socket.
 - ⑥ Connect the I3 current probe to the “I3” socket.
4. Connect the voltage test leads and current probes to the electrical equipment to be tested as shown in Figure 11. 3P3W3M Wiring Connection Diagram

⚠ CAUTION: Where possible, isolate the power to the electrical circuit to be tested before connecting the voltage test leads and current probes

- ⑦ Connect the red voltage test alligator to the Phase 1 “L1”.
 - ⑧ Connect the yellow voltage test alligator to the Phase 2 “L2”.
 - ⑨ Connect the blue voltage test alligator to the Phase 3 “L3”.
 - ⑩ Clamp the I1 current probe securely around Phase 1 “L1”
 - ⑪ Clamp the I2 current probe securely around Phase 2 “L2”.
 - ⑫ Clamp the I2 current probe securely around Phase 3 “L3”.
5. Press **“▲POWER▼”** key to select between Phase 1(P1, Q1, S1, PF1), Phase 2 (P2, Q2, S2, PF2) and total (Pt, Qt, St, PFt) measured values.
 6. Frequency (Hz), Phase Angle (Θ) and Power Factor (pF) measurement:
 - ① Press **“PFO”** key to cycle shows the PF and Θ measured values.
 - ② Press **“Hz I4”** key to cycle shows the Hz and I4 measured values.
 7. Voltage and Current THDR THDF measurement:
Please refer to section 4-1-12 **“THD”** key description.
 8. Voltage and Current waveform harmonic measurement:
Please refer to section 4-1-25 **“ MAG.”** key description.
 9. Power Maximum/Minimum measurement:
Please refer to section 4-1-10 **“MAX”** key description.
 10. Energy measurement:
 - ① Press **“ENERGY”** key; the “Pt”, “Qt”, “St” and “PFt” or “Qt” symbol are displayed and the starting time of the energy measurement is displayed in the “STAR” line. The energy values and the current time will be displayed during the energy measurement.
 - a). KW displays KWh
 - b). KVAR displays KVARh
 - c). KVA displays KVAh
 - ② Press **“STOP”** key to stop and hold the energy measurements. The **“HOLD”** symbol is displayed and the final calculation time appears in the “STOP” line on the display.
 - ③ Press **“J”** key to exit the energy measurement mode and return to normal measurement mode.

5-6 Three-Phase 4-Wire (3P4W) Power System Measurement

L1, L2, L3 : Phase 1, Phase 2, Phase 3, N: Neutral, G : Ground, Face the current probe arrows toward the load

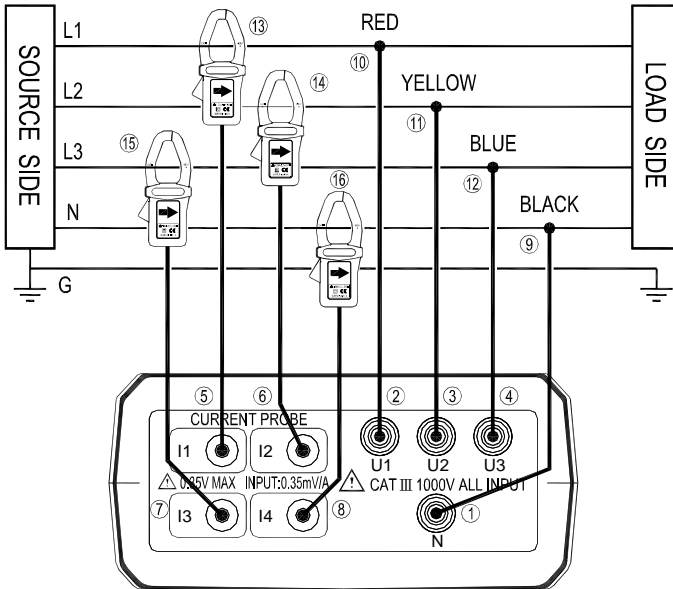

Figure 13. 3P4W Wiring Connection Diagram

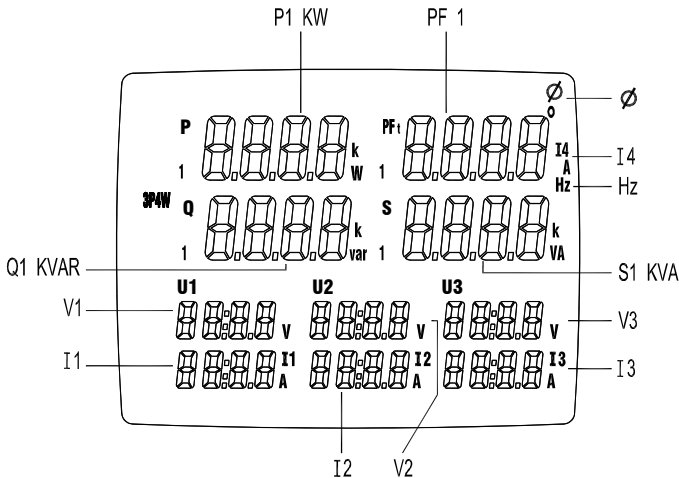





Figure 14. 3P4W General Display

1. Press  key to turn on the instrument.
2. Press **"WIRING"** key to select the 3P4W electrical system test, the "3P4W" symbol will be displayed.
3. Connect the voltage test leads and current probe to the instrument:
 - ① Connect the black voltage test lead to the "N" terminal.
 - ② Connect the red voltage test lead to the "U1" terminal.
 - ③ Connect the yellow voltage test lead to the "U2" terminal.
 - ④ Connect the blue voltage test lead to the "U3" terminal.
 - ⑤ Connect the I1 current probe to the "I1" socket.
 - ⑥ Connect the I2 current probe to the "I2" socket.
 - ⑦ Connect the I3 current probe to the "I3" socket.
 - ⑧ Connect the I4 current probe to the "I4" socket.
4. Connect the voltage test leads and current probes to the electrical equipment to be tested as shown in Figure 11. 3P4W Wiring Connection Diagram.

 **CAUTION:** Where possible, isolate the power to the electrical circuit to be tested before connecting the voltage test leads and current probes.

- ⑨ Connect the black voltage test alligator clip to the neutral conductor "N".
 - ⑩ Connect the red voltage test alligator clip to Phase 1 "L1".
 - ⑪ Connect the yellow voltage test alligator clip to Phase 2 "L2".
 - ⑫ Connect the blue voltage test alligator clip to the Phase 3 "L3".
 - ⑬ Clamp the I1 current probe securely around Phase 1 "L1".
 - ⑭ Clamp the I2 current probe securely around Phase 2 "L2".
 - ⑮ Clamp the I3 current probe securely around Phase 3 "L3".
 - ⑯ Clamp the I4 current probe securely around the neutral conductor "N".
5. Press **"▲POWER▼"** key to select between Phase 1 (P1, Q1, S1, PF1), Phase 2 (P2, Q2, S2, PF2), Phase 3 (P3, Q3, S3, PF3) and total (Pt, Qt, St, PFt) measured values.
 6. Frequency (Hz), Phase Angle (Θ), Neutral Line Current (I4) and Power Factor (pF) measurement:
 - ① Press **"PFO"** key to cycle shows the PF and Θ measured values.
 - ② Press **"Hz I4"** key to cycle shows the Hz and I4 measured values.
 7. Voltage and Current THDR THDF measurement:
Please refer to section 4-1-12 **"THD"** key description.
 8. Voltage and Current waveform harmonic measurement:
Please refer to section 4-1-25  **"MAG."** key description.
 9. Power Maximum/Minimum measurement:
Please refer to section 4-1-10 **"MAX"** key description.

10. Energy measurement:

- ① Press **“ENERGY”** key, the “Pt”, “Qt”, “St” and “Pft” or “oft” symbol are displayed and the starting time of the energy measurement is displayed in the “STAR” line. The energy values and the current time will be displayed during the energy measurement.
 - a). KW displays KWh
 - b). KVAR displays KVARh
 - c). KVA displays KVAh
- ② Press **“STOP”** key to stop and hold the energy measurements. The **“HOLD”** symbol is displayed and the final calculation time appears in the “STOP” line on the display.
- ③ Press **“↓”** key to exit the energy measurement mode and return to normal measurement mode.

5-7 Single Phase Current Measurement

L1, L2, L3 : Phase 1, Phase 2, Phase 3, N: Neutral, G : Ground,  Face the current probe arrows toward the load

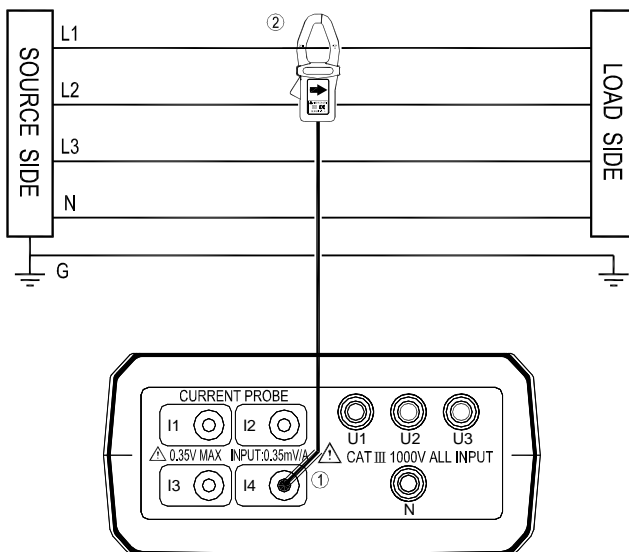



Figure 15. Single Phase Current Measurement

1. Press **“”** key to turn on the instrument.
2. Press **“I4”** key.
3. Connect the I4 current probe to the “I4” socket.
4. Clamp the I4 current probe securely around the conductor to be measured.
5. Read the I4 value, if the measured current value greater than 250A, the display will show the “OL” symbol.

5-8 Manual Data Memory and Read Function Operation

1. Clear memory data :

- ① Press **ⓘ** key to turn off the instrument.
- ② Press and hold down the **"MEMORY"** key then press **ⓘ** key again to turn on the instrument, and to enter clear manual memory data mode, the **"DATA M CLr 1 YES no"** mark is displayed.
- ③ Press **◀** or **▶** key to select **"YES"** or **"no"** then press **↵** key to confirm.
If select **"YES"**, the all manual memorized data is cleared.

2. Store individual measurement data to memory :

- ① Press **"MEMORY"** key once to store one set of displayed data to memory, the **M** symbol displays once and the stored memory address will be displayed.
- ② Maximum store memory capacity size is 50 sets.

3. Read the manually stored data :

- ① Press **"READ"** key to enter the read mode, the **R** symbol is displayed.
- ② Press **▲** and **▼** keys to read the stored data, the data address will be displayed.
- ③ Press **"READ"** key to exit the read mode.

5-9 Auto Data logging Function Operation

1. Clear SD Card memory data:

- ① Press **ⓘ** key to turn off the meter.
- ② Press and hold down the **"MEMORY"** key then press **ⓘ** key again to turn on the meter and to enter clear manual memory data mode, the **"DATA M CLr 1 YES no"** mark is displayed.
- ③ Press **↵** key to enter clear SD Card memory data mode, the **"DATA M CLr 2 YES no"** mark is displayed.
- ④ Press **◀** or **▶** key to select **"YES"** or **"no"** then press **↵** key to confirm.
If select **"YES"**, the all SD Card memorized data is cleared.

2. Store Auto data logging data to memory:

Setting the current time and Auto data logging interval time:

- ① Press **"SET"** key to enter current time setting mode.
- ② Press **▲**, **▼**, **◀** and **▶** keys to set the current YEAR-month, DAY-hour and minute-seconds.
- ③ Press **↵** key to enter auto data logging interval time setting, the **"INTV"** symbol is displayed.
- ④ Press **▲** and **▼** keys to select either 5 seconds, 30 seconds, 1 minute or 2 minute interval time.
- ⑤ Press **↵** key to exit TIME setting mode.

3. Enter Auto data logging mode.

- ① Press **"START"** key to start Auto data logging, **"DATA Mxx"** will be displayed, the **M** symbol, will display each time one set of data is stored into the memory.

- ② Press “**STOP**” key to stop recording data, press “**START**” key to resume recording data, but maximum can be divide to 99 memory blocks, the current block number will be displayed (01 ~ 99).
- ③ When the maximum block or maximum capacity is full, the “**DATA FULL**” symbol will be displayed and data recording is automatically stopped.

4. Download data to PC

Please refer to the software manual (CD-ROM) to download the data.

5-10 Phase Sequence Measurement

L1, L2, L3 : Phase 1, Phase 2, Phase 3, N: Neutral, G : Ground,  Face the current probe arrows toward the load

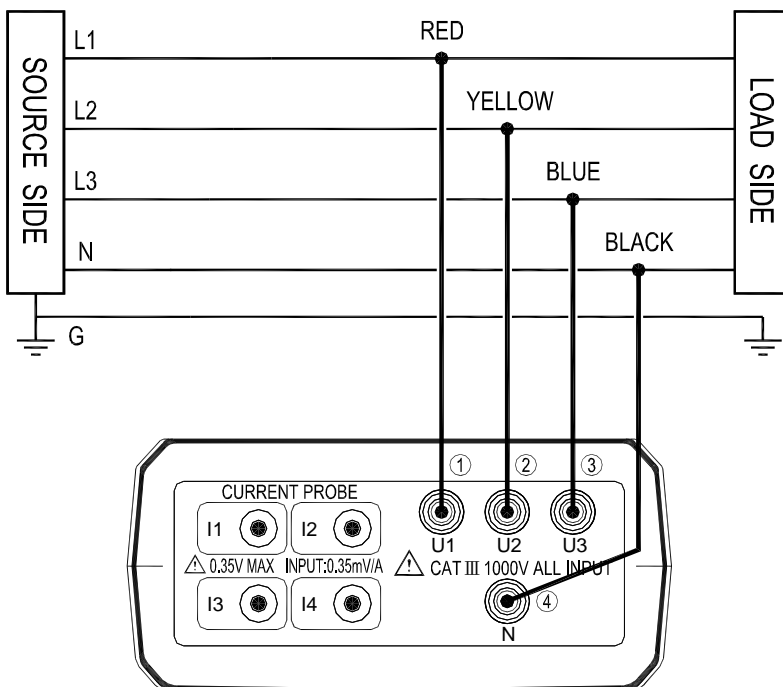









Figure 16. 3P4W Phase Sequence Connection Diagram

1. Press  key to turn on the instrument.
2. Press **“WIRING”** key to select the 3P4W electrical system test, the “3P4W” symbol will be displayed.
3. Connect the voltage test leads to the instrument:
 - ① Connect the red voltage test lead to the “U1” terminal.
 - ② Connect the yellow voltage test lead to the “U2” terminal.
 - ③ Connect the blue voltage test lead to the “U3” terminal.
 - ④ Connect the black voltage test lead to the “N” terminal.
4. Connect the voltage test leads to the electrical equipment to be tested as shown in Figure 14. 3P4W Phase Sequence Connection Diagram

 **CAUTION:** Where possible, isolate the power to the electrical circuit to be tested before connecting the voltage test leads and current probes

- ① Connect the red voltage test alligator clip to Phase 1 “L1”.
- ② Connect the yellow voltage test alligator clip to Phase 2 “L2”.
- ③ Connect the blue voltage test alligator clip to Phase 3 “L3”.
- ④ Connect the black voltage test lead to the “N” terminal.

Note. U1, U2 and U3 measured voltage must be greater than 30V, for rotary field detection

5. Press and hold down the  key.
If the equipment under test is connected to the phases correctly, the clockwise rotation symbol  “” is displayed.
If the phases are reversed, the counter clockwise symbol  “” is displayed.
Release the  key to exit this measurement.

5-11 Voltage, Current Waveform and Harmonic Analyzer



These measurements can be performed via a PC using the software supplied. Please refer to software manual (on the CD-ROM) for waveform and harmonic measurement.

5-12 Enable Auto Power Off Function

The instrument will automatically enter sleep mode after approximately 30 minutes to save power consumption, when enable auto power function.

1. Enable auto power off procedure:

① Press  key to turn off the instrument.

② Press and hold down the “**TIME**” key, then press  key to turn on the instrument, the auto power function will be enabled, and the auto power off symbol  will be appear.

2. Auto power off mode is disabled each time the instrument is turned on and is automatically disabled as the follow modes:

① ENERGY function is active.

② Auto data logging function is active.

③ When linked to a PC.



VI. MAINTENANCE

6-1 General Maintenance

1. Repairs or services that are not covered in this manual should only be performed by qualified personnel.
2. Clean the instrument and accessories with a damp cloth and a mild soap. Do not use abrasives, solvent, or alcohol.
3. It is recommended to open the jaws of the current probe and wipe the magnetic pole pieces with a lightly oiled cloth. This is to avoid rust or corrosion forming on the magnetic poles.

6-2 Battery Replacement

WARNING

- To avoid electric shock, disconnect the test leads and current probes before replacing the batteries.
 - When replacing the batteries, do not mix batteries of different types or old and new batteries.
 - Check the battery polarity carefully when inserting the batteries.
 - Do not short-circuit used batteries, disassemble them, or throw them in a fire, doing so may cause the batteries to explode.
 - Dispose of the used batteries in accordance with local regulations.
1. If the battery power is not sufficient, the LCD will display the "" symbol and replacement of the batteries is required.
 2. Disconnect all test leads and current probe from any power electrical source, press  key to turn off the instrument, and remove the test leads from the sockets.
 3. The battery cover is secured to the bottom case by two screws, remove the two screws from the bottom case.
 4. Remove battery cover, take out the batteries and replace with new batteries, observe the correct battery polarity.
 5. Close the battery cover and refit the securing screws



VII. SOFTWARE INSTALLATION AND OPERATION

For the detailed instructions, please refer to the content of the CD-ROM, which has the complete instructions for the software operation and relevant information.

Limited Warranty

This meter is warranted to the original purchaser against defects in material and workmanship for 3 years from the date of purchase. During this warranty period, RS Components will, at its option, replace or repair the defective unit, subject to verification of the defect or malfunction. This warranty does not cover fuses, disposable batteries, or damage from abuse, neglect, accident, unauthorized repair, alteration, contamination, or abnormal conditions of operation or handling.

Any implied warranties arising out of the sale of this product, including but not limited to implied warranties of merchantability and fitness for a particular purpose, are limited to the above. RS Components shall not be liable for loss of use of the instrument or other incidental or consequential damages, expenses, or economic loss, or for any claim or claims for such damage, expense or economic loss. Some states or countries laws vary, so the above limitations or exclusions may not apply to you. For full terms and conditions, refer to the RS website.

Africa**RS Components SA**

P.O. Box 12182,
Vorna Valley, 1686
20 Indianapolis Street,
Kyalami Business Park,
Kyalami, Midrand
South Africa
www.rs-components.com

Asia**RS Components Pte Ltd.**

31 Tech Park Crescent
Singapore 638040
www.rs-components.com

China**RS Components Ltd.**

Suite 23 A-C
East Sea Business Centre
Phase 2
No. 618 Yan'an Eastern Road
Shanghai, 200001
China
www.rs-components.com

Europe**RS Components Ltd.**

PO Box 99, Corby,
Northants.
NN17 9RS
United Kingdom
www.rs-components.com

Japan**RS Components Ltd.**

West Tower (12th Floor),
Yokohama Business Park,
134 Godocho, Hodogaya,
Yokohama, Kanagawa 240-0005
Japan
www.rs-components.com

U.S.A**Allied Electronics**

7151 Jack Newell Blvd. S.
Fort Worth,
Texas 76118
U.S.A.
www.alliedelec.com

South America**RS Componentes Limitada**

Av. Pde. Eduardo Frei M. 6001-71
Centro Empresas El Cortijo
Conchalí, Santiago, Chile
www.rs-components.com