

SIRIUS

Halbleiterschütz
Semiconductor contactor
Contacteur statique
Contactor estático
Contattore a semiconduttore
Contator semiconductor

3RF24..-AB..
3RF24..-AC..



DIN EN 60 947-4-3

Betriebsanleitung Instructivo		Operating Instructions Istruzioni Operative		Instructions de Service Instruções de Operação	
Deutsch		English		Français	
<p>Vor der Installation, dem Betrieb oder der Wartung des Geräts muss diese Anleitung gelesen und verstanden werden.</p> <p>Eine sichere Gerätefunktion ist nur mit zertifizierten Komponenten gewährleistet!</p>		<p>Read and understand these instructions before installing, operating, or maintaining the equipment.</p> <p>Reliable functioning of the equipment is only ensured with certified components.</p>		<p>Ne pas installer, utiliser ou intervenir sur cet équipement avant d'avoir lu et assimilé les présentes instructions et notamment les conseils de sécurité et mises en garde qui y figurent.</p> <p>La sécurité de fonctionnement de l'appareil n'est garantie qu'avec des composants certifiés.</p>	
⚠ GEFAHR		⚠ DANGER		⚠ DANGER	
<p> Gefährliche Spannung. Lebensgefahr oder schwere Verletzungsgefahr. Vor Beginn der Arbeiten Anlage und Gerät spannungsfrei schalten.</p>		<p>Hazardous voltage. Will cause death or serious injury. Turn off and lock out all power supplying this device before working on this device.</p>		<p>Tension électrique. Danger de mort ou risque de blessures graves. Mettre hors tension avant d'intervenir sur l'appareil.</p>	
⚠ GEFAHR		⚠ DANGER		⚠ DANGER	
<p> Gefährliche Spannung. Lebensgefahr oder schwere Verletzungsgefahr. Um elektrische Stromschläge oder Verbrennungen zu vermeiden, dürfen Sie die Klemmen des Halbleiterschützes nicht berühren, wenn an dessen Eingang Spannung liegt. Die Ausgangsklemme steht auch im AUS-Zustand des Halbleiterschützes unter Spannung (Leckstrom, Halbleiter durchlegiert).</p>		<p>Hazardous voltage. Will cause death or serious injury. To avoid electric shock and burns, never touch the terminals of the semiconductor contactor if voltage is present at its input.</p> <p>The output terminal remains live even in the OFF state of the semiconductor contactor (leakage current, semiconductor breakdown).</p>		<p>Tension dangereuse. Danger de mort ou risque de blessures graves. Ne pas toucher les bornes du relais statique lorsqu'une tension est appliquée à son entrée. Risque d'électrocution et de brûlure !</p> <p>La borne de sortie est aussi sous tension à l'état BLOQUE du relais statique (courant de fuite, semi-conducteur claqué).</p>	
Español		Italiano		Português	
<p>Leer y comprender este instructivo antes de la instalación, operación o mantenimiento del equipo.</p> <p>El funcionamiento seguro del aparato sólo está garantizado con componentes certificados.</p>		<p>Leggere con attenzione queste istruzioni prima di installare, utilizzare o eseguire manutenzione su questa apparecchiatura.</p> <p>Il funzionamento sicuro dell'apparecchiatura è garantito soltanto con componenti certificati.</p>		<p>Ler e compreender estas instruções antes da instalação, operação ou manutenção do equipamento.</p> <p>O funcionamento seguro do aparelho apenas pode ser garantido se forem utilizados os componentes certificados.</p>	
⚠ PELIGRO		⚠ PERICOLO		⚠ PERIGO	
<p> Tensión peligrosa. Puede causar la muerte o lesiones graves. Desconectar la alimentación eléctrica antes de trabajar en el equipo.</p>		<p>Tensione pericolosa. Può provocare morte o lesioni gravi. Scollegare l'alimentazione prima di eseguire interventi sull'apparecchiatura.</p>		<p>Tensão perigosa. Perigo de morte ou ferimentos graves. Desligue a corrente antes de trabalhar no equipamento.</p>	
⚠ PELIGRO		⚠ PERICOLO		⚠ PERIGO	
<p> Tensión peligrosa. Puede causar la muerte o lesiones graves. Para evitar choques eléctricos o quemaduras no se deberán tocar los bornes del relé estático cuando su entrada esté bajo tensión. El borne de salida está también bajo tensión incluso si el relé estático se encuentra en estado DES (por causa de corriente de fuga o cortocircuito interno del semiconductor).</p>		<p>Tensione pericolosa. Può provocare morte o lesioni gravi. Per evitare shock elettrici e ustioni, non toccare i morsetti del relè statici quando il suo ingresso è sotto tensione.</p> <p>Il morsetto di uscita è sotto tensione anche quando il relè statici è disinserito (corrente di dispersione, semiconduttore in cortocircuito).</p>		<p>Tensão perigosa. Perigo de morte ou ferimentos graves. De modo a evitar choques eléctricos ou queimaduras não pode tocar nos bornes do relé semiconductor se a entrada do mesmo estiver sob tensão.</p> <p>O borne de saída está sob tensão, mesmo quando o relé semiconductor estiver em estado DESLIGADO (corrente de fuga, semiconductor com liga).</p>	

DE	EN	FR	ES	IT	PT
Maßbilder	Dimension drawings	Encombremet	Croquis acotados	Disegni quotati	Desenhos dimensionais

**3RF2410-AB.., 3RF2410-AC..,
3RF2420-AB.., 3RF2420-AC..,
3RF2430-AB..**

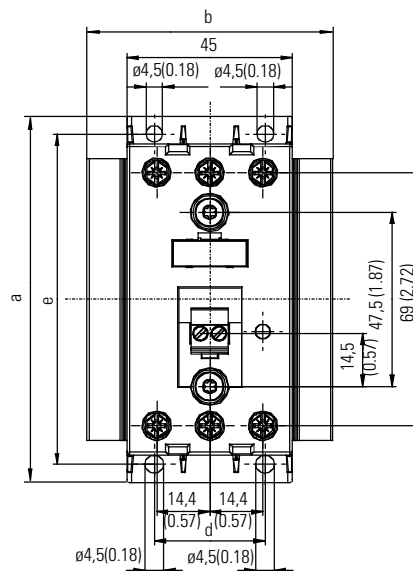
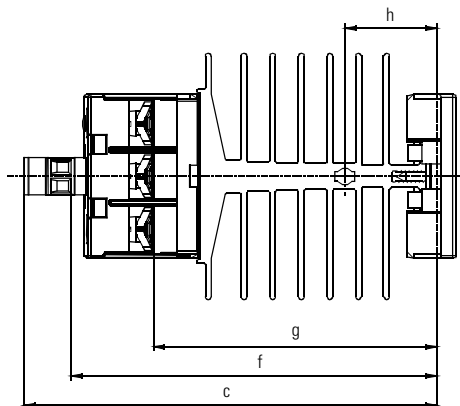

**3RF2430-AC..
3RF2440-AB.., 3RF2440-AC..,
3RF2450-AB.., 3RF2450-AC..**

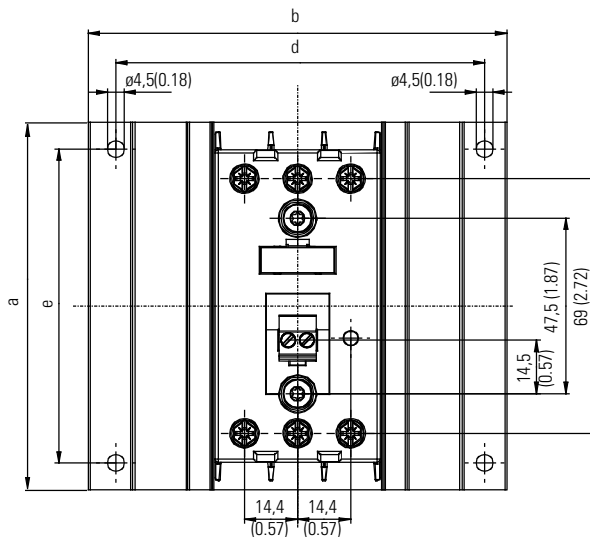
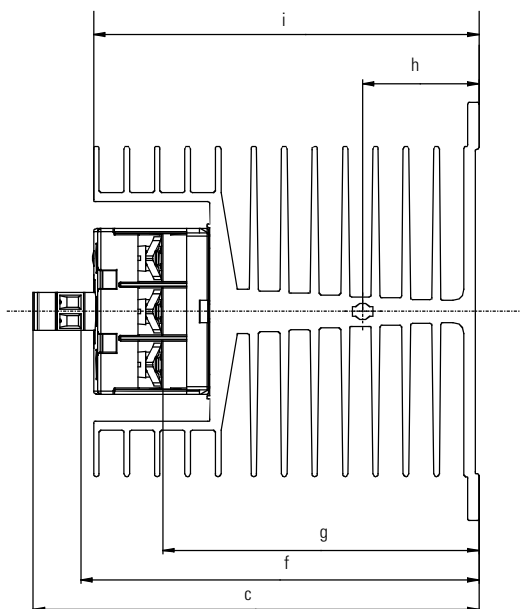

	a	b	c	d	e	f	g	h	i
3RF2410-AC.. 3RF2410-AB..	100 (3.94)	45 (1.77)	104,5 (4.11)	30 (1.18)	90 (3.54)	91,5 (3.60)	69,5 (2.74)	25 (0.98)	—
3RF2420-AB..	100 (3.94)	67 (2.64)	112,5 (4.43)	30 (1.18)	90 (3.54)	99,5 (3.92)	77 (3.03)	25 (0.98)	—
3RF2420-AC.. 3RF2430-AB..	100 (3.94)	89,5 (3.52)	112,5 (4.43)	30 (1.18)	90 (3.54)	99,5 (3.92)	77 (3.03)	25 (0.98)	—
3RF2430-AC.. 3RF2440-AB..	100 (3.94)	113,5 (4.47)	121 (4.76)	100 (3.94)	85 (3.35)	108 (4.25)	86 (3.39)	31,5 (1.24)	104,5 (4.11)
3RF2440-AC.. 3RF2450-AB..	100 (3.94)	157,5 (6.20)	121 (4.76)	146 (5.75)	80 (3.15)	108 (4.25)	86 (3.39)	31,5 (1.24)	104,5 (4.11)
3RF2450-AC..	180 (7.09)	157,5 (6.20)	121 (4.76)	146 (5.75)	160 (6.30)	108 (4.25)	86 (3.39)	31,5 (1.24)	104,5 (4.11)

DE	EN	FR	ES	IT	PT
Montage	Assembly	Montage	Montaje	Montaggio	Montagem

**3RF2410-AB.., 3RF2410-AC..,
3RF2420-AB.., 3RF2420-AC..,
3RF2430-AB..**

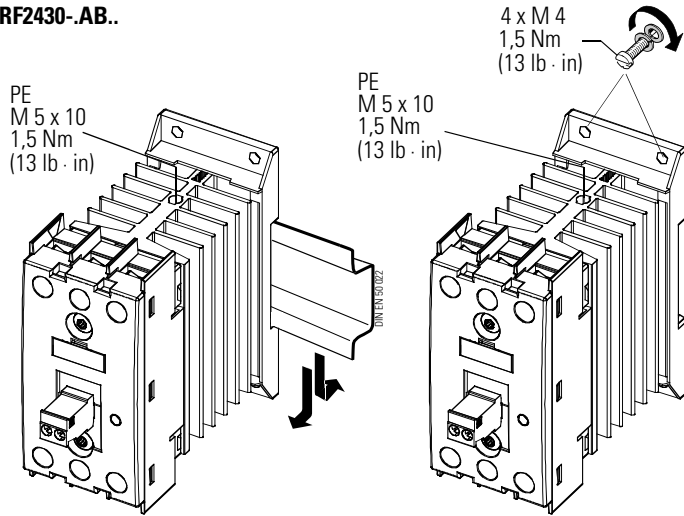

**3RF2430-AC..
3RF2440-AB.., 3RF2440-AC..,
3RF2450-AB.., 3RF2450-AC..**

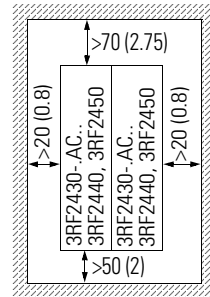
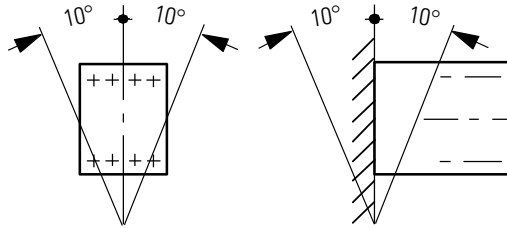
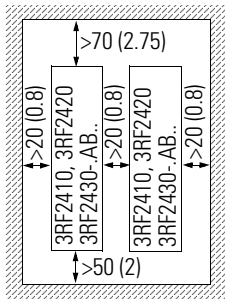
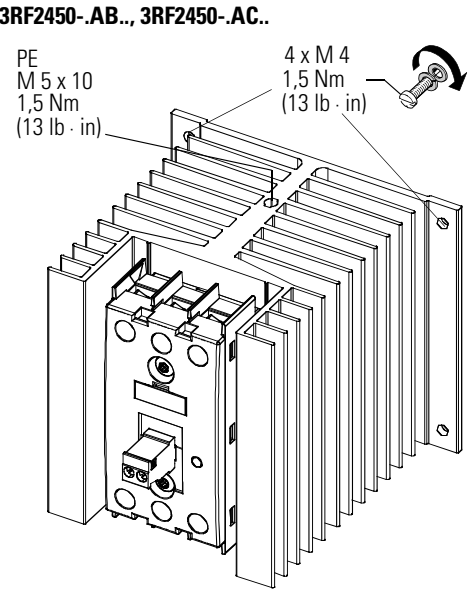

DE	EN	FR	ES	IT	PT
Anschluss	Connection	Connexion	Conexión	Connettore	Conexão

3RF24..-1

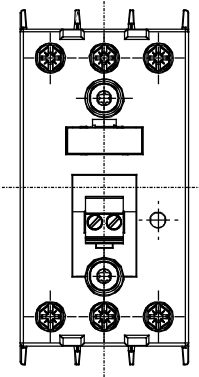



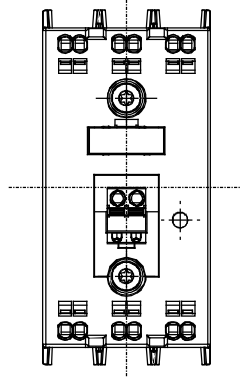



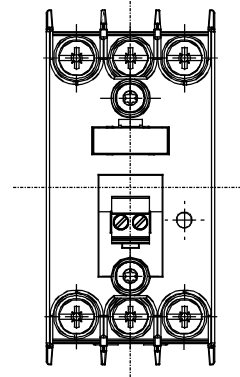



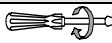
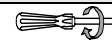

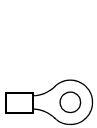

3RF24..-2



3RF24..-3



DE	EN	FR	ES	IT	PT
Anschlussquerschnitte und Anzugsdrehmomente	Conductor cross-sections and tightening torques	Section des conducteurs de raccordement et couples de serrage	Secciones de cables de conexión y pares de apriete	Sezioni dei conduttori di collegamento e coppie di serraggio	Seções transversais de conexão e torques de aperto

	3RF24..-1			3RF24..-2			3RF24..-3	
	L1 - T3	A1 - A2		L1 - T3	A1 - A2		L1 - T3	A1 - A2
 Ø 5 ... 6 mm / PZ2	2 ... 2,5 Nm 18 ... 22 lbf · in	—	—	—	—	 Ø 5 ... 6 mm / PZ2	2 ... 2,5 Nm 18 ... 22 lbf · in	—
	2 x 1,5 ... 2,5 mm ² 2 x 2,5 ... 6 mm ²			2 x 0,5 ... 2,5 mm ²			DIN 46234 5 - 2,5 ... 5 - 16	
	2 x 1,5 ... 2,5 mm ² 2 x 2,5 ... 6 mm ² 1 x 10 mm ²			2 x 0,5 ... 1,5 mm ²			JIS C 2805 R 2 - 5 ... 14 - 5	
AWG	2 x 14 ... 10		AWG	2 x 18 ... 14		AWG	R 2 - 5 ... 14 - 5	
 Ø 3,5 mm / PZ1	—	0,5 ... 0,6 Nm 4,5 ... 5,3 lbf · in	—	—	—	 Ø 3,5 mm / PZ1	0,5 ... 0,6 Nm 4,5 ... 5,3 lbf · in	—
	—	1 x 0,5 ... 2,5 mm ² 2 x 0,5 ... 1 mm ²		—	1 x 0,5 ... 2,5 mm ²		—	1 x 0,5 ... 2,5 mm ² 2 x 0,5 ... 1 mm ²
	—	1 x 0,5 ... 2,5 mm ² 2 x 0,5 ... 1 mm ²		—	1 x 0,5 ... 2,5 mm ²		—	1 x 0,5 ... 2,5 mm ² 2 x 0,5 ... 1 mm ²
AWG	—	1 x 20 ... 12	AWG	—	1 x 20 ... 12	AWG	—	1 x 20 ... 12

DE	EN	FR	ES	IT	PT
Schaltungsskizze	Circuit diagram	Schéma intérieur	Esquema eléctrico	Schema elettrico	Esquema do circuito

3RF24..-AB4.

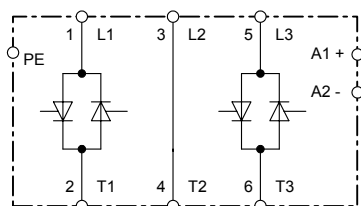

DC 4 ... 30 V

3RF24..-AB3.

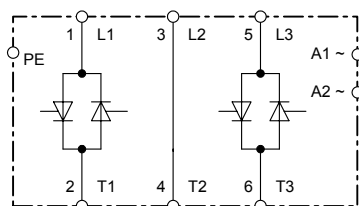

AC 110 V

3RF24..-AB5.

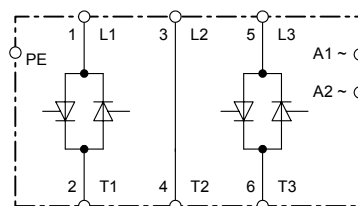

AC 230 V

3RF24..-AC4.

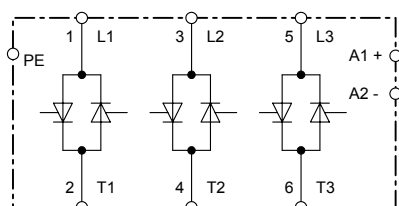

DC 4 ... 30 V

3RF24..-AC3.

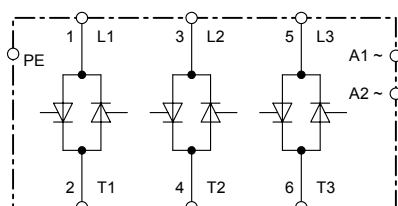

AC 110 V

3RF24..-AC5.

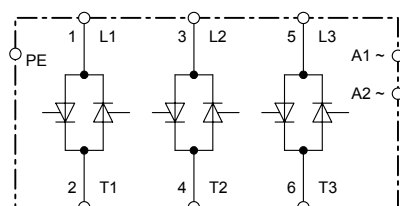

AC 230 V

Technical Assistance: Telephone: +49 (0) 911-895-5900 (8⁰⁰ - 17⁰⁰ CET)
 E-mail: technical-assistance@siemens.com
 Internet: www.siemens.de/lowvoltage/technical-assistance

Technical Support: Telephone: +49 (0) 180 50 50 222

Fax: +49 (0) 911-895-5907

Technische Änderungen vorbehalten. Zum späteren Gebrauch aufbewahren.
 Subject to change without prior notice. Store for use at a later date.
 © Siemens AG 2005

Bestell-Nr./Order No.: 3ZX1012-0RF24-2AA1
 Printed in the Federal Republic of Germany