

Preparation

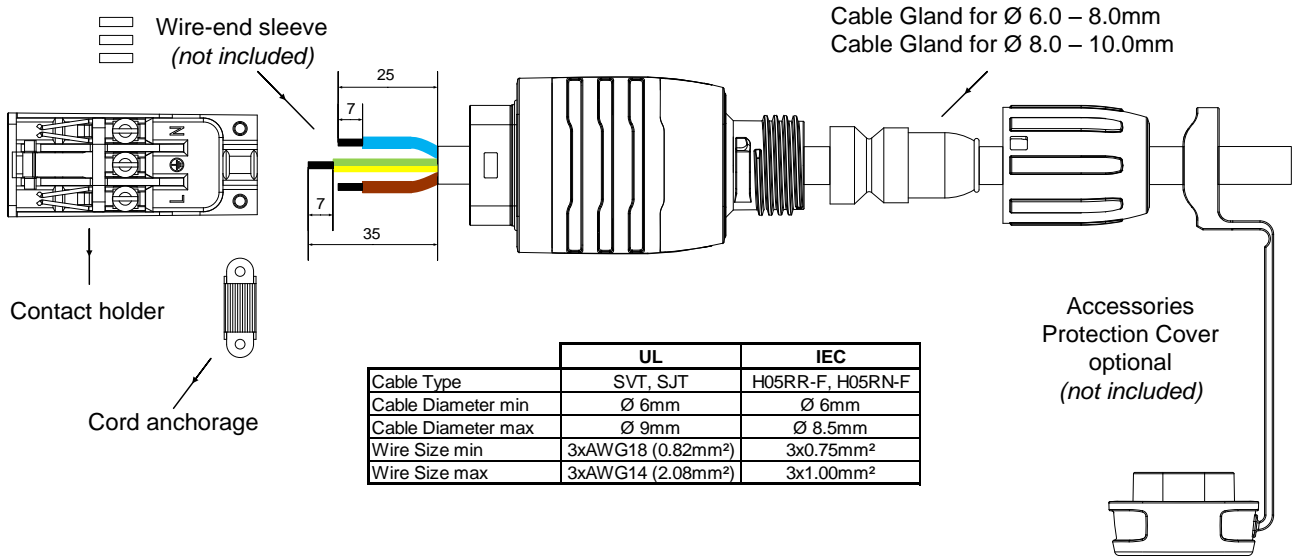

Conductor connection & cord anchorage assembly

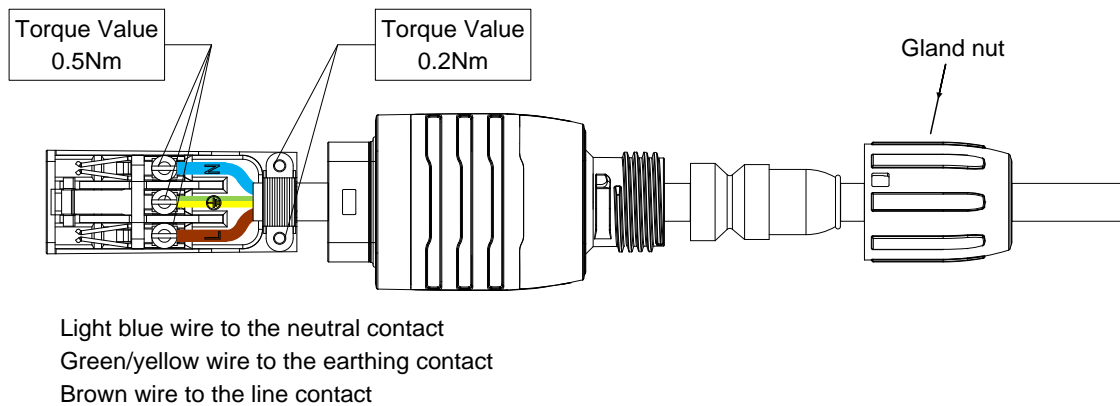

Connector assembly

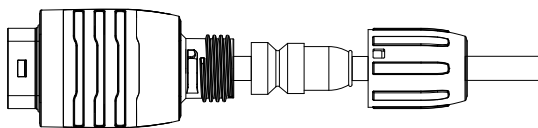

Slide the contact holder into the connector – “click sound”

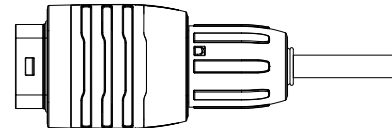

Screw the gland nut onto the connector until the locking

Engineering Documentation

Mounting Instruction 4761-4762

owner	creation date	release date	released by	change order no	rev	page	0115.0074
huberth	2016-07-11	2016-07-14	huberth	2010231	B	1 of 3	

Preparation

1. Disconnect power before wiring.
2. Loosen gland nut and remove cable gland.
3. Select cable gland according to the cable diameter
4. Remove contact holder and loosen terminal screws but do not remove screws. Loosen cord anchorage screws and remove the cord anchorage.
5. Keep removed piece parts at a safe place to have them ready for reassembling.
6. Insert the cord through the gland nut, cable gland and connector in this succession.
7. Optional accessories protection cover: Insert the cord first in the loop of the protection cover.
8. Remove 35mm outer jacket of the cord. Make sure to not injure the insulation of single conductors.
9. Reduce the length of the "neutral" and "line" wire to 25mm.
10. Strip the insulation from the wires at a length of 7mm and crimp on cable-end sleeves. Do not strip more than 7mm.

Conductor connection & cord anchorage assembly

1. Connect green or green/yellow (ground) wire to clamp marked with ground symbol.
2. Connect blue (white or light grey) wire to clamp marked „N“ (neutral).
3. Connect brown (black / "hot") wire to clamp marked „L“ (line).
4. Tighten all wire clamp screws with a torque of 0.5 Nm.
5. Assemble cord anchorage over cut-off end of outer jacket of the cord and tighten cord anchorage screws with a torque of 0.2 Nm.

Connector assembly

1. Slide the contact holder into the connector. If you hear the click sound the contact holder is fixed. It is not possible to remove it without the aid of a tool.
2. Slide the cable gland into the connector.
3. Screw the gland nut onto the connector until you can see the latch through the opening. It is not possible to remove it without the aid of a tool.

Warning

- Failure to assembly as instructed may cause personal injury or damage to device or equipment.
- To be installed or checked by a qualified person only.
- For factory assembly only.

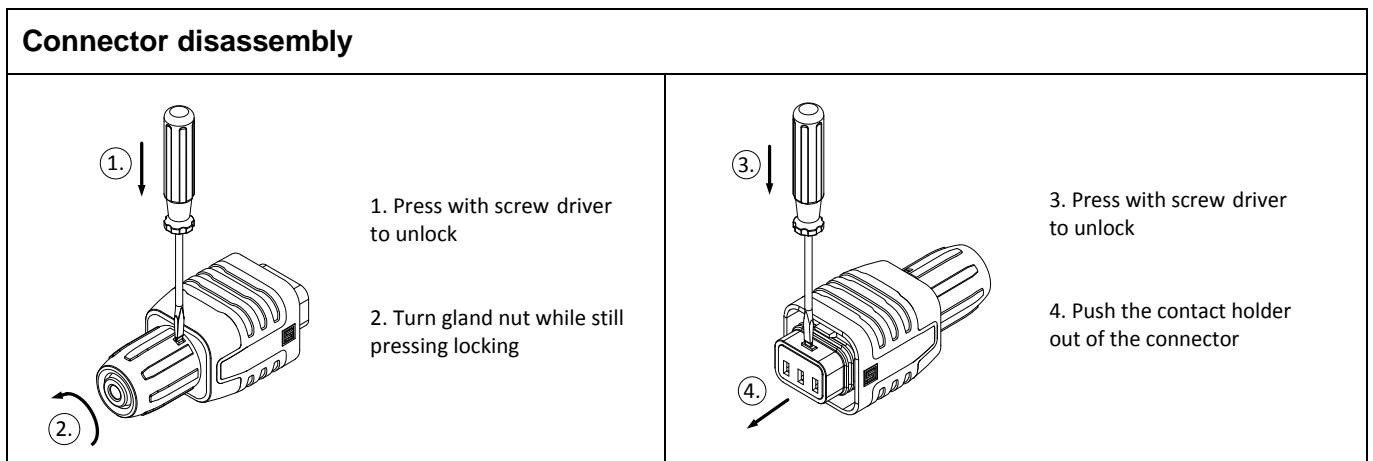

Engineering Documentation					Mounting Instruction 4761-4762		
owner	creation date	release date	released by	change order no	rev	page	0115.0074
huberth	2016-07-11	2016-07-14	huberth	2010231	B	2 of 3	

Inlet assembly

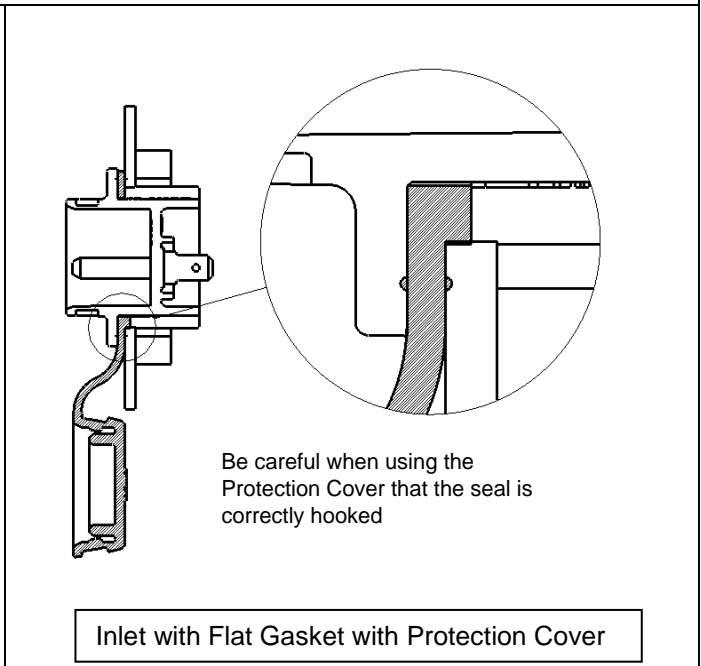
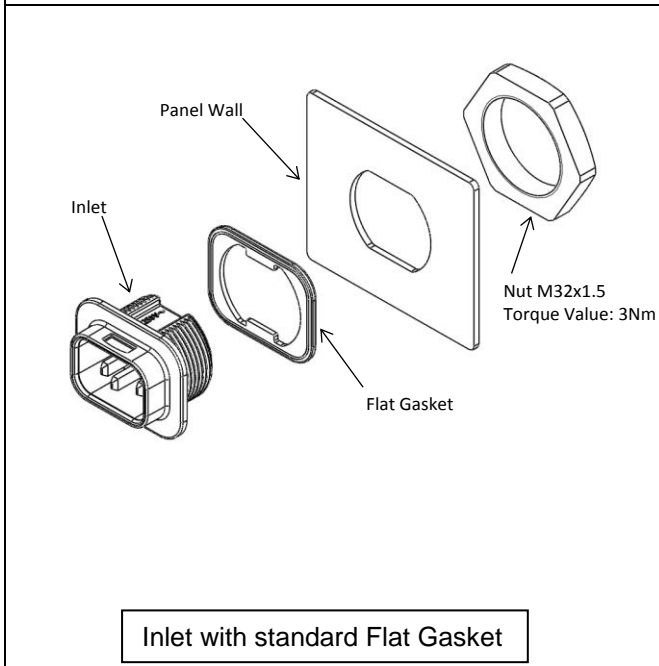

Inserting the Connector in the Inlet

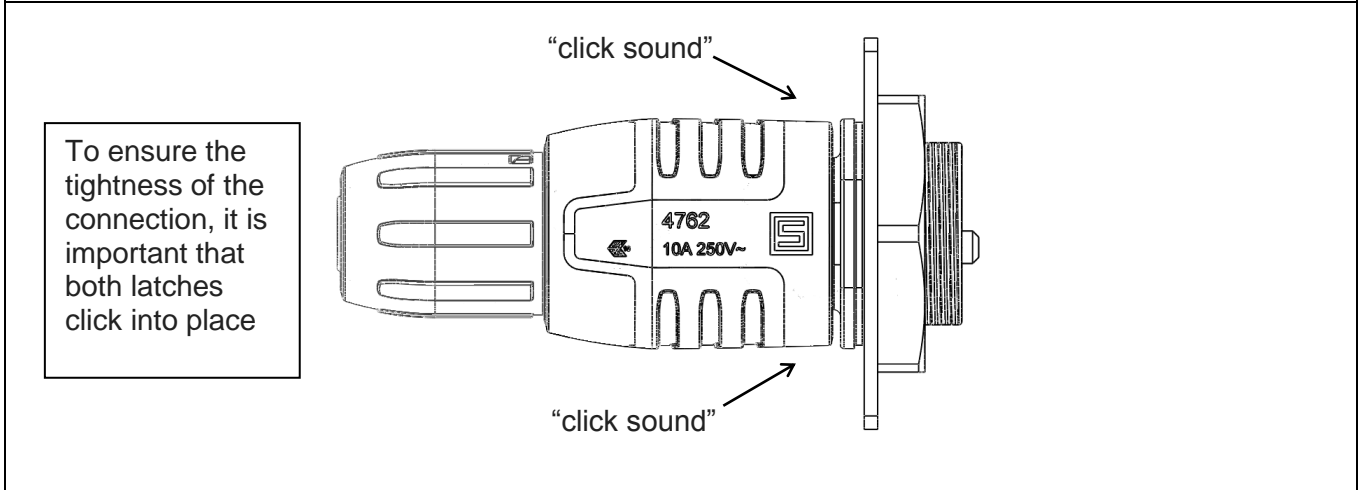
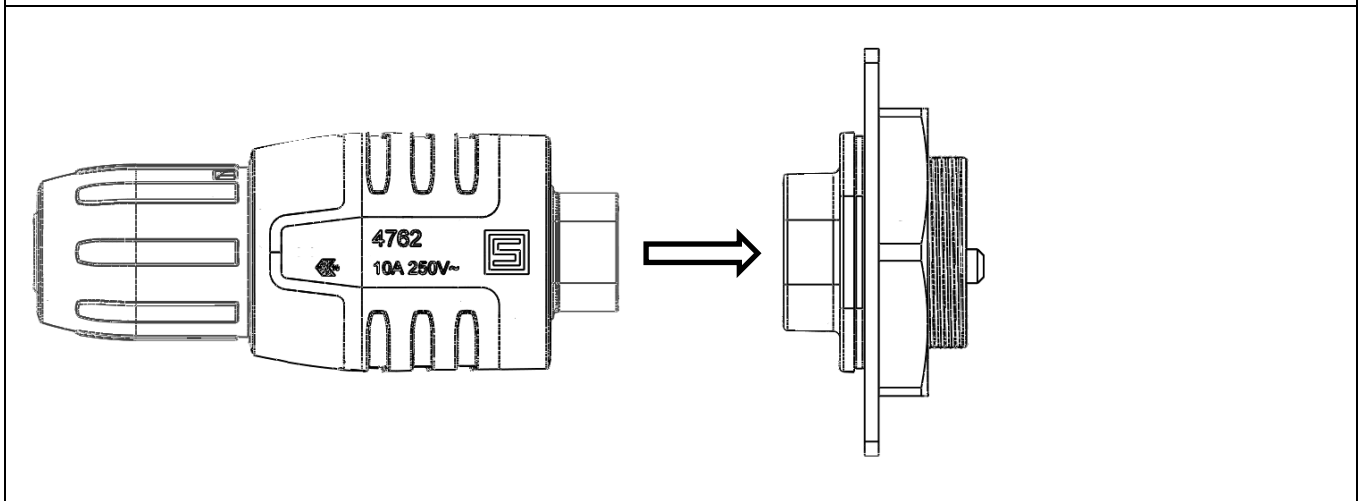

Engineering Documentation					Mounting Instruction 4761-4762		
owner	creation date	release date	released by	change order no	rev	page	0115.0074
huberth	2016-07-11	2016-07-14	huberth	2010231	B	3 of 3	