

Lift - Up & Down

Tilt - Backward & Forward

Physical dimensions:(mm)

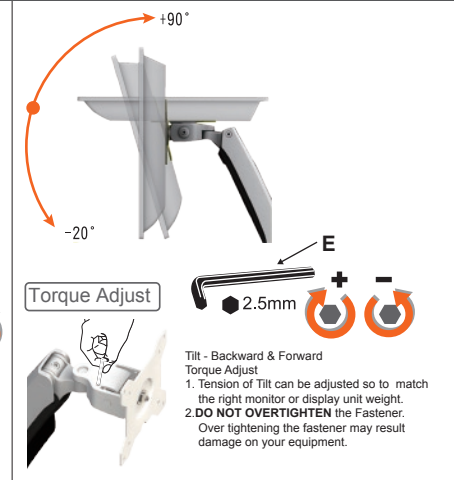
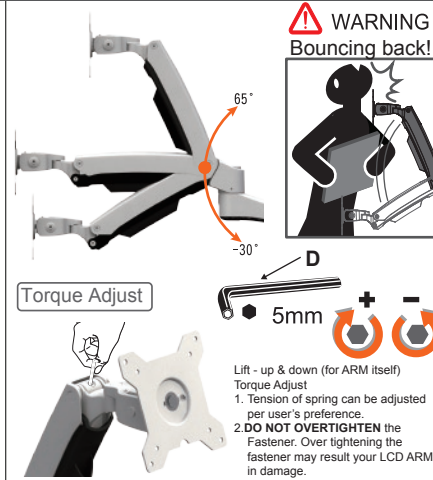
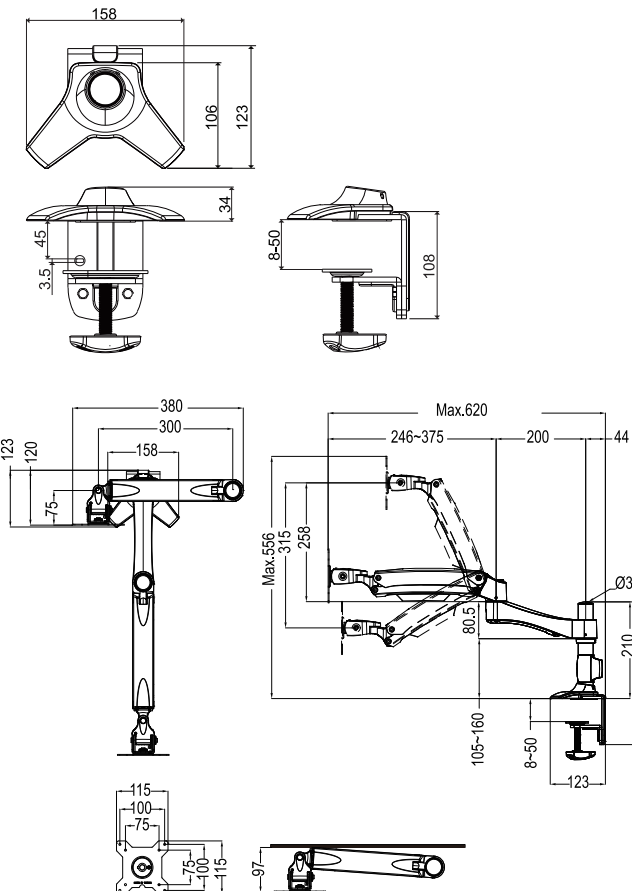

Arm Swing Adjust

Rotate (Pivot)

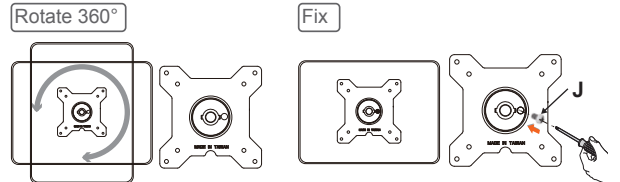
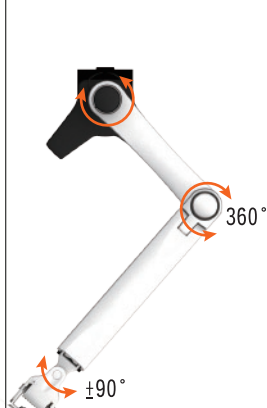

Cable Management

