

**RND**  
power

.....  
USER MANUAL

**RND 315-00017**

**RND 315-00018**

AC-DC DIN RAIL MOUNTED  
POWER SUPPLY

480W

## AC-DC Din Rail Mountable Power Supply SINGLE PHASE INPUT

### Features

- Universal Input 90-264Vac
- 100% Full Load Burn-in Test
- Cooling by Free Air Convection
- All Round Protections: Short Circuit, Over Voltage, Over Current, Over Temperature
- LED Indicator for DC Power On
- LED Indicator for DC Low



### Applications

- ✓ Process Control
- ✓ Traffic & Transportation System
- ✓ Factory Automation
- ✓ Other Industrial Applications

### Electrical

| Part Number   | Nominal Input Voltage | Output Voltage | Output Current | Ripple (Max.) | Efficiency |     | Certificate |
|---------------|-----------------------|----------------|----------------|---------------|------------|-----|-------------|
|               |                       |                |                |               |            | Typ |             |
| RND 315-00017 | 100-240VAC            | 24V            | 20A            | 1%Vo<br>mVp-p |            | 94% | CE, UL      |
| RND 315-00018 | 100-240VAC            | 48V            | 10A            | 1%Vo<br>mVp-p |            | 94% | CE, UL      |

#### NOTE:

1. The ripple values are measured at 20MHz of bandwidth by using a 12" twisted pair-wire terminated with 0.1uF & 47uF parallel capacitor under ambient temperature 25°C at rated input voltage and rated load;
2. The efficiency values are measured under ambient temperature 25°C at rated input voltage and rated load.

### INPUT

| PARAMETER                  | CONDITIONS   | MIN | TYP          | MAX      | UNITS  |
|----------------------------|--|-----|--------------|----------|--------|
| Input voltage              |  | 90  |              | 264      | Vac    |
| Input frequency            |  | 47  |              | 63       | Hz     |
| Input current              | Full load, Vin=115Vac<br>Full load, Vin=230Vac   |     |              | 5<br>2.5 | A<br>A |
| Inrush current             | Cold start, Vin=115Vac<br>Cold start, Vin=230Vac   |     |              | 40<br>80 | A<br>A |
|                            | 1. This product is built in inrush limiting circuit to protect the circuit from surge current damages when the power is turned on. Malfunction can occur by repeating the input voltage on and off rapidly. Therefore, sufficient interval should be given between turning on and off the power;<br>2. To avoid connecting the switch or fuse to input terminal(outside of the power supply), more consideration should be given when selecting the parts that can endure the inrush current |     |              |          |        |
| Power factor(PF)           | Full load, Vin=115Vac<br>Full load, Vin=230Vac   |     | 0.99<br>0.97 |          |        |
| Stand-by power consumption | Vin=230Vac   |     |              | 5        | W      |
| Surge voltage              | L-N  |     |              | 2        | KV     |

### OUTPUT

| PARAMETER                       | CONDITIONS   | MIN | TYP   | MAX | UNITS |
|---------------------------------|--|-----|-------|-----|-------|
| Output voltage accuracy         |  |     |       | 2   | %     |
| Output voltage adjustment range | RND 315-00017  |     | 22-27 |     | V     |
|                                 | RND 315-00018  |     | 43-52 |     | V     |
|                                 | Output voltage can be adjusted within above range by V-ADJ. variable resistance inside of the power supply. When output voltage exceeds the range, the power supply will be in failure or get into over voltage protection mode. To avoid the case that the output voltage is higher than rated voltage, output current should be used under rated current |     |       |     |       |
| Minimum load                    |  | 0   |       |     | %     |
| Line regulation                 | Vin from 100Vac to 240Vac  |     |       | 2   | %     |
| Load regulation                 | Vout from min. to max.   |     |       | 3   | %     |
| Turn-on delay time              | Full load, Vin=115Vac  |     | 3600  |     | ms    |
| Hold up time                    | Full load, Vin=115Vac  |     | 20    |     | ms    |

### Protection

|                  |   |
|------------------|---|
| Short circuit    | Hiccup mode, it will recover automatically after fault condition is removed   |
| Over voltage     | RND 315-00017: over voltage protection value 32V<br>RND 315-00018: over voltage protection value 62V  |
|                  | (1) When output voltage exceeds above over voltage protection value or reversal voltage occurs, the protection will be started and the output voltage will be cut off in order to protect the power supply;<br>(2) The power supply will recover after the power is turned on again |
| Over current     | RND 315-00017: over current protection value 30A<br>RND 315-00018: over current protection value 15A  |
|                  | (1) When output voltage exceeds above over current protection value, the protection will be started and the output voltage will be cut off in order to protect the power supply;<br>(2) The power supply will recover automatically after the fault condition is removed            |
| Over temperature | Over temperature protection value: 110±10°C   |
|                  | (1) When the ambient temperature exceeds above over temperature protection value, the protection will be started and go into hiccup mode;<br>(2) The power supply will recover automatically after the fault condition is removed   |



### Electrical Curve

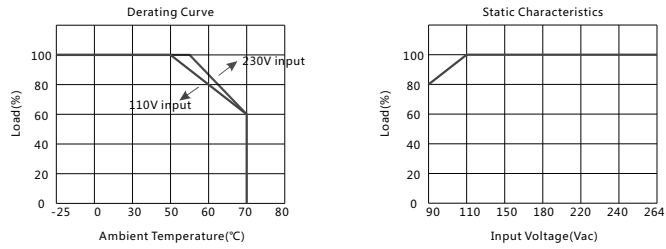

### Block Diagram

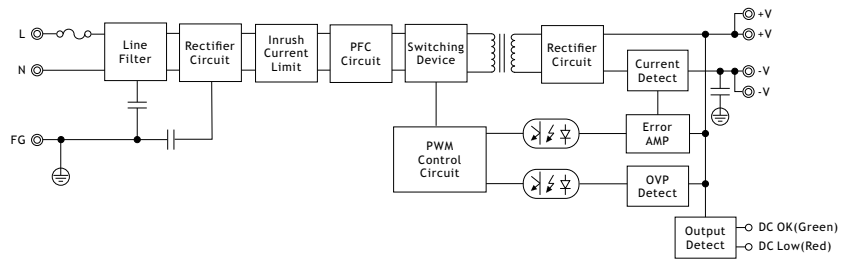

### Application Note

#### 1. Series Operation

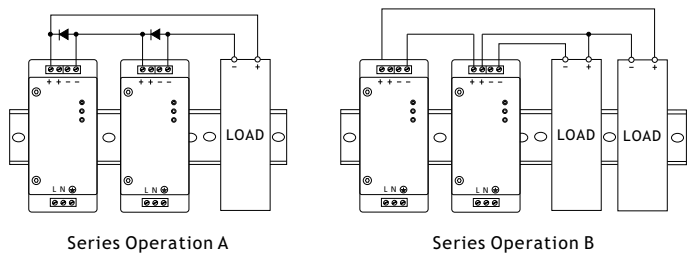

- Note:
1. Series operation can be connected as shown in above;
  2. Load current should be less than the current value of the product with the lowest output current specified at the product specification with the power supply at series connection.

### Application Note

#### 2. Parallel Operation

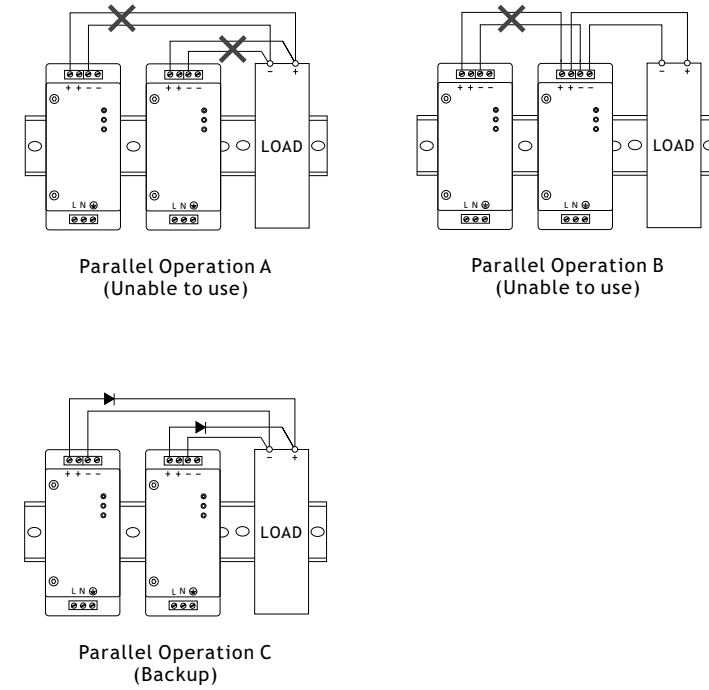

- Note:
1. Parallel operation should be composed with the same products, while the connection should be as shown as "Parallel operation C";
  2. In parallel operation C, current capacity cannot be increased, while it should be used for backup only. Moreover, diode that is to be added during parallel operation should be selected after considering its voltage drop, output voltage and current capacity.

### Application Note

#### 3. Mounting Method

##### (1) How to fix

Firstly hang A part on the top of Rail as shown in below, then push the power supply into B direction to fix it.

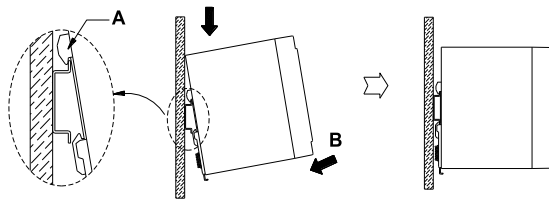

##### (2) How to remove

Remove the power supply to D direction, pulling C part by using tools, such as a screwdriver, to downward direction.

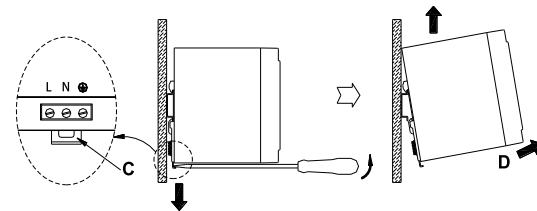

#### 3. Mounting Method

##### (3) Mounting Spacing

Mounting method should be considered with airflow. Leave enough space between the units when several units are mounted together. Forced air cooling makes protection against heat better.

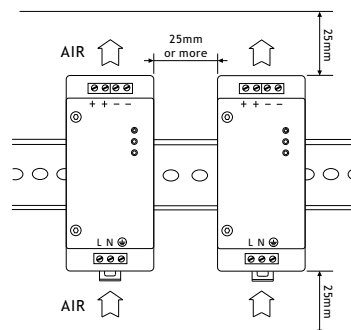

### Application Note

#### 4. Cautions

- (1) Please confirm if the capacity of the product is suitable for your intended application before putting it in use;
- (2) Only the rated input voltage specified on the product should be used;
- (3) Only the wires with rated capacity should be connected to this product, as allowable voltage and current is varied according to each type of wire;
- (4) Ground terminal of the power supply must be grounded before use to prevent electric shock or electromagnetic interference;
- (5) Be cautions to keep the product clean as foreign matter near the input & output terminal or inside if the product could cause series damages;
- (6) If a fuse installed in the product blows off, the product should experience damages not only to the fuse but also to other parts as well. Therefore, the product is to be required for maintenance work from customer service department as well as replacement of the fuse;
- (7) Due to constant leakage current flows within the product, extra caution should be made if multiple number of products are used connecting to each other as total leakage current could be amounted beyond the capacity;
- (8) Be sure to avoid any physical contact with the product since some of the parts inside of the product are being functioned at high voltage, which could cause serious electric shock;
- (9) For the purpose of safety as well as reliability of the product, please avoid using the product at the following sites:
  - A place near water or fire
  - A place with high room temperature and poor ventilation
  - A place with a presence of foreign subject or dust
  - A place near volatile or flammable compounds
  - A place with high humidity
  - A place vulnerable for vibration or shock
- (10) Do not inspect or repair the product while the power is applied;
- (11) Unauthorized modification should be avoided in order to prevent series injury or physical loss due to any malfunction;
- (12) In case of power outage while in operation, be sure to turn off the power supply.

### Application Note

#### 5. Warranty

- (1) Repair service will be provided for free upon any mechanical, technical or functional defects during the guaranteed warranty, however, any defects or malfunction due to international infliction or negligence by customers will be repaired at the customer's expense;
- (2) Guaranteed warranty of the product runs for 3 years, while appearance and specification of the product is subject for change without any prior notification for the purpose of quality improvement of the product.

