

RSSKRX23E-A

User's Manual

32

All information contained in these materials, including products and product specifications, represents information on the product at the time of publication and is subject to change by Renesas Electronics Corp. without notice. Please review the latest information published by Renesas Electronics Corp. through various means, including the Renesas Electronics Corp. website (<http://www.renesas.com>).

Notice

1. Descriptions of circuits, software and other related information in this document are provided only to illustrate the operation of semiconductor products and application examples. You are fully responsible for the incorporation or any other use of the circuits, software, and information in the design of your product or system. Renesas Electronics disclaims any and all liability for any losses and damages incurred by you or third parties arising from the use of these circuits, software, or information.
2. Renesas Electronics hereby expressly disclaims any warranties against and liability for infringement or any other claims involving patents, copyrights, or other intellectual property rights of third parties, by or arising from the use of Renesas Electronics products or technical information described in this document, including but not limited to, the product data, drawings, charts, programs, algorithms, and application examples.
3. No license, express, implied or otherwise, is granted hereby under any patents, copyrights or other intellectual property rights of Renesas Electronics or others.
4. You shall not alter, modify, copy, or reverse engineer any Renesas Electronics product, whether in whole or in part. Renesas Electronics disclaims any and all liability for any losses or damages incurred by you or third parties arising from such alteration, modification, copying or reverse engineering.
5. Renesas Electronics products are classified according to the following two quality grades: "Standard" and "High Quality". The intended applications for each Renesas Electronics product depends on the product's quality grade, as indicated below.
"Standard": Computers; office equipment; communications equipment; test and measurement equipment; audio and visual equipment; home electronic appliances; machine tools; personal electronic equipment; industrial robots; etc.
"High Quality": Transportation equipment (automobiles, trains, ships, etc.); traffic control (traffic lights); large-scale communication equipment; key financial terminal systems; safety control equipment; etc.
Unless expressly designated as a high reliability product or a product for harsh environments in a Renesas Electronics data sheet or other Renesas Electronics document, Renesas Electronics products are not intended or authorized for use in products or systems that may pose a direct threat to human life or bodily injury (artificial life support devices or systems; surgical implantations; etc.), or may cause serious property damage (space system; undersea repeaters; nuclear power control systems; aircraft control systems; key plant systems; military equipment; etc.). Renesas Electronics disclaims any and all liability for any damages or losses incurred by you or any third parties arising from the use of any Renesas Electronics product that is inconsistent with any Renesas Electronics data sheet, user's manual or other Renesas Electronics document.
6. When using Renesas Electronics products, refer to the latest product information (data sheets, user's manuals, application notes, "General Notes for Handling and Using Semiconductor Devices" in the reliability handbook, etc.), and ensure that usage conditions are within the ranges specified by Renesas Electronics with respect to maximum ratings, operating power supply voltage range, heat dissipation characteristics, installation, etc. Renesas Electronics disclaims any and all liability for any malfunctions, failure or accident arising out of the use of Renesas Electronics products outside of such specified ranges.
7. Although Renesas Electronics endeavors to improve the quality and reliability of Renesas Electronics products, semiconductor products have specific characteristics, such as the occurrence of failure at a certain rate and malfunctions under certain use conditions. Unless designated as a high reliability product or a product for harsh environments in a Renesas Electronics data sheet or other Renesas Electronics document, Renesas Electronics products are not subject to radiation resistance design. You are responsible for implementing safety measures to guard against the possibility of bodily injury, injury or damage caused by fire, and/or danger to the public in the event of a failure or malfunction of Renesas Electronics products, such as safety design for hardware and software, including but not limited to redundancy, fire control and malfunction prevention, appropriate treatment for aging degradation or any other appropriate measures. Because the evaluation of microcomputer software alone is very difficult and impractical, you are responsible for evaluating the safety of the final products or systems manufactured by you.
8. Please contact a Renesas Electronics sales office for details as to environmental matters such as the environmental compatibility of each Renesas Electronics product. You are responsible for carefully and sufficiently investigating applicable laws and regulations that regulate the inclusion or use of controlled substances, including without limitation, the EU RoHS Directive, and using Renesas Electronics products in compliance with all these applicable laws and regulations. Renesas Electronics disclaims any and all liability for damages or losses occurring as a result of your noncompliance with applicable laws and regulations.
9. Renesas Electronics products and technologies shall not be used for or incorporated into any products or systems whose manufacture, use, or sale is prohibited under any applicable domestic or foreign laws or regulations. You shall comply with any applicable export control laws and regulations promulgated and administered by the governments of any countries asserting jurisdiction over the parties or transactions.
10. It is the responsibility of the buyer or distributor of Renesas Electronics products, or any other party who distributes, disposes of, or otherwise sells or transfers the product to a third party, to notify such third party in advance of the contents and conditions set forth in this document.
11. This document shall not be reprinted, reproduced or duplicated in any form, in whole or in part, without prior written consent of Renesas Electronics.
12. Please contact a Renesas Electronics sales office if you have any questions regarding the information contained in this document or Renesas Electronics products.

(Note1) "Renesas Electronics" as used in this document means Renesas Electronics Corporation and also includes its directly or indirectly controlled subsidiaries.

(Note2) "Renesas Electronics product(s)" means any product developed or manufactured by or for Renesas Electronics.

(Rev.4.0-1 November 2017)

Corporate Headquarters

TOYOSU FORESIA, 3-2-24 Toyosu,
Koto-ku, Tokyo 135-0061, Japan

www.renesas.com

Contact information

For further information on a product, technology, the most up-to-date version of a document, or your nearest sales office, please visit:

www.renesas.com/contact/.

Trademarks

Renesas and the Renesas logo are trademarks of Renesas Electronics Corporation. All trademarks and registered trademarks are the property of their respective owners.

General Precautions in the Handling of Microprocessing Unit and Microcontroller Unit Products

The following usage notes are applicable to all Microprocessing unit and Microcontroller unit products from Renesas. For detailed usage notes on the products covered by this document, refer to the relevant sections of the document as well as any technical updates that have been issued for the products.

1. Precaution against Electrostatic Discharge (ESD)

A strong electrical field, when exposed to a CMOS device, can cause destruction of the gate oxide and ultimately degrade the device operation. Steps must be taken to stop the generation of static electricity as much as possible, and quickly dissipate it when it occurs. Environmental control must be adequate. When it is dry, a humidifier should be used. This is recommended to avoid using insulators that can easily build up static electricity. Semiconductor devices must be stored and transported in an anti-static container, static shielding bag or conductive material. All test and measurement tools including work benches and floors must be grounded. The operator must also be grounded using a wrist strap. Semiconductor devices must not be touched with bare hands. Similar precautions must be taken for printed circuit boards with mounted semiconductor devices.

2. Processing at power-on

The state of the product is undefined at the time when power is supplied. The states of internal circuits in the LSI are indeterminate and the states of register settings and pins are undefined at the time when power is supplied. In a finished product where the reset signal is applied to the external reset pin, the states of pins are not guaranteed from the time when power is supplied until the reset process is completed. In a similar way, the states of pins in a product that is reset by an on-chip power-on reset function are not guaranteed from the time when power is supplied until the power reaches the level at which resetting is specified.

3. Input of signal during power-off state

Do not input signals or an I/O pull-up power supply while the device is powered off. The current injection that results from input of such a signal or I/O pull-up power supply may cause malfunction and the abnormal current that passes in the device at this time may cause degradation of internal elements. Follow the guideline for input signal during power-off state as described in your product documentation.

4. Handling of unused pins

Handle unused pins in accordance with the directions given under handling of unused pins in the manual. The input pins of CMOS products are generally in the high-impedance state. In operation with an unused pin in the open-circuit state, extra electromagnetic noise is induced in the vicinity of the LSI, an associated shoot-through current flows internally, and malfunctions occur due to the false recognition of the pin state as an input signal become possible.

5. Clock signals

After applying a reset, only release the reset line after the operating clock signal becomes stable. When switching the clock signal during program execution, wait until the target clock signal is stabilized. When the clock signal is generated with an external resonator or from an external oscillator during a reset, ensure that the reset line is only released after full stabilization of the clock signal. Additionally, when switching to a clock signal produced with an external resonator or by an external oscillator while program execution is in progress, wait until the target clock signal is stable.

6. Voltage application waveform at input pin

Waveform distortion due to input noise or a reflected wave may cause malfunction. If the input of the CMOS device stays in the area between V_{IL} (Max.) and V_{IH} (Min.) due to noise, for example, the device may malfunction. Take care to prevent chattering noise from entering the device when the input level is fixed, and also in the transition period when the input level passes through the area between V_{IL} (Max.) and V_{IH} (Min.).

7. Prohibition of access to reserved addresses

Access to reserved addresses is prohibited. The reserved addresses are provided for possible future expansion of functions. Do not access these addresses as the correct operation of the LSI is not guaranteed.

8. Differences between products

Before changing from one product to another, for example to a product with a different part number, confirm that the change will not lead to problems. The characteristics of a microprocessing unit or microcontroller unit products in the same group but having a different part number might differ in terms of internal memory capacity, layout pattern, and other factors, which can affect the ranges of electrical characteristics, such as characteristic values, operating margins, immunity to noise, and amount of radiated noise. When changing to a product with a different part number, implement a system-evaluation test for the given product.

CAUTION

This is a 'Class A' (CISPR11:2009+A1:2010) equipment. This equipment can cause radio frequency noise when used in the residential area. In such cases, the user/operator of the equipment may be required to take appropriate countermeasures under his responsibility.

CAUTION

This equipment should be handled like a CMOS semiconductor device. The user must take all precautions to avoid build-up of static electricity while working with this equipment. All test and measurement tool including the workbench must be grounded. The user/operator must be grounded using the wrist strap. The connectors and/or device pins should not be touched with bare hands.

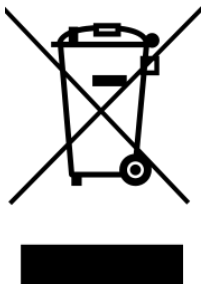
European Union Regulatory Notices:

The WEEE (Waste Electrical and Electronic Equipment) regulations put responsibilities on producers for the collection and recycling or disposal of electrical and electronic waste. Return of WEEE under these regulations is applicable in the European Union only. This equipment (including all accessories) is not intended for household use. After use the equipment cannot be disposed of as household waste, and the WEEE must be treated, recycled and disposed of in an environmentally sound manner. Renesas Electronics Europe GmbH can take back end of life equipment, register for this service at <http://www.renesas.eu/weee>

Disclaimer

By using this Renesas Solution Starter Kit (RSSK), the user accepts the following terms:

The RSSK is not guaranteed to be error free, and the entire risk as to the results and performance of the RSSK is assumed by the User. The RSSK is provided by Renesas on an “as is” basis without warranty of any kind whether express or implied, including but not limited to the implied warranties of satisfactory quality, fitness for a particular purpose, title and non-infringement of intellectual property rights with regard to the RSSK. Renesas expressly disclaims all such warranties. Renesas or its affiliates shall in no event be liable for any loss of profit, loss of data, loss of contract, loss of business, damage to reputation or goodwill, any economic loss, any reprogramming or recall costs (whether the foregoing losses are direct or indirect) nor shall Renesas or its affiliates be liable for any other direct or indirect special, incidental or consequential damages arising out of or in relation to the use of this RSSK, even if Renesas or its affiliates have been advised of the possibility of such damages.

Precautions

The following precautions should be observed when operating this RSSK:

This RSSK is only intended for use in a laboratory environment under ambient temperature and humidity conditions. A safe separation distance should be used between this and any sensitive equipment. Its use outside the laboratory, classroom, study area or similar such area invalidates conformity with the protection requirements of the Electromagnetic Compatibility Directive and could lead to prosecution.

The product generates, uses, and can radiate radio frequency energy and may cause harmful interference to radio communications. However, there is no guarantee that interference will not occur in a particular installation. If this equipment causes harmful interference to radio or television reception, which can be determined by turning the equipment off or on, you are encouraged to try to correct the interference by one or more of the following measures;

- ensure attached cables do not lie across the equipment
- reorient the receiving antenna
- increase the distance between the equipment and the receiver
- connect the equipment into an outlet on a circuit different from that which the receiver is connected
- power down the equipment when not in use
- consult the dealer or an experienced radio/TV technician for help NOTE: It is recommended that wherever possible shielded interface cables are used.

The product is potentially susceptible to certain EMC phenomena. To mitigate against them it is recommended that the following measures be undertaken;

- The user is advised to use the cable that is less than 3m in length to be connected to the product
- The user is advised that mobile phones should not be used within 10m of the product when in use.
- The user is advised to take ESD precautions when handling the equipment.

The RSSK does not represent an ideal reference design for an end product and does not fulfil the regulatory standards for an end product.

How to Use This Manual

1. Purpose and Target Readers

This manual is provided to help the users understand the outline and electrical characteristics of the board of Renesas Solution Starter Kit for RX23E-A (called "RSSKRX23E-A board" or "the board" below)

Although this manual contains an overview of the RSSKRX23E-A board functions, it is not written as a built-in programming or hardware design guide.

Particular attention should be paid to the precautionary notes when using RSSKRX23E-A board. These notes occur within the body of the text, at the end of each section, and in the Usage Notes section.

The revision history summarizes the locations of revisions and additions. It does not list all revisions. Refer to the text of the manual for details.

For Renesas Solution Starter Kit for RX23E-A the following documents are available. The newest versions of the documents listed may be obtained from the Renesas Electronics Web site.

Document Type	Description	Document Title	Document No.
User's Manual	Explanation of the RSSKRX23E-A board hardware specifications	RSSKRX23E-A User's Manual	R20UT4542EJ0110 (this document)
Quick Start Guide	Provides simple instructions to setup the RSSKRX23E-A board and run PC tool program	RSSKRX23E-A Quick Start Guide	R20QS0007EJ0100
PC Tool Program	Explanation of PC tool program that communicates with the RSSKRX23E-A board, sets the AFE/DSAD of RX23E-A, and obtains A/D conversion values	RSSKRX23E-A PC Tool Program Operation Manual	R20AN0540EJ0110

For specifications of RX23E-A: R5F523E6ADFL mounted on the board, the following documents are available. The newest versions of the documents listed may be obtained from the Renesas Electronics Web site.

User's Manual: Hardware	Explanation of RX23E-A hardware specifications (pin layout, memory map, peripheral function specifications, electrical characteristics, and timing) and operation * For details on how to use peripheral functions, refer to "Application Notes".	RX23E-A Group User's Manual: Hardware	R01UH0801EJ0100
-------------------------	--	---------------------------------------	-----------------

2. For Your Safety

Do not fail to read this manual before using the board

- Follow the indications in this manual when using the board
- Keep this manual near the board so you can refer to it whenever necessary.
- Transfer or sale of the board to third parties is prohibited without written approval.
- The purchaser or importer of the board is responsible for ensuring compliance with local regulations.



In addition, the customer is responsible for ensuring that the board is handled correctly and safely, in accordance with the laws of the customer's country (region).

- The manual for the board, and specification (the documents) are the tool that was developed for the function and performance evaluation of Renesas Electronics semiconductor device (Renesas Electronics device) mounted on the board, and not guarantee the same quality, function and performance.
- By purchasing the board or downloading the documents from Renesas Electronics website, the support services provided from Renesas Electronics is not guaranteed.
- All information contained in this manual represents information on products at the time of publication of this manual. Please note that the product data, specification, sales offices, contents of website, address, etc., are subject to change by Renesas Electronics Corporation without notice due to product improvements or other reasons. Please confirm the latest information on Renesas Electronics website.

Meaning of Notations

In this manual, items related to the safe use of the product are indicated as described below.

The degree of injury to persons or damage to property that could result if the designated content in this manual is not followed is indicated as follows.

 Warning	Indicates content that, if not followed, could result in death or serious injury to the user.
 Caution	Indicates content that, if not followed, could result in injury*1 to persons or physical damage.*2

Note 1. Injury refers to conditions for which treatment would necessitate hospitalization or regular hospital visits.

Note 2. Physical damage refers to damage affecting the wider surroundings, such as the user's home or property.

Requirements related to the handling of the product are classified into the following categories.



- Marks indicating that an action is prohibited.

	General Prohibition The indicated action is prohibited.
--	---

- Marks indicating that an action is alerted





	General Caution Indicates a general need for caution that is not specified.		Example: Caution - Static Electricity! Indicates the possibility of injury due to static electricity
---	---	---	--

- Marks directing that the specified action is required.





	General Instruction The specified action is required.		Example: Turn Off (Disconnect) Power Supply! Instructs the user to turn off (disconnect) the power supply to the product.
---	---	---	---

Warnings Regarding Use of the Product

■ Danger Items

 Warning	
	<p>Always insert plugs, connectors, and cables securely, and confirm that they are fully inserted.</p> <ul style="list-style-type: none"> • Incomplete connections could cause fire, burns, electric shock, or injury.
 	<p>Use the power supply apparatus specified in the manual.</p> <ul style="list-style-type: none"> • Failure to do so could cause fire, burns, electric shock, injury, or malfunction.
	<p>Disconnect the power supply and unplug all cables when the system will not be used for a period of time or when moving the system.</p> <ul style="list-style-type: none"> • Failure to do so could cause fire, burns, electric shock, or malfunction. • This will protect the system against damage due to lightning.
	<p>Use a mechanism (switch, outlet, etc.) located within reach to turn off (disconnect) the power supply.</p> <ul style="list-style-type: none"> • In case of emergency, it may be necessary to cut off the power supply quickly.
	<p>Turn off the power supply immediately if you notice abnormal odor, smoke, abnormal sound, or overheating.</p> <ul style="list-style-type: none"> • Continuing to use the system in an abnormal condition could cause fire, burns, or electric shock.
	<p>Do not integrate the product or any part of it into other equipment. Do not insert or remove cables or connectors when the product is powered on.</p> <ul style="list-style-type: none"> • The product has no safety case. • Failure to observe the above could cause fire, electric shock, burns, or malfunction. • The product may not perform as expected if used for other than its intended purpose.

■ Caution Items

 Caution	
	<p>Before modifying any part of this product, carefully check the manual.</p> <ul style="list-style-type: none"> • Incorrect modification or retrofitting may cause heat generation and device failures.
	<p>Follow the procedure specified in the manual when powering the system on or off.</p> <ul style="list-style-type: none"> • Failure to do so could cause overheating or malfunction.
	<p>Use the cable that is less than 3m in length to be connected to the product.</p> <ul style="list-style-type: none"> • Failure to do so could cause device failures or malfunction by external noise.
	<p>Caution – Static Electricity</p> <ul style="list-style-type: none"> • Use the antistatic band. Failure to do so could cause malfunction or unstable motion.

3.List of Abbreviations and Acronyms

Abbreviation	Full Form / Description
ADC	Analog to Digital Converter
AFE	Analog Front End
AMUX	Analog Multiplexer
BUF	Buffer Amplifier
CAN	Controller Area Network
CPU	Central Processing Unit
DSAD	Delta-Sigma Analog-to-Digital Converter
E2 Lite	Renesas On-chip Debugging Emulator
FW	Firmware
GUI	Graphical User Interface
I2C (IIC)	Philips™ Inter-Integrated Circuit Connection Bus
I/F	Interface
LDO	Low Dropout regulator
LED	Light Emitting Diode
LSW	Low Side Switch
MCU	Micro Controller Unit
NM	Not Mounted
PC	Personal Computer
PGA	Programmable Gain Amplifier
PROFIBUS DP	PROFIBUS Decentralized Peripherals
PWM	Pulse Width Modulation
RAM	Random Access Memory
ROM	Read Only Memory
RS-485	Recommended Standard 485
RTD	Resistance Temperature Detector
SARADC	Successive-Approximation-Register Analog-to-Digital Converter
SCI	Serial Communications Interface
SPI	Serial Peripheral Interface
UART	Universal Asynchronous Receiver/Transmitter
UM	User's Manual
USB	Universal Serial Bus

All trademarks and registered trademarks are the property of their respective owners.

Table of Contents

1. Overview.....	1
1.1 Purpose	1
1.2 Mounted MCU.....	1
1.3 Functions and Features	2
1.4 Specifications.....	3
1.5 System Block Diagram	4
1.6 Overview and Layout.....	5
2. Using the RSSKRX23E-A Board.....	6
2.1 Operating Conditions.....	6
2.2 Selecting Power Supplies	7
2.3 Connecting a PC to the Board	8
2.4 Using the Analog Input Circuit.....	9
2.4.1 Overview of the Analog Input Circuit.....	9
2.4.2 DSAD Measurement Circuit	11
2.4.3 Thermocouple Measurement Circuit	12
2.4.4 Reference Junction Compensation Circuit Using the On-Board RTD	13
2.4.5 Four-Wire RTD Measurement Circuit.....	14
2.4.6 Three-Wire RTD Measurement Circuit	15
2.4.7 Strain Gage Measurement Circuit	16
2.4.8 Handling Unused Pins in the Analog Input Circuit	18
3. Microcontroller Peripheral Circuits	19
3.1 USB Serial Communication Circuit.....	19
3.2 Emulator Peripheral Circuit.....	20
3.3 RS-485 Communication Circuit.....	21
3.4 CAN Communication Circuit.....	21
3.5 LED Circuit	22
3.6 Switch Input Circuit	22
3.7 External Clock Input Circuit	23
4. Board Information	24
4.1 Using Terminal Blocks.....	24
4.2 Connectors.....	25
4.3 Pin Headers for Communication Interfaces	29

4.4	Jumper Pins	30
4.5	Universal Through-Holes	33
4.6	Through-Hole Taps	36
4.7	Test Points	36
4.8	Short Pads.....	37
4.9	Initial Settings of MCU Pins	38
Appendix		i
Appendix 1. Board Diagrams		i
Appendix 2. Circuit Diagram.....		iv
Appendix 3. Parts List.....		vi

RSSKRX23E-A

Renesas Solution Starter Kit for RX23E-A

1. Overview

1.1 Purpose

The board of Renesas Solution Starter Kit for RX23E-A (called “RSSKRX23E-A board” or “the board” below) is an evaluation tool for the Renesas microcontroller RX23E-A. This manual describes the hardware aspect of the RSSKRX23E-A board in detail. The manual also describes how to connect the board to a PC and sensors for evaluation.

1.2 Mounted MCU

Table 1-1 lists the specifications of the MCU mounted on the board. The RX23E-A MCU mounted on the board contains two low-noise 24-bit Δ - Σ A/D converters (DSADs). A DSAD contains a programmable gain instrumentation amplifier (PGA). The gain can be selected from x1, x2, x4, x8, x16, x32, x64, and x128. It also contains an analog front-end (AFE) circuit suitable for measuring sensors such as a thermocouple, RTD, and strain gage. Up to 6 channels of measurement can be performed by switching the analog multiplexer (AMUX) in the AFE.

For details on the MCU operating conditions, and DSAD and AFE settings, refer to “RX23E-A Group User's Manual: Hardware”.

Table 1-1 Mounted MCU

Product group	RX23E-A
MCU model name	R5F523E6ADFL
Maximum CPU operating frequency	32 MHz
Number of bits	32
Package/number of pins	LFQFP/48
ROM	256 KB
RAM	32 KB
Operating temperature range	-40 to +85°C
Storage temperature range	-55 to +125°C

1.3 Functions and Features

The board has the following functions and features.

(1) Functions and features for hardware and system design engineers

- A/D converter evaluation circuit
- Thermocouple measurement circuit
- Resistance temperature detector (RTD) measurement circuit
- Strain gage measurement circuit
- Power supply selection circuit
- FW controlling DSAD and AFE operation
- Transmission of measurement results and reception of AFE settings using USB communication

(2) Functions and features for software design engineers

- RX23E-A programming and debugging
- Switches, LEDs, and other user interfaces

The board has all circuits required for microcontroller operation.

1.4 Specifications

Table 1-2 Specifications of the RSSKRX23E-A Board

Item		Specification	
Board model name		RTK0ESXB10C00001BJ	
MCU input clock		8-MHz external crystal oscillator	
Applicable emulator		E1, E2, and E2 Lite	
Power input terminal block		CN4: System power input terminal block (2-pin) CN5: Analog power input terminal block (2-pin)	
Signal input terminal block		CN2: Signal input terminal block (13-pin)	
Analog power output terminal block		CN1: Analog power output terminal block (2-pin)	
Thermocouple connector		CN3: Miniature thermocouple socket (2-pin) Material: copper-copper	
Emulator connector		CN7: 14-pin interface connector	
On-board RTD		Pt100 Class F0.3 (Class B) Model: PTS060301B100RP100	
Communication interfaces	USB	Connector	CN6: USB serial communication connector USB mini-B
		Driver	U3: FT232RL
	CAN	Connector	J6: Pin header (3-pin 2.54mm pitch)
		Driver	U5: R2A25416SP
	RS-485	Connector	J7: Pin header (3-pin 2.54mm pitch)
		Driver	ISL3159EFUZ
On-board LDO	Model	ISL80410IBEZ	
	Device specifications	Operating voltage range: 6 to 40 V (Note) Output setting: 5 V (2.5 to 12 V variable output)	
User interfaces	LEDs	LED2: Power LED (VCC) Color: Green	
		LED1: User LED (PH2) Color: Red	
	Switches	SW1: User switch SW2: External MCU reset switch	
Universal through-holes		2.54-mm pitch J1: 4-pin through holes J2: 12-pin through holes J3, J4: 10-pin through holes	
Board outline		120mm x 92mm	
Operating temperature		Room temperature	
Operating humidity		No condensation allowed	

Note When the on-board LDO is used, the operating voltage range of this product is 6.5 to 12 V due to limitations of peripheral components.

1.5 System Block Diagram

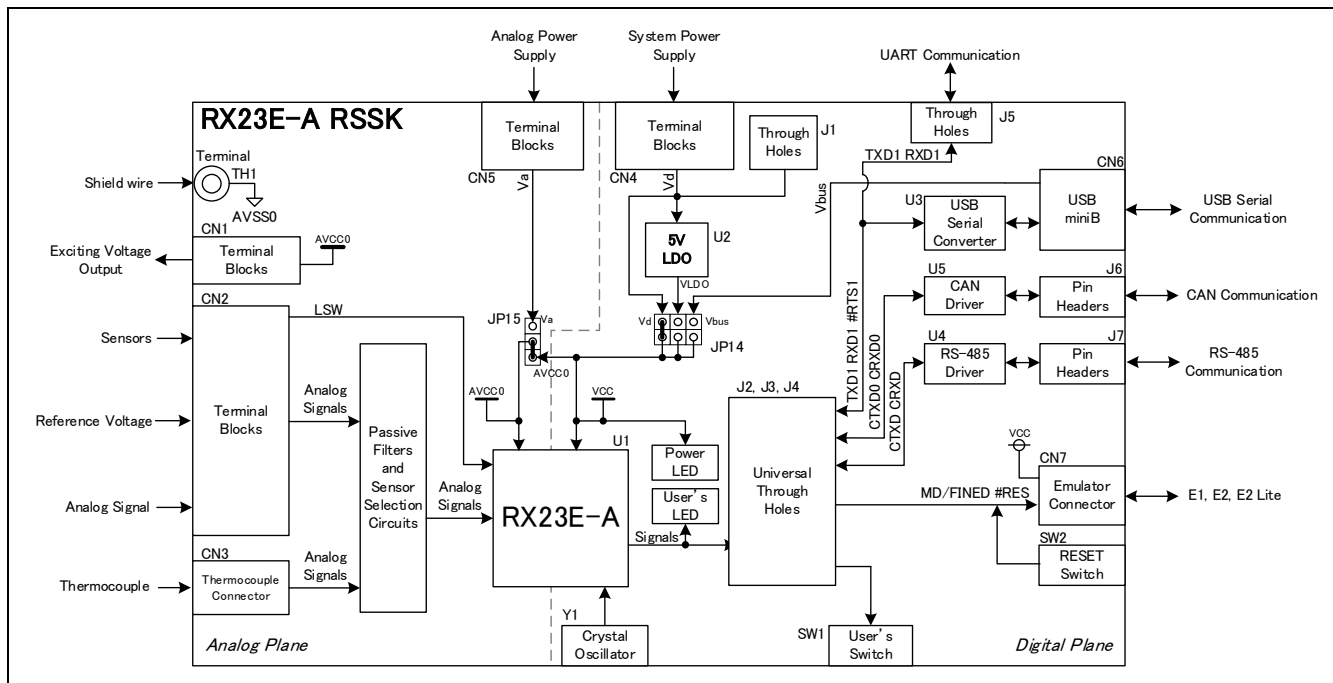

Figure 1-1 RSSKRX23E-A Board System Block Diagram

1.6 Overview and Layout

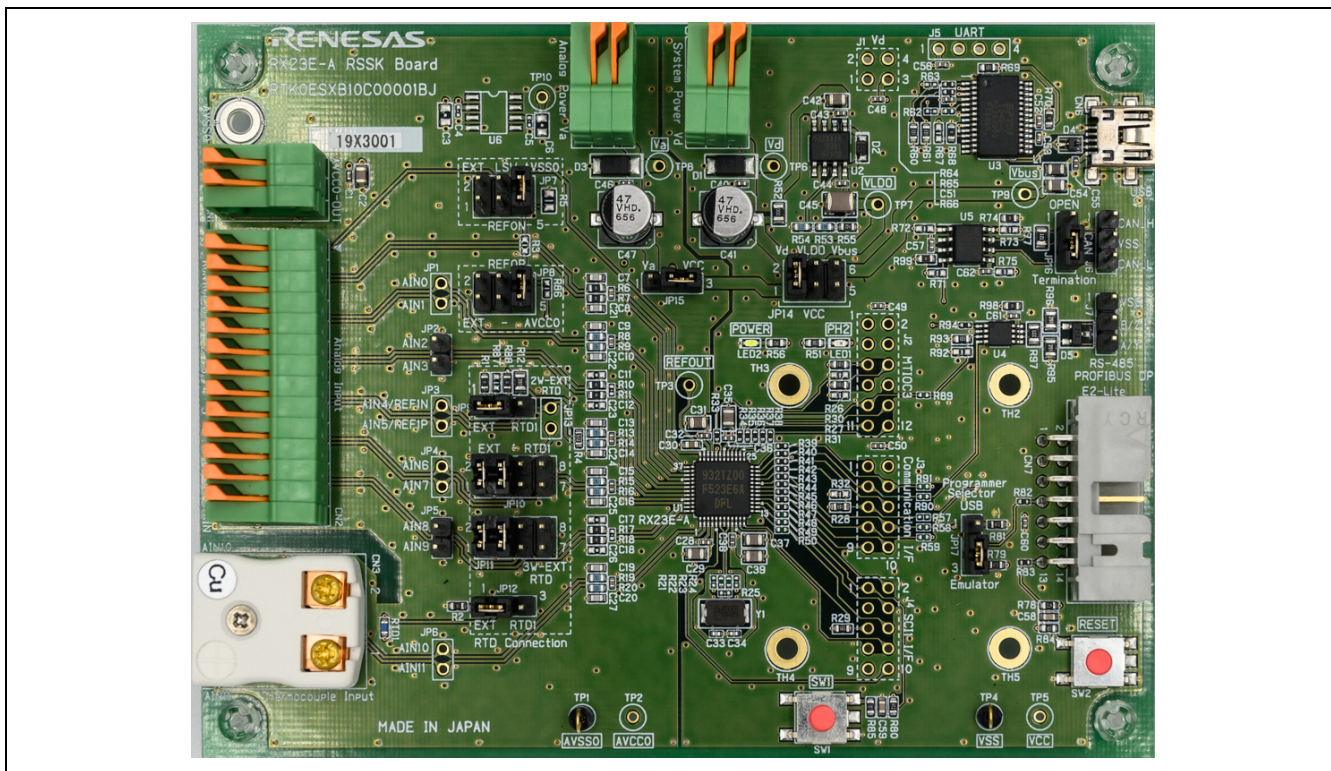

Figure 1-2 Overview of the RSSKRX23E-A Board (Front Side)

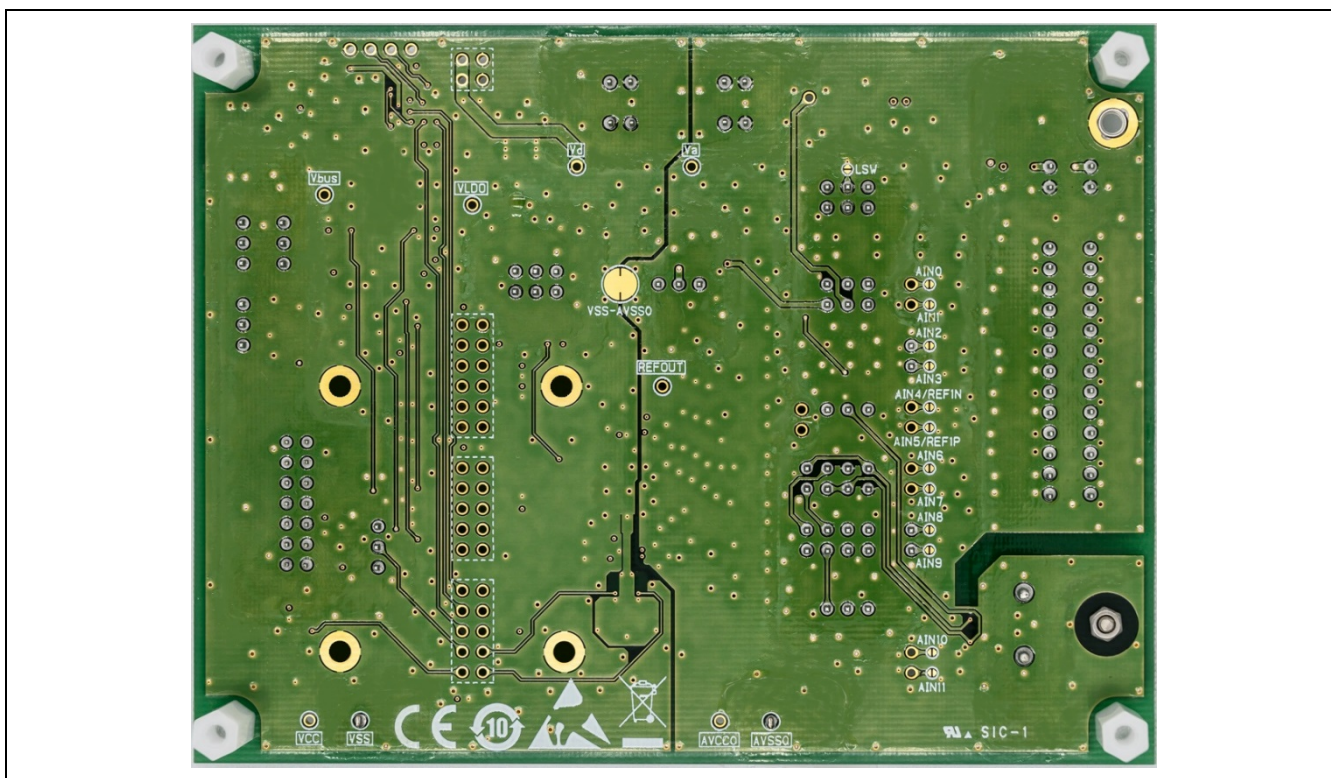

Figure 1-3 Overview of the RSSKRX23E-A Board (Back Side)

2. Using the RSSKRX23E-A Board

2.1 Operating Conditions

Table 2-1 lists the recommended operating conditions of the board.

Observe the recommended operating conditions when using the board. The use of the board without observing any recommended operating condition may cause unpredictable operation. The use of the board without observing any maximum rating may cause a failure or damage to the board.

Table 2-1 Recommended Operating Conditions

Condition: VSS = AVSS0 = 0 V

Item	Symbol	Input pin	Recommended operating range	Maximum rating	Condition
System power supply	Vd (VCC)	CN4	4.5 to 5.25 V (Note 1)	6.0 V	When the LDO is not used (when pins 1-2 or 5-6 of JP14 are connected) (Note 5)
	Vd		6.5 to 12 V (Note 2)	20 V	When the LDO is used (when pins 5-6 of JP14 are connected)
Analog power supply	AVCC0	CN5	2.7 to 5.5 V (Note 3)	6.5 V	When analog and digital power supplies are separated (when pins 1-2 of JP14 are connected) and VCC > 2.7 V
Digital pin	V _{IN}	See Section 4.5.	-0.3 to VCC + 0.3		Absolute maximum rating
Analog pin	V _{AIN}	CN2 (R0P, R0N, 0~9)	-0.3 to AVCC0 + 0.3		Absolute maximum rating
		CN3 (AN10, AN11)			
LSW pin	I _{LSW}	CN2 (LSW, R0N (Note 4))	—	30 mA	When the LSW is switched ON

Note 1. Operation of USB serial communication, CAN communication, and RS-485 communication are guaranteed only in condition of inside recommended operating range (4.5~5.25V). RX23E-A can operate at 1.8 to 5.5 V.

Note 2. Although the operating voltage of the LDO (ISL80410) is 6 to 40 V, the recommended LDO operating range on the board is 6.5 to 12 V, considering the capacitor rated voltage, power line voltage drop, and heat generation of the LDO.

Note 3. Supply the power to VCC and AVCC0 simultaneously or sequentially in this order.

Note 4. The R0N pin is connected to the LSW pin when pins 3 and 4 of JP7 are connected.

Note 5. When pins 1 and 2 are connected, Vd is directly connected to VCC.
When pins 5 and 6 are connected, VBUS (USB power supply) is connected to VCC.

2.2 Selecting Power Supplies

Figure 2-1 shows the power supply configuration of the board. Table 2-2 shows how to select each power supply on the board. Before using a combination of power supplies not listed in Table 2-2, carefully check the recommended operating conditions in Table 2-1.

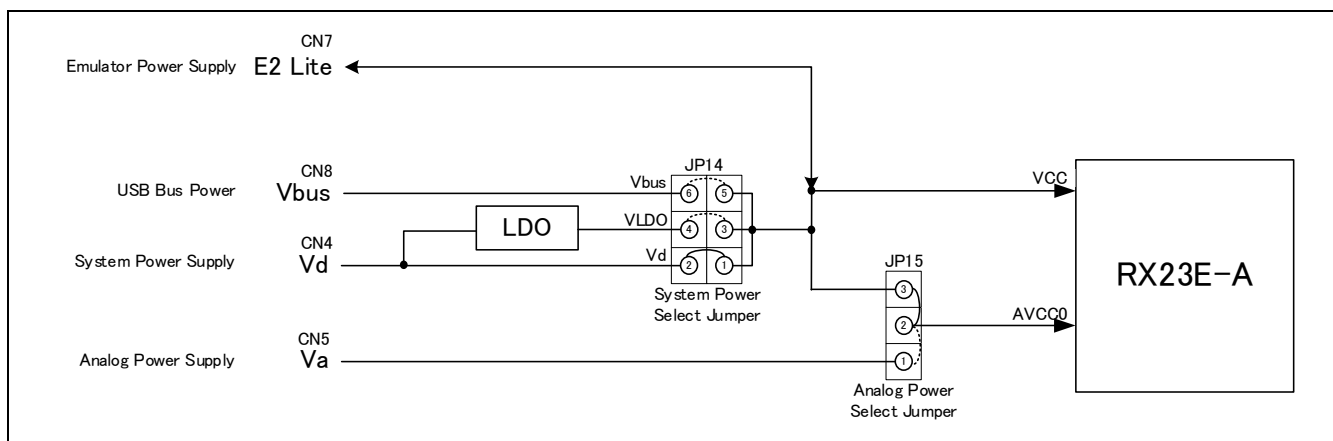

Figure 2-1 Power Supply Configuration of the RSSKRX23E-A Board

Table 2-2 Power Selection Methods

Input power supply	Digital power supply VCC	Analog power supply AVCC0	JP14 connection	JP15 connection	Remarks
Vd	Vd	Vd	Pins 1-2	Pins 2-3 (Note 1)	Initial default setting
	Vd	Va	Pins 1-2	Pins 1-2	Separate analog/digital power supplies
	VLDO	VLDO	Pins 3-4	Pins 2-3 (Note 1)	
Vbus	Vbus	Vbus	Pins 5-6	Pins 2-3 (Note 1)	USB operation for simple check
Emulator	Emulator	Emulator	Pins 1-2 (Note 2)	Pins 2-3 (Note 1)	Do not supply the power to Vd or Vbus.
	Emulator	Va	Pins 1-2 (Note 2)	Pins 1-2	Do not supply the power to Vd or Vbus.

Note 1. **When connecting pins 2 and 3 of JP15, do NOT supply the power to Va.** If the power is supplied to Va, VCC and AVCC0 are connected on the board, resulting in a short-circuit between Va and VCC.

Note 2. The emulator power supply is connected to VCC. **If pins 3 and 4 of JP14 are left connected and the power is supplied from the emulator, voltage is applied to the output of U2 and U2 may be damaged. Never supply the power from the emulator when the pins are connected.**

2.3 Connecting a PC to the Board

Figure 2-2 shows a configuration used when a PC is connected to the board. Table 2-3 lists functions available when a PC is connected to the board.

When connecting a PC to the board, supply the power to the board as described in "2.2 Selecting Power Supplies".

The board can be connected to the Renesas on-chip debugging emulator (E1, E2, E2 Lite) to debug user code. When using the emulator, connect the 14-pin interface cable attached with the emulator to CN7. **Before supplying the power from the emulator, check that the following conditions are satisfied. If any of the conditions is not satisfied, a failure may occur in the board, power supply, and/or emulator.**

- **The power is NOT supplied to VCC.**
- **Pins 3 and 4 of JP14 are NOT connected.**

3.3-V power is supplied from E2 Lite. Note that USB serial communication, RS-485 communication, and CAN communication do not operate. When using the emulator, refer to the user's manual of the emulator.

The board contains a USB serial conversion IC. SCI1 interface of the MCU and USB serial conversion IC are connected and communication with a PC is available by USB serial communication. To use USB serial communication, connect a USB cable to CN6 (USB mini-B connector).

For details on PC Tool Programs, refer to the "RSSKRX23E-A PC Tool Program Operation Manual".

For details on the circuits around CN6 and CN7, see "3.1 USB Serial Communication Circuit" and "3.2 Emulator Peripheral Circuit".

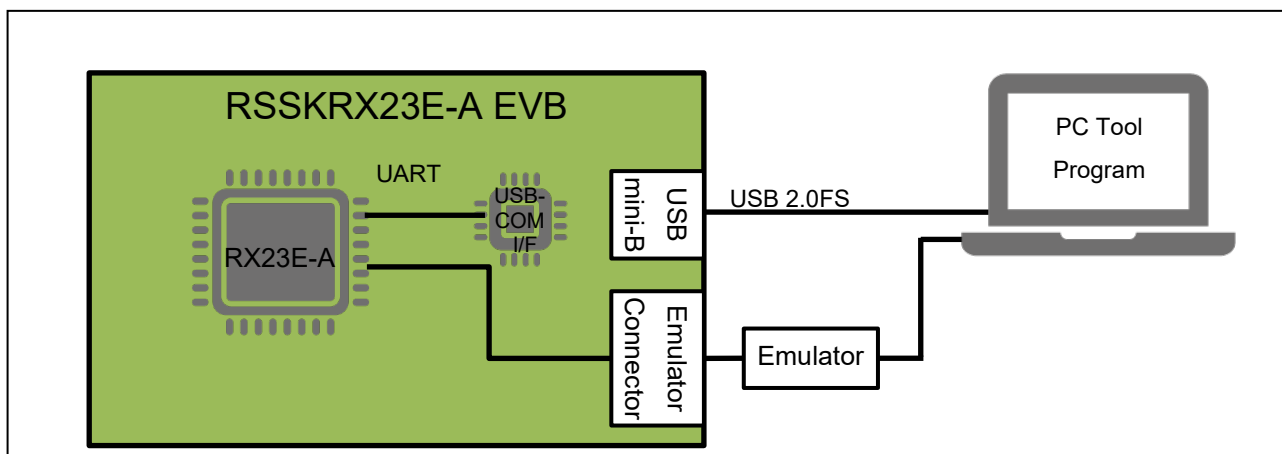

Figure 2-2 Connecting a PC

Table 2-3 Functions Available When a PC Is Connected

Item	Connected to	JP17 connection and function	
		When pins 1-2 are connected	When pins 2-3 are connected
Emulator	CN7	Disabled	Code debugging FW write via the FINE interface
USB serial communication	CN6	FW write via the SCI interface	Communication with PC Tool Program

2.4 Using the Analog Input Circuit

2.4.1 Overview of the Analog Input Circuit

The analog input circuit on the board has the following functions.

- DSAD measurement circuit
- Thermocouple measurement circuit
- Reference junction compensation circuit using the on-board RTD
- Four-wire RTD measurement circuit
- Three-wire RTD measurement circuit
- Strain gage measurement circuit

This manual covers the circuit configuration required for implementing each function and the relationship between the DSAD measurement result and input signal in two's complement format. For details on processing for converting the DSAD measurement result to a physical quantity, refer to the application notes related to sensor measurement.

To switch the function, it is necessary to change the jumper pin connection and DSAD and AFE settings. The jumper pin connection and built-in FW are factory-set for the DSAD measurement circuit using AIN3 and AIN2 or AIN9 and AIN8.

Table 2-4 lists each function of the analog input circuit and corresponding jumper pin connection. Table 2-5 lists factory settings of the DSAD and AFE.

Table 2-4 Functions of the Analog Input Circuit and Corresponding Jumper Settings

Connection Function	Jumper pin connection						Used pins of the MCU (pin function)		
	JP7	JP8	JP9	JP10	JP11	JP12	Positive side input	Negative side input	Others
Factory settings	5-6	5-6	1-2	1-2 and 3-4	1-2 and 3-4	1-2	N/A	N/A	N/A
DSAD measurement circuit	X	X	X	X	X	X	AIN3	AIN2	N/A
	X	X	X	X	1-2 and 3-4	1-2	AIN9	AIN8	N/A
Thermocouple measurement circuit	X	X	X	X	X	X	AIN11	AIN10	N/A
Reference junction compensation circuit	X	X	2-3	5-6 and 7-8	1-2 and 3-4	2-3	AIN7	AIN6	AIN4(REF1N) AIN5(REF0N) AIN9(IEXC)
Three-wire RTD measurement circuit	X	X	1-2	1-2 and 3-4	5-6 and 7-8	1-2	AIN7	AIN6	AIN4(REF1N) AIN5(REF1P) AIN8(IEXC) AIN9(IEXC)
Four-wire RTD measurement circuit	X	X	1-2	1-2 and 3-4	1-2 and 3-4	1-2	AIN7	AIN6	AIN4(REF1N) AIN5(REF1P) AIN9(IEXC)
Strain gage measurement circuit	3-4 or 5-6	5-6	X	X	X	X	AIN1	AIN0	REF0N, REF0P

X: Don't care N/A: Not applicable

Note The thermocouple measurement circuit is independent of the JP7 to JP12 jumper pin connection.

Table 2-5 Factory Settings of the DSAD and AFE

Item	Symbol	Setting value			Remarks
		Polarity	DSAD0	DSAD1	
Measurement pin	—	Positive	AIN3	AIN9	Directly connected to the DSAD (Both the PGA and buffer amplifier are bypassed)
		Negative	AIN2	AIN8	
Reference voltage	VREF	Positive	REFOUT	REFOUT	Internal reference voltage used. REFOUT: 2.5 V _{typ} .
		Negative	AVSS0	AVSS0	
Gain	GAIN	—	1x	1x	
Data rate	DR	—	976.563 SPS	976.563 SPS	Oversampling ratio: 512

Note The bias voltage generator and excitation current source are not used in the factory setting.

2.4.2 DSAD Measurement Circuit

Figure 2-3 shows an example usage of the DSAD measurement circuit on the board.

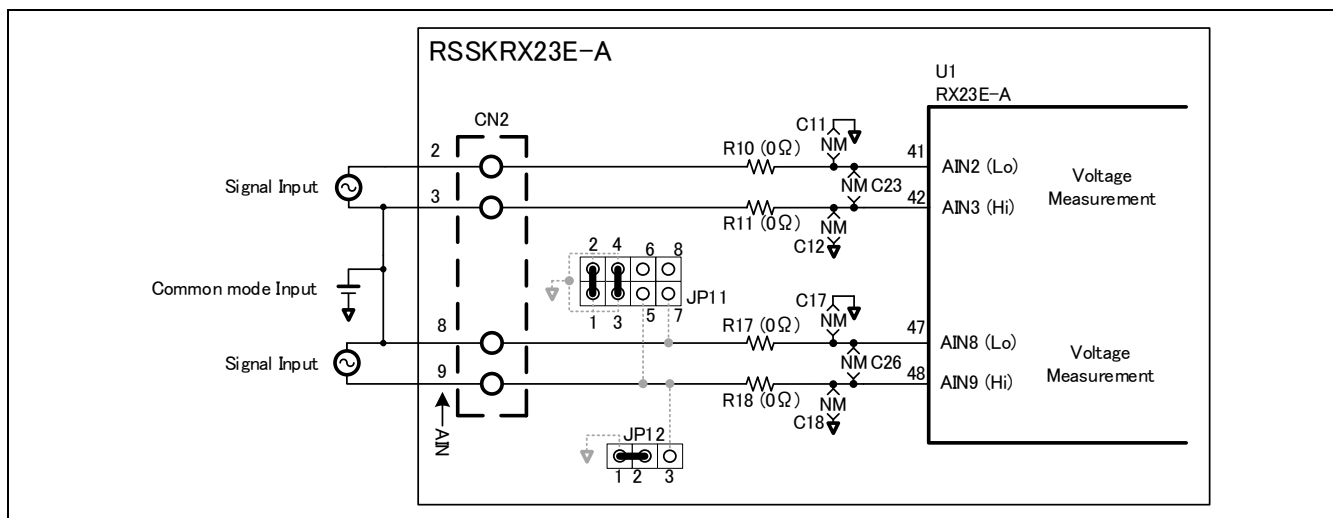

Figure 2-3 Example Usage of DSAD Measurement Circuit

The FW built onto the board at shipment is set to measure the differential voltage between AIN3 and AIN2 and that between AIN9 and AIN8 using two channels DSAD0 and DSAD1 in the MCU. The input voltage between pins 3 and 2 of CN2 (between AIN3 and AIN2) and between pins 9 and 8 of CN2 (between AIN9 and AIN8) are being used for the measurement. The differential input voltage V_{ID} can be obtained from the DSAD measurement result AD_{DATA} using the following expression.

$$V_{ID} = \frac{V_{REF} \times 2}{GAIN} \times \frac{AD_{DATA}}{2^{24}} [V]$$

Before applying voltage to the DSAD measurement circuit, check the following conditions. If either condition is not satisfied, measurement cannot be performed correctly.

- (1) The voltage between each AIN and AVSS0 is within the absolute input voltage range for DSAD measurement.
- (2) The voltage between AIN pins is within the differential voltage input range.

The absolute input voltage range and differential voltage input range depend on the DSAD settings. For details, refer to "RX23E-A Group User's Manual: Hardware".

During evaluation with the DSAD measurement circuit, self-noise of the DSAD and PGA can be measured by short-circuiting input pins using JP2 and JP5. To short-circuit input pins, fix the input pin potential to satisfy condition (1). The PGA input bias current may cause the input pin potential to be outside the absolute input voltage range. Sample methods for fixing the input pin potential are listed below.

- (a) Connect an external stable potential to one measurement pin.
- (b) Connect one measurement pin to GND via a resistor.
- (c) Apply bias voltage to one measurement pin using the AFE bias voltage generator.

When using method (a) or (b) for measurement, check that the applied voltage is within the range of condition (1). Depending on connection, the differential input impedance becomes imbalanced, and the circuit may be susceptible to common mode noise.

2.4.3 Thermocouple Measurement Circuit

Figure 2-4 shows the thermocouple measurement circuit on the board.

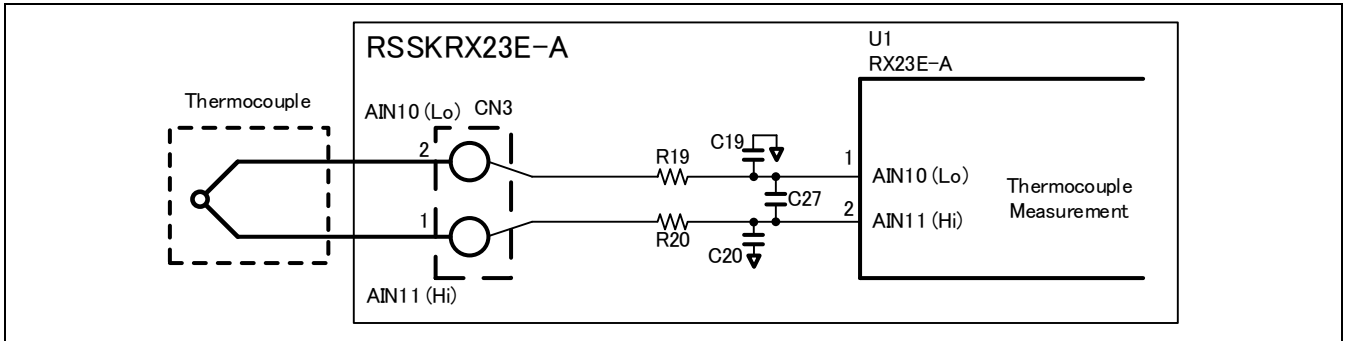

Figure 2-4 Thermocouple Measurement Circuit

CN3 is a connector socket on board the RSSKRX23E-A (material : copper-copper) used for the thermocouple input pins. Thermocouple attached with the board can be connected to CN3 for measurement.

Connect the positive side of the thermocouple to AIN11 pin of CN3 and the negative side to AIN10 pin. The output from the thermocouple (thermoelectromotive force) is input to AIN11 and AIN10 and the differential voltage between AIN11 and AIN10 is measured with the DSAD. The thermoelectromotive force V_{TEMP} can be obtained from the DSAD measurement result AD_{DATA} using the following expression.

$$V_{TEMP} = \frac{V_{REF} \times 2}{GAIN} \times \frac{AD_{DATA}}{2^{24}} [V]$$

For thermocouple measurement, fix the input pin potential. The PGA input bias current may cause the input pin potential to be outside the absolute input voltage range.

Measuring a temperature with the thermocouple requires cold junction compensation or reference junction compensation. The board enables reference junction compensation using the on-board RTD. For details on the reference junction compensation circuit using the on-board RTD, see 2.4.4 “Reference Junction Compensation Circuit Using the On-Board RTD”

2.4.4 Reference Junction Compensation Circuit Using the On-Board RTD

Figure 2-5 shows the reference junction compensation circuit on the board.

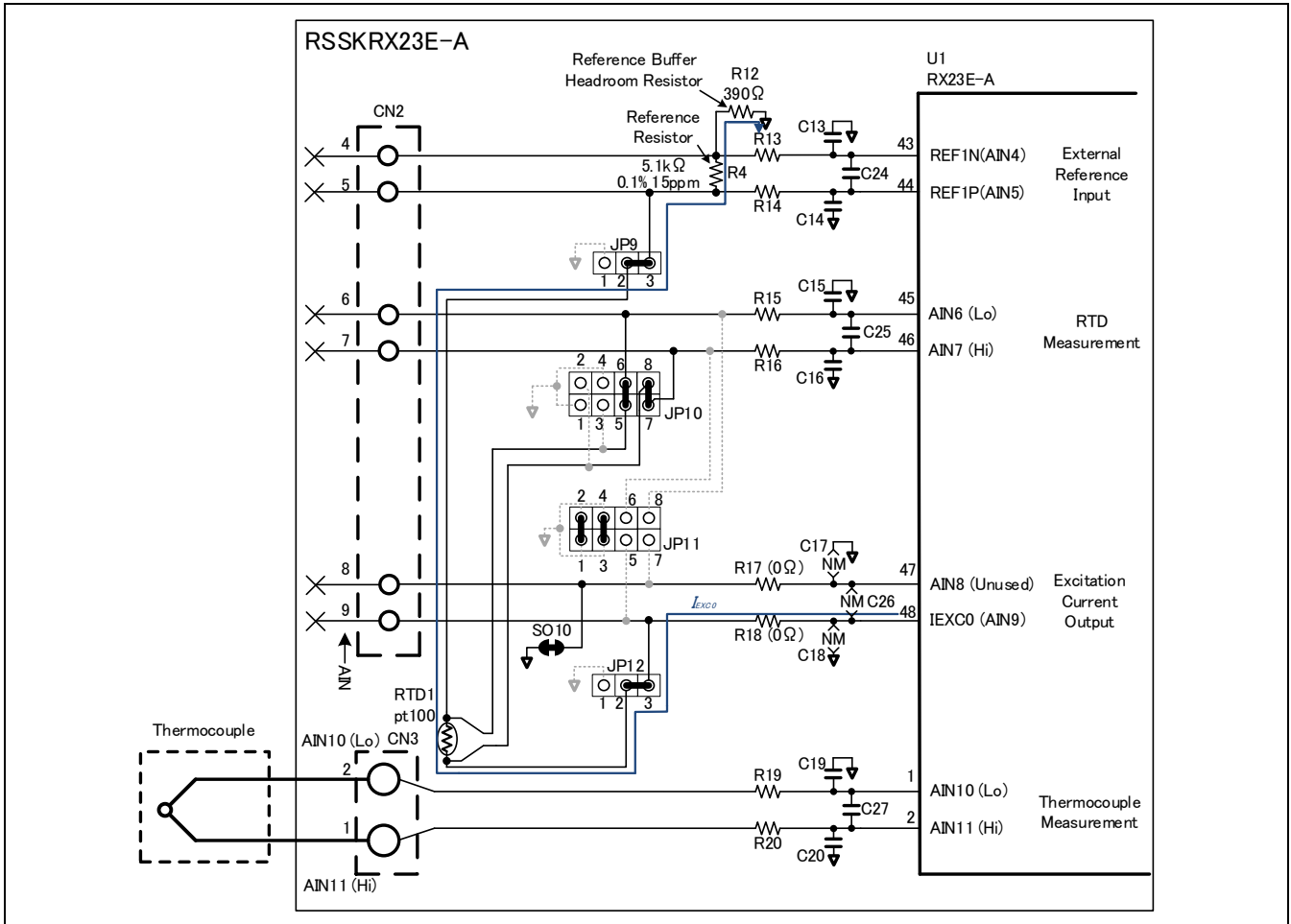

Figure 2-5 Reference Junction Compensation Circuit

On the board, the temperature near CN3 is detected with the on-chip resistance temperature detector, RTD1, for reference junction compensation for thermocouple measurement. For RTD1 measurement, a four-wire ratiometric measurement method is used. The excitation current I_{EXCO} is output from AIN9 and is made to flow in the path shown by the arrow. The voltages at both ends of RTD1 are input to AIN7 and AIN6 and they are measured with the DSAD. The voltages at both ends of the reference resistor R4 are input to REF1P (AIN5) and REF1N (AIN4) and used as DSAD external reference voltages. The RTD1 resistance can be indicated using the DSAD measurement result AD_{DATA} as shown below.

$$I_{EXCO} \times RTD1 = \frac{I_{EXCO} \times R_4 \times 2}{GAIN} \times \frac{AD_{DATA}}{2^{24}} [V]$$

When I_{EXCO} is deleted from both sides,

$$RTD1 = \frac{R_4 \times 2}{GAIN} \times \frac{AD_{DATA}}{2^{24}} [\Omega]$$

With the above expression, the RTD1 resistance can be obtained independently of the excitation current I_{EXCO} . Use a built-in reference buffer (RBUF) with AFE for external reference inputs REF1N and REF1P. The use of the RBUF can reduce the current input to the external reference input pin. Note that the use of the RBUF narrows the absolute input voltage range for external reference. R12 is provided to make the voltages at both ends of R4 fall within the absolute input voltage range for external reference when the RBUF is used.

2.4.5 Four-Wire RTD Measurement Circuit

Figure 2-6 shows the four-wire RTD measurement circuit on the board.

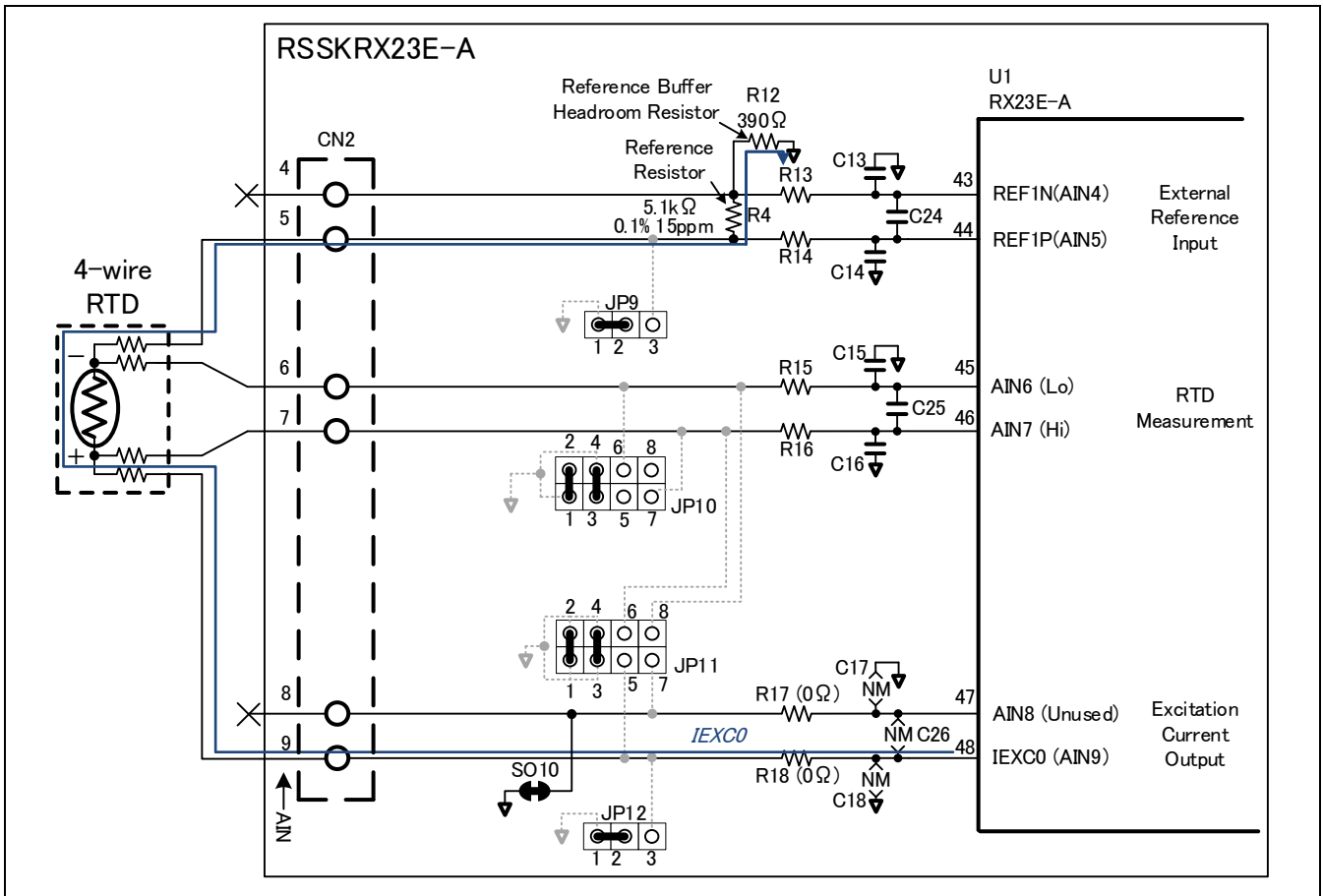

Figure 2-6 Four-Wire RTD Measurement Circuit

A configuration similar to that for on-board RTD measurement is used for four-wire RTD measurement. Connect two pins of same polarity of a four-wire RTD to pins 9 (AIN9) and 7 (AIN7) of CN2 and two pins of the other polarity to pins 6 (AIN6) and 5 (AIN5) of CN2. The excitation current I_{EXC0} is output from AIN9 and is made to flow in the path shown by the arrow. The voltages at both ends of the RTD are input to AIN7 and AIN6 as detection signals and they are measured with the DSAD. The voltages at both ends of the reference resistor R4 are input to REF1P (AIN5) and REF1N (AIN4) and used as DSAD external reference voltages. The RTD resistance RTD_{4-wire} can be indicated using the DSAD measurement result AD_{DATA} as shown below.

$$I_{EXC} \times RTD_{4-wire} = \frac{I_{EXC} \times R_4 \times 2}{GAIN} \times \frac{AD_{DATA}}{2^{24}} [V]$$

When I_{EXC0} is deleted from both sides,

$$RTD_{4-wire} = \frac{R_4 \times 2}{GAIN} \times \frac{AD_{DATA}}{2^{24}} [\Omega]$$

With the above expression, the RTD resistance RTD_{4-wire} can be obtained independently of the excitation current I_{EXC0} .

In the same way as for on-board RTD measurement, RBUF is used for external reference input.

2.4.6 Three-Wire RTD Measurement Circuit

Figure 2-7 shows the three-wire RTD measurement circuit on the board.

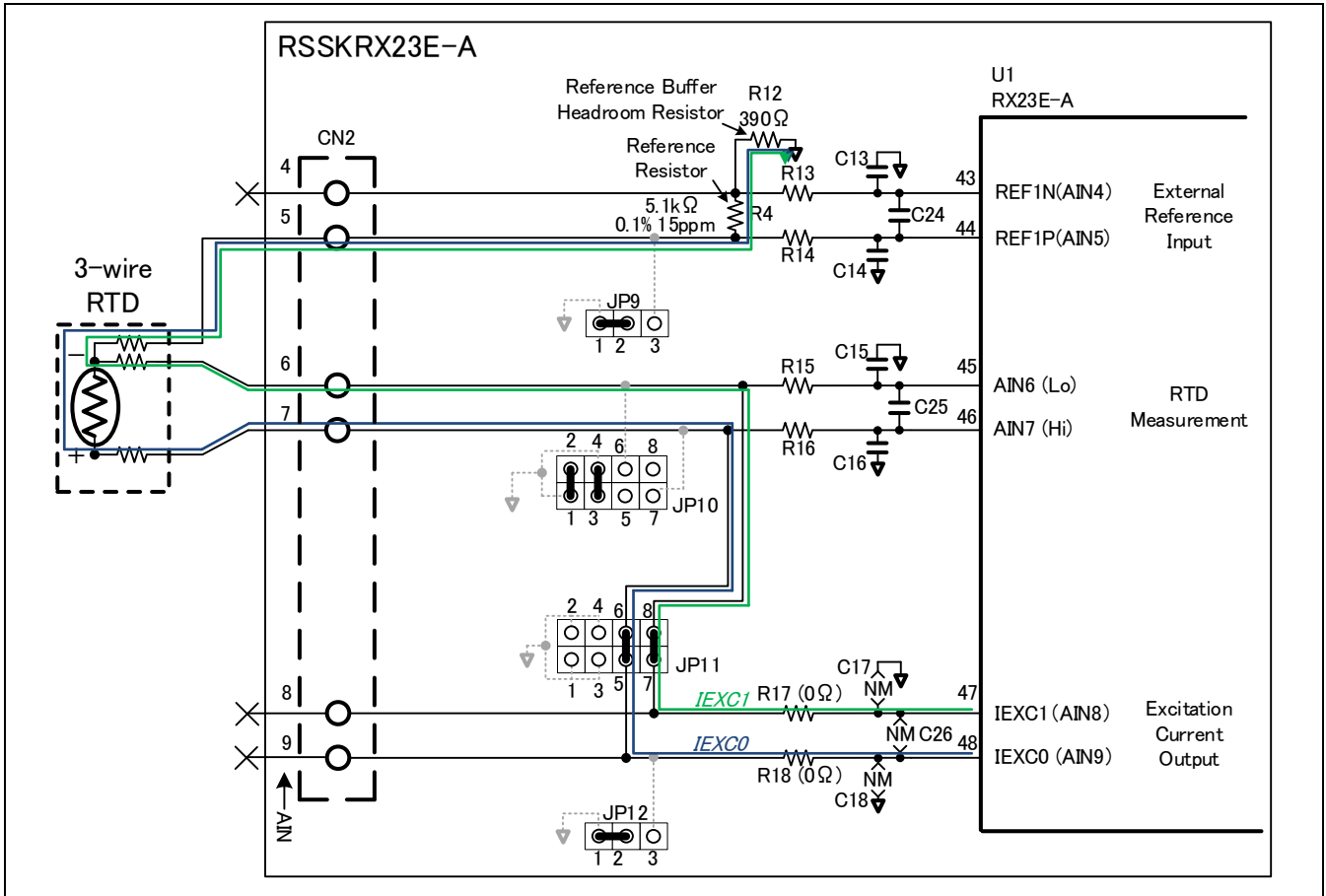

Figure 2-7 Three-Wire RTD Measurement Circuit

Connect one pin at one side of a three-wire RTD to pin 7 (AIN7) of CN2 and two pins of the other polarity to pins 6 (AIN6) and 5 (AIN5) of CN2. The excitation currents I_{EXC1} and I_{EXC0} are output from AIN8 and AIN9 and are made to flow in the path shown by the arrow. The voltages at both ends of the RTD are input to AIN7 and AIN6 as detection signals and they are measured with the DSAD. The voltages at both ends of the reference resistor R4 are input to REF1P (AIN5) and REF1N (AIN4) and used as DSAD external reference voltages. The RTD resistance RTD_{3-wire} is indicated using the DSAD measurement result AD_{DATA} as shown below.

$$I_{EXC0} \times RTD_{3-wire} = \frac{(I_{EXC0} + I_{EXC1}) \times R_4 \times 2}{GAIN} \times \frac{AD_{DATA}}{2^{24}} [V]$$

When $I_{EXC0} = I_{EXC1}$, $I_{EXC0} + I_{EXC1} = 2 \times I_{EXC0}$. When I_{EXC0} is deleted from both sides,

$$RTD_{3-wire} = \frac{R_4 \times 4}{GAIN} \times \frac{AD_{DATA}}{2^{24}} [\Omega]$$

With the above expression, when the excitation currents I_{EXC0} and I_{EXC1} are equal, the RTD resistance RTD_{3-wire} can be obtained independently of the excitation currents.

In the same way as for on-board RTD and four-wire RTD measurement, RBUF is used for external reference input.

2.4.7 Strain Gage Measurement Circuit

Figure 2-8 shows the measurement circuit for a strain gage (four-wire, single-gage method) on the board.

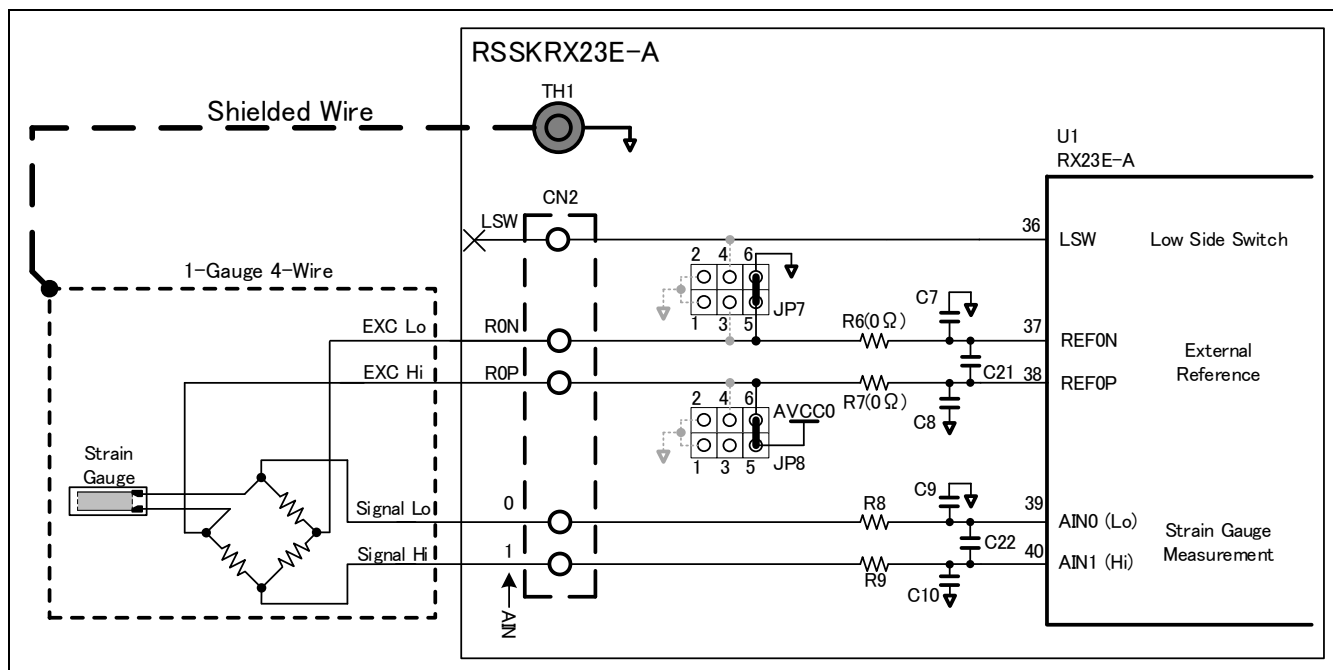

Figure 2-8 Strain Gage (Four-wire, Single-gage Method) Measurement Circuit

For the board, as an example of strain gage measurement, a measurement circuit for the four-wire, single-gage method using a Wheatstone bridge is used.

Connect a strain gage that configured a bridge circuit to R0N pin (REF0N), R0P pin (REF0P), pin 0 (AIN0), and pin 1 (AIN1) of CN2. Use AVCC0 and AVSS0 as excitation voltage sources to drive the bridge circuit. The voltages of the output pins of the strain gage are input to AIN0 and AIN1 and the differential voltage is measured with the DSAD. AVCC0 and AVSS0 are used as external reference inputs. When the strain gage has a shielded wire, it can be connected to TH1 or the negative pin of CN1.

As an external reference input, LSW can be connect instead of AVSS0. The LSW pin is connected to AVSS0 via an analog switch in the MCU. This switch can be changed according to the MCU register setting. Power supply to the strain gage can be supplied by turning on the switch, and power supply to the strain gage can be stopped by turning off the switch. Supplying the power to the strain gage only during measurement can reduce power consumption. **The allowable current to the LSW pin is 30 mA. When using the LSW pin, consider the allowable current.**

If the LDO is used as the power supply for strain gage measurement (by connecting pins 3 and 4 of JP14), be careful about the LDO output current. **The maximum output current of the LDO mounted on the board, ISL80410, is 150 mA. If current exceeding the maximum output current is required, do not use the LDO.**

In this circuit, the relationship between the differential voltage between AIN0 and AIN1 V_{strain} and strain ratio ε can be indicated using the gage coefficient K (strain gage sensitivity) as shown below.

$$V_{strain} = \frac{1}{4} \times K \times \varepsilon \times (AVCC0 - AVSS0)[V]$$

The differential voltage V_{strain} can be indicated using the DSAD measurement result AD_{DATA} with the following expression.

$$V_{strain} = \frac{2 \times (AVCC0 - AVSS0)}{GAIN} \times \frac{AD_{DATA}}{2^{24}}$$

When V_{strain} , $AVCC0$, and $AVSS0$ are deleted from the above two expressions, the strain ratio ε can be indicated with the following expression.

$$\varepsilon = \frac{2 \times 4}{K \times GAIN} \times \frac{AD_{DATA}}{2^{24}}$$

2.4.8 Handling Unused Pins in the Analog Input Circuit

If there is an unused pin in the analog input circuit, handling the unused pin according to Table 2-6 is recommended. If the unused pin is not handled accordingly, the circuit becomes susceptible to external noise and static electricity, which may deteriorate performance and cause a failure.

Table 2-6 Handling Unused Pins in the Analog Input Circuit

Pin name	Handling result	Handling method
REF0P	Connected to AVCC0 directly or via a resistor.	Connect pins 5-6 of JP8.
REF0N	Connected to AVSS0 directly or via a resistor.	Connect pins 5-6 of JP7.
AIN0 to AIN11	Connected to AVSS0 directly or via a resistor.	Use a soldering side short pad (SO1-SO13) to connect the pin to AVSS0.
LSW	Connected to AVSS0 directly or via a resistor.	

3. Microcontroller Peripheral Circuits

3.1 USB Serial Communication Circuit

Figure 3-1 shows the USB serial communication circuit on this board.

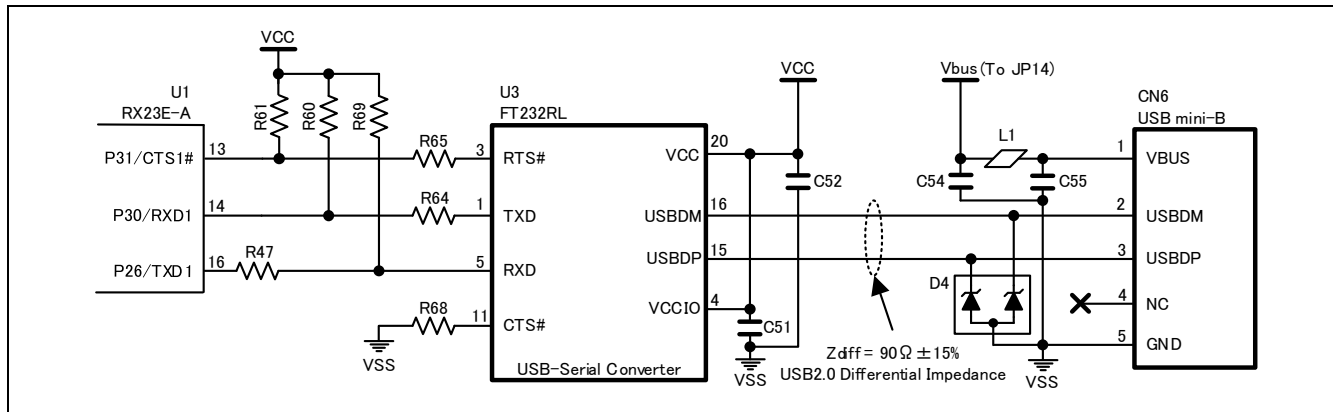

Figure 3-1 USB Serial Communication Circuit

The board has a USB serial communication conversion IC (U3: FT232RL). The FT232RL operating voltage range is 4.0 to 5.25 V. To use USB serial communication, make the following settings.

- Apply 4.0 to 5.25 V to VCC.
- Connect pins 2 and 3 of JP17.

(For details on the JP17 circuit configuration, see “3.2 Emulator Peripheral Circuit”).

3.2 Emulator Peripheral Circuit

Figure 3-2 shows the emulator peripheral circuit on the board. Table 3-1 lists the JP17 connections and corresponding functions.

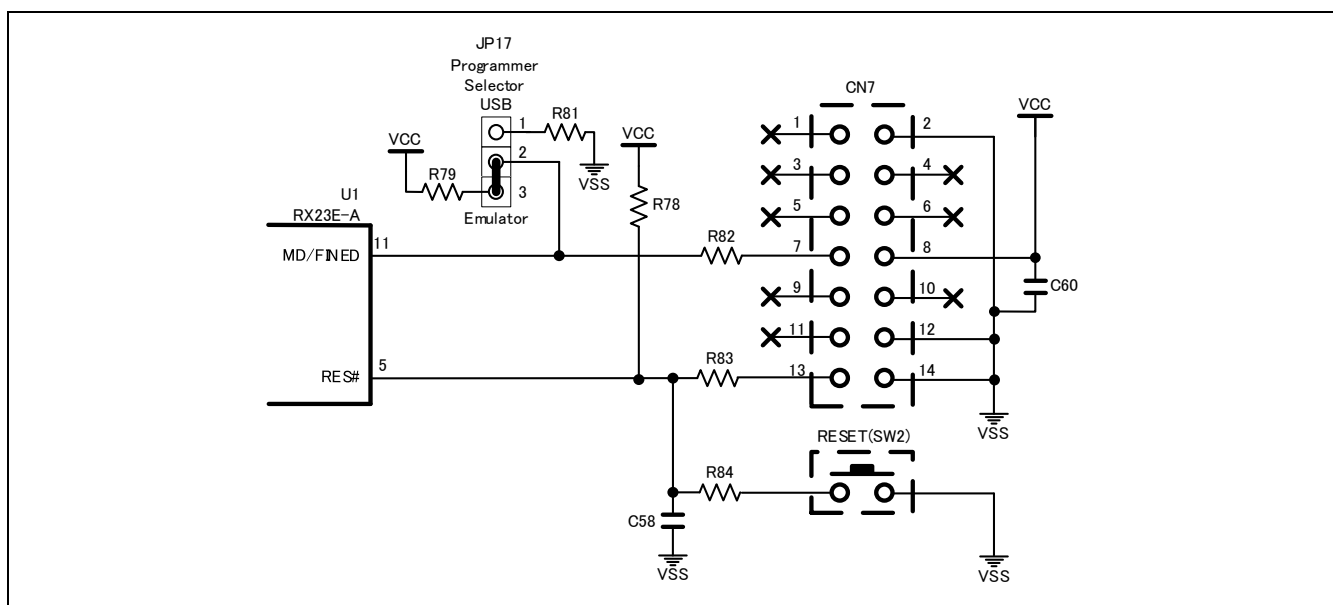

Figure 3-2 Emulator Peripheral Circuit

Table 3-1 JP17 Connections and Corresponding Functions

JP17 connection	Operating mode	Function	Remarks
Pins 1-2	Boot mode (SCI interface)	Writes the FW using the SCI interface.	Allows you to write the FW using USB serial communication (CN6).
Pins 2-3	Single-chip mode	Debugs and writes the FW using the emulator.	Applicable emulator: E1, E2, and E2 Lite

When using the emulator, connect it to CN7. **Before supplying the power from the emulator, carefully check that the power does not collide with the input power supply or LDO output.**

By pressing the RESET button (SW2) MCU RES# pin can be reset.

The MCU operating mode can be selected from the boot mode (SCI interface) or single-chip mode by changing the JP17 setting. **During power on, never change the JP17 setting. The MCU may perform unpredictable operation.**

For details on the reset operation, and boot mode operation and functions, refer to “RX23E-A Group User's Manual: Hardware”.

For details on how to use the emulator, refer to the user's manual of the emulator.

3.3 RS-485 Communication Circuit

Figure 3-3 shows the RS-485 communication circuit on the board.

The RS-485 communication circuit on the board has a PROFIBUS DP-compliant, half-duplex communication RS-485 driver ISL3159EFUZ. A 220-Ω termination resistor and a 390-Ω failsafe bias resistor are mounted on R95, R96, and R97.

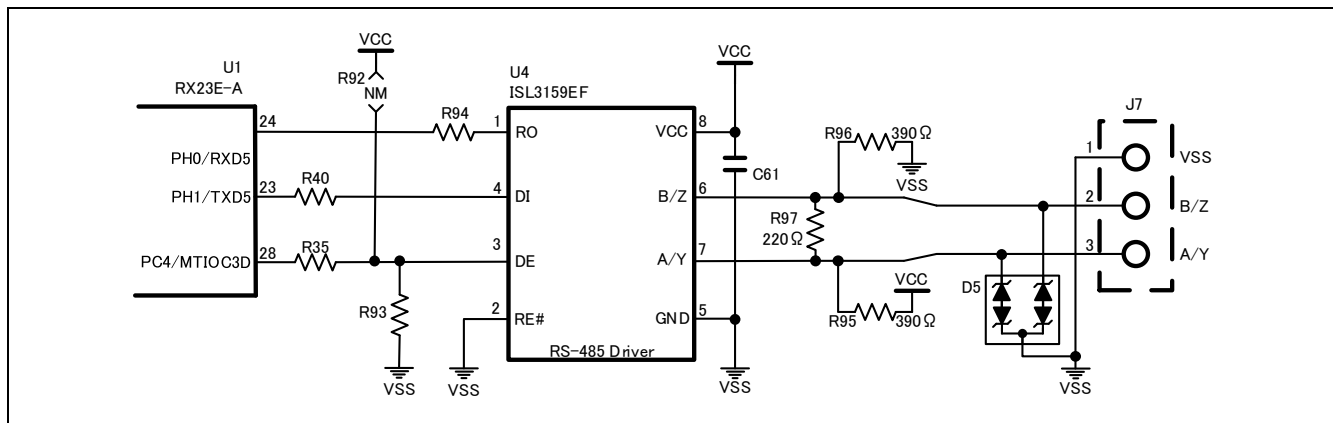

Figure 3-3 RS-485 Communication Circuit

3.4 CAN Communication Circuit

Figure 3-4 shows the CAN communication circuit on the board.

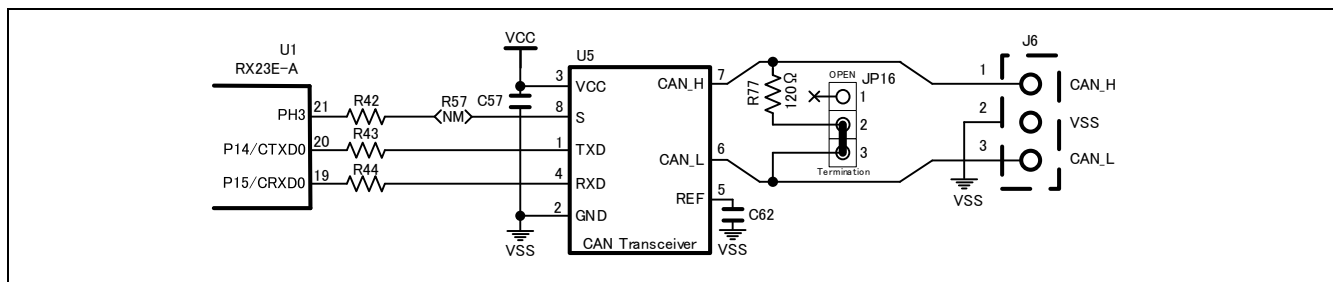

Figure 3-4 CAN Communication Circuit

The CAN communication circuit on the board has a CAN transceiver. The CAN bus can be connected directly from J6. As a termination resistor, a 120-Ω resistor is connected between CAN-H and CAN-L. When the termination resistor is required, connect pins 2 and 3 of JP16. When it is not required, connect pins 1 and 2 of JP16.

3.5 LED Circuit

Figure 3-5 shows the LED drive circuit on the board.

ON/OFF of LED1 (red) can be controlled by a port of MCU (PH2). LED2 (green) is a VCC power indicator.

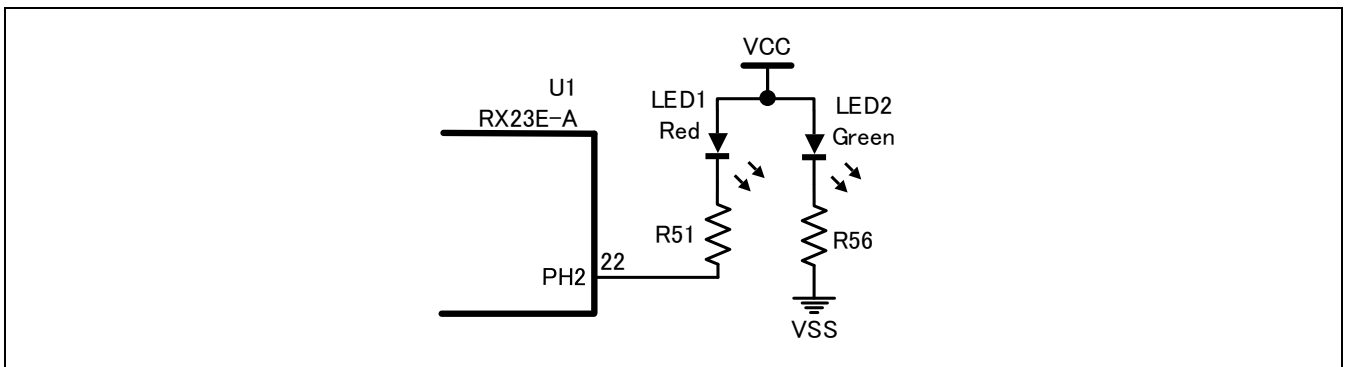

Figure 3-5 LED Drive Circuit

3.6 Switch Input Circuit

Figure 3-6 shows the switch input circuit on the board.

For details on the RESET switch (SW2), see “3.2 Emulator Peripheral Circuit”.

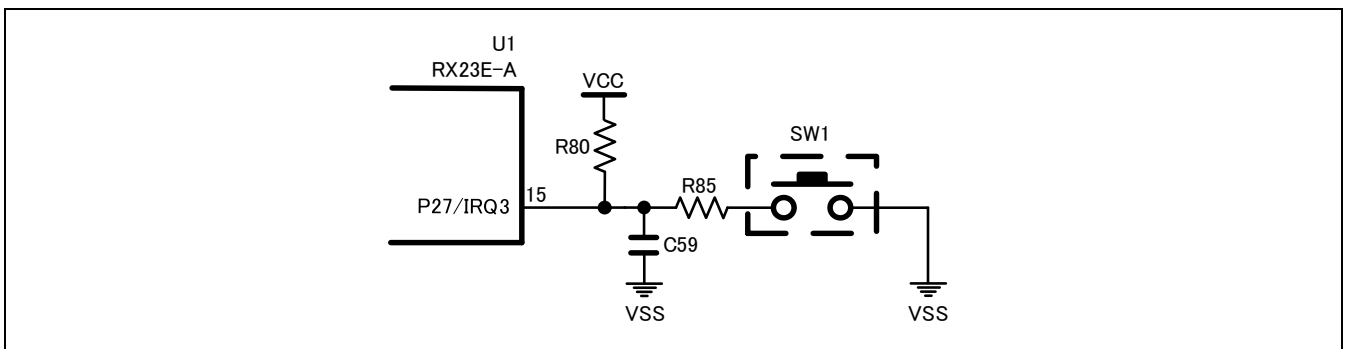

Figure 3-6 Switch Input Circuit

3.7 External Clock Input Circuit

Figure 3-7 shows the external clock input circuit on the board.

The board has an 8-MHz external crystal oscillator as an external clock input source.

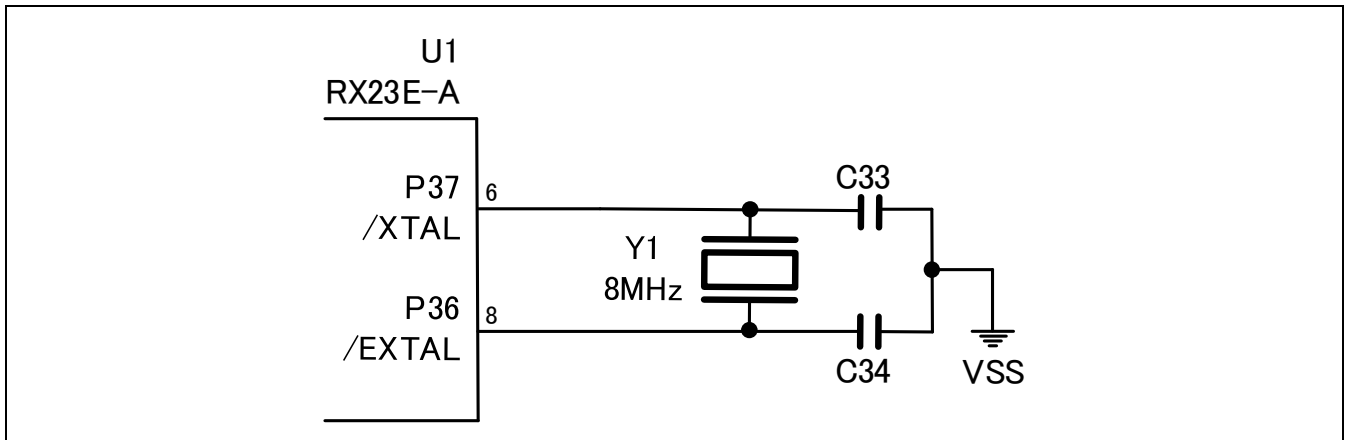

Figure 3-7 External Clock Input Circuit

4. Board Information

4.1 Using Terminal Blocks

Table 4-1 lists the part used for terminal blocks CN1, CN2, CN4, and CN5, recommended crimp terminal, crimping tool, and terminal-applicable wire diameter.

Table 4-1 Terminal Blocks and Applicable Crimp Terminal

Part model name	Applicable crimp terminal	Crimping tool	Terminal-applicable wire diameter
FFKDS/H-2,54 (Note)	AI0.25-8	CRIMPFOX CENTRUS 10S and others	AWG 24

Note FFKDSA1/H-5,08 is used as each connector termination.

If you want to use an applicable crimp terminal, you can push in the crimp terminal to connect it to a connector (push-in type). If a crimp terminal or crimping tool is unavailable, you can connect a stripped wire. To use a stripped wire, follow the procedure below.

- i) Push and hold the orange button into the board.
- ii) Insert a stripped wire into the pin insertion hole.
- iii) Release the orange button slowly.
- iv) Lightly pull the wire to confirm that it is fixed.

To remove the crimp terminal and the wire, follow the procedure below.

- i) Push and hold the orange button into the board.
- ii) Remove the crimp terminal and the wire from the pin insertion hole.
- iii) Release the orange button slowly.

4.2 Connectors

Table 4-2 lists the connectors on the board.

Table 4-2 Connectors

Reference	Connector Name	Explanation
CN1	Power Output Terminal Block	Terminal block for outputting an analog power supply. Use this connector as an excitation voltage source for a strain gage, etc.
CN2	Signal Input Terminal Block	Terminal block for inputting analog signals
CN3	Thermocouple Connector	Miniature thermocouple input socket. Copper is used for the material of both terminals. <u>The terminal screws are soldered to the board. Do NOT rotate them.</u>
CN4	System Power Input Terminal Block	Terminal block for inputting a system power supply
CN5	Analog power Input Terminal Block	Terminal block for inputting an analog power supply. Use this connector to supply an analog power supply separately from the system power supply.
CN6	USB Serial Communication Connector	Connector for USB serial communication. The connector type is USB mini-B. Use this connector for communication with PC Tool Program.
CN7	Emulator Connector	Connector for connecting an emulator. Use the 14-pin interface cable supplied with the emulator. The applicable emulator is E1, E2, and E2 Lite.

Table 4-3 to
Table 4-9 detail each connector.

Table 4-3 CN1: Power Output Terminal Block

Silk printing	Function	I/O	Explanation
+	Power supply output (AVCC0)	O	Analog power supply output for an external device. Connected to AVCC0. When using the LDO, carefully observe the current limitation.
-	GND output (AVSS0)	O	Analog GND output for an external device. Connected to AVSS0.

Table 4-4 CN2: Signal Input Terminal Block

Silk printing	Connected MCU pin	I/O	Explanation
LSW	LSW	O	LSW output pin
R0N	REF0N	I/O	Negative reference voltage input pin. Can be connected to the LSW or AVSS0 by changing the JP7 setting.
R0P	REF0P	I/O	Positive reference voltage input pin. Can be connected to AVCC0 by changing the JP8 setting.
0	AIN0	I/O	Analog signal input pin
1	AIN1	I/O	Analog signal input pin
2	AIN2	I/O	Analog signal input pin
3	AIN3	I/O	Analog signal input pin
4	AIN4/REF1N	I/O	Analog signal input pin and negative reference voltage input pin
5	AIN5/REF1P	I/O	Analog signal input pin and positive reference voltage input pin. Can be connected to RTD1 by changing the JP9 setting.
6	AIN6	I/O	Analog signal input pin. Can be connected to RTD1 by changing the JP10 setting. Can be connected to AIN8/IEXC1 by changing the JP11 setting.
7	AIN7	I/O	Analog signal input pin. Can be connected to RTD1 by changing the JP10 setting. Can be connected to AIN9/IEXC0 by changing the JP11 setting.
8	AIN8/IEXC1	I/O	Analog signal input pin and excitation current output pin. Can be connected to AIN6 by changing the JP11 setting.
9	AIN9/IEXC0	I/O	Analog signal input pin and excitation current output pin. Can be connected to AIN7 by changing the JP11 setting. Can be connected to RTD1 by changing the JP12 setting.

Note The AIN0 to AIN9 pins can be connected to excitation current sources IEXC0 to IEXC3 and used as excitation current output pins by setting MCU registers.

Table 4-5 CN3: Thermocouple Connector

Silk printing	Connected MCU pin	I/O	Explanation
AIN10	AIN10	I/O	Analog signal input pin
AIN11	AIN11	I/O	Analog signal input pin

Note The AIN10 and AIN11 pins can be connected to excitation current sources IEXC0 to IEXC3 and used as excitation current output pins by setting MCU registers.

Table 4-6 CN4: System Power Input Terminal Block

Silk printing	Function	I/O	Explanation
+	Power supply input (Vd)	I	System power supply input. Connected to Vd. Vd can be connected to VCC by changing the JP14 setting.
-	GND input (VSS)	I	GND input. Connected to VSS.

Table 4-7 CN5: Analog power Input Terminal Block

Silk printing	Function	I/O	Explanation
+	Power supply input (Va)	I	System power supply input. Connected to Va. Va can be connected to AVCC0 by changing the JP15 setting.
-	GND input (AVSS0)	I	GND input. Connected to AVSS0.

Table 4-8 CN6: USB Serial Communication Connector

Pin No.	Function	I/O	Explanation
1	Vbus	I	USB power supply pin. Connected to Vbus. Vbus can be connected to VCC by changing the JP14 setting.
2	USBDM	I/O	USB data line D-
3	USBDP	I/O	USB data line D+
4	NC (Not used)	-	-
5	GND	I	GND for an external USB power supply. Connected to VSS.

Table 4-9 CN7: Emulator Connector

Pin No.	Function	I/O	Explanation
1	(Not used)	-	-
2	VSS	O	VSS pin
3	(Not used)	-	-
4	(Not used)	-	-
5	(Not used)	-	-
6	(Not used)	-	-
7	MD/FINED	I/O	MD/FINED pin. JP7 can be used to switch between the single-chip mode (pull-up) and SCl interface boot mode (pull-down).
8	VCC	O	VCC pin
9	(Not used)	-	-
10	(Not used)	-	-
11	(Not used)	-	-
12	VSS	O	VSS pin
13	RES#	I	RES# pin
14	VSS	O	VSS pin

4.3 Pin Headers for Communication Interfaces

Table 4-10 lists the pin headers for communication interfaces on the board.

Table 4-10 Pin Headers for Communication Interfaces

Reference	Function	Explanation
J5	UART communication	Pin header for UART communication (not mounted). To use this pin header, remove R64 and R66 and mount R62 and R63. Connected to TXD1 and RXD1 of the MCU.
J6	CAN communication	Pin header for CAN communication. A CAN transceiver (U5) is mounted. A 120-Ω termination resistor is mounted between CAN_H and CAN_L. Can select whether to use of the termination resistor by using JP16
J7	RS-485 communication	Pin header for RS-485 communication. An RS-485 driver ISL3159EFUZ (U4) is mounted. A 220-Ω termination resistor and a 390-Ω failsafe bias resistor are mounted.

Table 4-11 to Table 4-13 detail each communication interface pin header.

Table 4-11 J5: Pin Header for UART Communication (Not Mounted)

Pin No.	Function	I/O	Explanation
1	VCCOUT	O	Power output pin. Connected to VCC.
2	RXIN	I	RXD input pin. To use this pin, remove R64 and mount R63. Connected to RXD1 of the MCU.
3	TXOUT	O	TXD output pin. To use this pin, remove R66 and mount R62. Connected to TXD1 of the MCU.
4	VSS	O	Signal GND connection pin. Connected to VSS.

Table 4-12 J6: Pin Header for CAN Communication

Pin No.	Function	I/O	Explanation
1	CAN_H	I/O	CAN_H pin. Connected to termination resistor R77 by changing the JP16 setting.
2	VSS	O	Signal GND connection pin. Connected to VSS.
3	CAN_L	I/O	CAN_L pin. Connected to termination resistor R77 by changing the JP16 setting.

Table 4-13 J7: Pin Header for RS-485 Communication

Pin No.	Function	I/O	Explanation
1	VSS	O	Signal GND connection pin. Connected to VSS.
2	B/Z	I/O	RS-485 driver inverting I/O pin. Connected to the B/Z pin of the driver.
3	A/Y	I/O	RS-485 driver non-inverting I/O pin. Connected to the A/Y pin of the driver.

4.4 Jumper Pins

Table 4-14 lists the jumper pins on the board.

During power on, do NOT change the setting of any jumper pin. A failure, deterioration, and/or unpredictable operation may occur.

Table 4-14 Jumper Pins

Reference	Function	Explanation
JP1 to JP6	Short-circuiting analog inputs	Used to short-circuit analog inputs.
JP7 and JP8	Selecting a reference input	Used to select REF0N or REF0P input.
JP9 to JP12	Switching the RTD measurement circuit	Switches the circuit connected to AIN5 to AIN9. Can select the circuit configuration from external input, on-board RTD measurement, four-wire RTD, or three-wire RTD measurement.
JP13	Connecting AIN5/REF1P and AIN6	Can connect AIN5/REF1P and AIN6.
JP14 and JP15	Selecting a power supply	JP14: Selects Vd, VLDO, or Vbus as VCC. JP15: Selects Va or VCC as AVCC0.
JP16	Selecting whether to use the CAN termination resistor	Can select whether to use the termination resistor between CAN_H and CAN_L.
JP17	Selecting the MCU operating mode	Can select the single-chip mode or boot mode as the MCU operating mode.

Table 4-15 to Table 4-26 detail each jumper pin.

Table 4-15 JP1 to JP6: Jumper Pins for Short-circuiting Analog Channels

Reference	Function	Explanation
JP1	Short-circuiting AIN0 and AIN1	Jumper pins for connecting AIN0 and AIN1 (not mounted)
JP2	Short-circuiting AIN2 and AIN3	Jumper pins for connecting AIN2 and AIN3
JP3	Short-circuiting AIN4 and AIN5	Jumper pins for connecting AIN4 and AIN5 (not mounted)
JP4	Short-circuiting AIN6 and AIN7	Jumper pins for connecting AIN6 and AIN7 (not mounted)
JP5	Short-circuiting AIN8 and AIN9	Jumper pins for connecting AIN8 and AIN9
JP6	Short-circuiting AIN10 and AIN11	Jumper pins for connecting AIN10 and AIN11 (not mounted)

Table 4-16 JP7: Jumper Pins for Selecting REF0N Input

JP7 connection	Signal name	Explanation
Pins 1-2	-	Select this setting to input an external reference from CN2 to REF0N.
Pins 3-4	REF0N-LSW	Connects LSW to REF0N.
Pins 5-6	REF0N-AVSS0	Connects AVSS0 to REF0N.

Table 4-17 JP8: Jumper Pins for Selecting REF0P Input

JP8 connection	Signal name	Explanation
Pins 1-2	-	Select this setting to input an external reference from CN2 to REF0P.
Pins 3-4	-	Not used.
Pins 5-6	AVCC0-REF0P	Connects AVCC0 to REF0P.

Table 4-18 JP9: Jumper Pins for Connecting AIN5/REF1P to the On-Board RTD

JP9 connection	Signal name	Explanation
Pins 1-2	-	Select this setting to input signals from CN2 to AIN5/REF1P.
Pins 2-3	RTD1-REF1P	Connects RTD1 to REF1P. Select this setting to use the on-board RTD.

Table 4-19 JP10: Jumper Pins for Connecting AIN6 and AIN7 to the On-Board RTD

JP10 connection	Signal name	Explanation
Pins 1-2 and Pins 3-4	-	Select this setting to input signals from CN2 to AIN6 and AIN7.
Pins 5-6 and Pins 7-8	RTD1-AIN6 AIN7-RTD1	Connects AIN6 and AIN7 to both ends of RTD1. Select this setting to use the on-board RTD.

Table 4-20 JP11: Jumper Pins for Connecting AIN8 and AIN9 to the Three-Wire RTD

JP11 connection	Signal name	Explanation
Pins 1-2 and Pins 3-4	-	Select this setting to input signals from CN2 to AIN6, AIN7, AIN8, and AIN9.
Pins 5-6 and Pins 3-4	AIN9-AIN7 AIN8-AIN6	Connects AIN6 and AIN8, and AIN7 and AIN9. Select this setting to connect the three-wire RTD to CN2.

Table 4-21 JP12: Jumper Pins for Connecting AIN9 to the On-Board RTD

JP12 connection	Signal name	Explanation
Pins 1-2	-	Select this setting to input signals from CN2 to AIN9.
Pins 3-4	RTD1-AIN9	Connects RTD1 to AIN9. Select this setting to use the on-board RTD.

Table 4-22 JP13: Jumper Pins for Connecting AIN5/REF1P and AIN6

JP13 connection	Signal name	Explanation
Pins 1-2	AIN5/REF1P-AIN6	Connects AIN5/REF1P and AIN6 (not mounted).

Table 4-23 JP14: Jumper Pins for Selecting a System Power Supply

JP14 connection	Signal name	Explanation
Pins 1-2	VCC-Vd	Connects Vd to VCC. Select this setting to operate the board with the power supplied from CN4.
Pins 3-4	VCC-VLDO	Connects VLDO to VCC. Select this setting to operate the board with the LDO output.
Pins 5-6	VCC-Vbus	Connects Vbus to VCC. Select this setting to operate the board with the USB power supply.

Table 4-24 JP15: Jumper Pins for Selecting an Analog Power Supply

JP15 connection	Signal name	Explanation
Pins 1-2	Va-AVCC0	Connects Va to AVCC0. Select this setting to operate the analog side of the MCU with the power supplied from CN5. When using this setting, supply power to VCC in advance.
Pins 2-3	AVCC0-VCC	Connects VCC to AVCC0. Select this setting to use the common power supply for AVCC0 and VCC.

Table 4-25 JP16: Jumper Pins for Selecting Whether to Use the CAN Bus Termination Resistor

JP16 connection	Signal name	Explanation
Pins 1-2	-	Disables the termination resistor.
Pins 2-3	-	Enables the termination resistor.

Table 4-26 JP17: Jumper Pins for Selecting the MCU Operating Mode

JP17 connection	Function	Explanation
Pins 1-2	MD/FINED pull-down	Sets the MCU operating mode to the boot mode (SCI interface). In the boot mode, the FW written at shipment does not operate. You can write the FW with USB serial communication (CN6).
Pins 2-3	MD/FINED pull-up	Sets the MCU operating mode to the single-chip mode. Use this setting to operate the FW written at shipment. You can debug and write the FW using the emulator (CN7).

4.5 Universal Through-Holes

Table 4-27 lists the universal through-holes on the board.

All pins in the digital side of the MCU are connected to universal through-holes. The function of a pin connected to a universal through-hole can be changed with a user program. For the initial setting of each pin, see “4.9 Initial Settings of MCU Pins”.

For details of available functions and how to change the function, refer to “RX23E-A User's Manual: Hardware”.

Table 4-27 Universal Through-Holes

Reference	Function	Explanation
J1	Power through-holes	Power input through-holes. Can be connected to Vd and VSS.
J2	PWM output through-holes	PWM output through-holes. Can be connected to MTIOC3x of the MCU.
J3	Communication interface through-holes	Communication interface connection through-holes. Can be connected to the SCI5 interface, CAN module, SPI interface, and others.
J4	SCI1 interface through-holes	SCI1 interface connection through-holes

Table 4-28 to Table 4-31 detail each universal through-hole. **If inputting voltage to pin whose MCU pin number is described in the table, set the pin to input and keep in range described in the table “Table 2-1 Recommended Operating Conditions”.** Failure to observe the conditions may cause failure or damage to the MCU.

Table 4-28 J1: Power Through-Holes

Pin No.	Function	I/O	Explanation
1	VSS	I	VSS pins
2	VSS	I	
3	Vd	I	Vd pins
4	Vd	I	

Table 4-29 J2: PWM Output Through-Holes

Pin No.	MCU Pin No.	Function	I/O	Explanation
1	—	VSS	O	VSS pin
2	—	VCC	O	VCC pin. Used for supplying power to an external device.
3	—	VSS	O	VSS pin
4	—	VCC	O	VCC pin. Used for supplying power to an external device.
5	31	PB0	I/O	PB0 pin. Pulled up to VCC with R26.
6	29	PB1	I/O	PB1 pin. Pulled up to VCC with R27.
7	—	VSS	O	VSS pin
8	—	VSS	O	VSS pin
9	28	PC4/MTIOC3D	I/O	PC4/MTIOC3D/RTS5# pin. Connected to U4. To use the through-hole, remove R89.
10	27	PC5/MTIOC3B	I/O	PC5/MTIOC3B pin
11	26	PC6/MTIOC3C	I/O	PC6/MTIOC3C pin
12	25	PC7/MTIOC3A	I/O	PC7/MTIOC3A pin

Table 4-30 J3: Communication Interface Through-Holes

Pin No.	MCU Pin No.	Function	I/O	Explanation
1	—	VSS	O	VSS pin
2	—	VCC	O	VCC pin. Used for supplying power to an external device.
3	23	PH1/TXD5	I/O	PH1/TXD5 pin. Connected to U4. To use the through-hole, remove R90.
4	24	PH0/RXD5	I/O	PH0/RXD5 pin. Connected to U4. To use the through-hole, remove R91.
5	21	PH3/CANMODE	I/O	PH3/CANMODE pin. Pulled up to VCC with R28.
6	22	PH2	I/O	PH2 pin. Connected to LED1. To use the through-hole, remove R51.
7	19	P15/SMISO1/CRXD0	I/O	P15/SMISO1/CRXD0 pin. Connected to U5. To use the through-hole, remove R59.
8	20	P14/SS1#/CTXD0	I/O	P14/SS1#/CTXD0 pin. Connected to U5. To use the through-hole, remove R58.
9	17	P17/SCK1/SDA	I/O	P17/SCK1/SDA pin
10	28	P16/SMOSI1/SCL	I/O	P16/SMOSI1/SCL pin

Table 4-31 J4: SCI1 Interface Through-Holes

Pin No.	MCU Pin No.	Function	I/O	Explanation
1	15	P27/IRQ3/SW1	I/O	P27/IRQ3/SW1 pin. Connected to SW1 via R85. Pulled up to VCC with R80.
2	16	P26/TXD1	I/O	P26/TXD1 pin. Pulled up to VCC with R69. To use the through-hole, remove R66. When R66 is removed, the pull-up with R69 is disabled.
3	—	VSS	O	VSS pin
4	14	P30/RXD1	I/O	P30/RXD1 pin. Pulled up to VCC with R60. To use the through-hole, remove R64.
5	12	P35/NMI	I	P35/NMI pin. Pulled up to VCC with R29.
6	13	P31/CTS1#	I/O	P31/CTS1# pin. Pulled up to VCC with R61. To use the through-hole, remove R65.
7	8	P36/EXTAL	I/O	P36 pin. Unconnected at shipment. To use the through-hole, remove R22 and R23 and mount R21. When R22 or R23 is removed, the external crystal oscillator (Y1) cannot be used.
8	11	MD/FINED	I/O	MD/FINED pin. The pull-up or pull-down can be selected with JP17.
9	6	P37/XTAL	I/O	P37 pin. Unconnected at shipment. To use the through-hole, remove R22 and R23 and mount R24. When R22 or R23 is removed, the external crystal oscillator (Y1) cannot be used.
10	5	RES#	I	RES# pin. Pulled up with R78. Connected to SW2 via R84.

4.6 Through-Hole Taps

Table 4-32 lists the through-hole taps on the board.

Table 4-32 Through-Hole Taps

Reference	Signal name	Explanation
TH1	AVSS0	Shielded wire can be connected to AVSS0 with an M3 screw.
TH2 to TH5	VSS	Pads for mounting TH-1.6-x-M2 (Mac-Eight)

4.7 Test Points

Table 4-33 lists the test points on the board.

TP1 and TP4 have a check pin.

Table 4-33 Test Points

Reference	Signal name	Explanation
TP1	AVSS0	Connected to AVSS0.
TP2	AVCC0	Connected to AVCC0.
TP3	REFOUT	Connected to REFOUT.
TP4	VSS	Connected to VSS.
TP5	VCC	Connected to VCC.
TP6	Vd	Connected to Vd.
TP7	VLDO	Connected to VLDO.
TP8	Va	Connected to Va.
TP9	Vbus	Connected to Vbus.

4.8 Short Pads

Table 4-34 lists the short pads on the board.

SO1 to SO13 are factory-set to the unconnected state. You can handle these unused pins simply by short-circuiting them with soldering.

SS1 is factory-set to the connected state. You can disconnect the connection by cutting the pattern.

Table 4-34 Short Pads

Reference	Signal name	Initial state	Explanation
SO1	LSW	Unconnected	Can connect LSW to AVSS0.
SO2	AIN0	Unconnected	Can connect AIN0 to AVSS0.
SO3	AIN1	Unconnected	Can connect AIN1 to AVSS0.
SO4	AIN2	Unconnected	Can connect AIN2 to AVSS0.
SO5	AIN3	Unconnected	Can connect AIN3 to AVSS0.
SO6	AIN4	Unconnected	Can connect AIN4 to AVSS0.
SO7	AIN5	Unconnected	Can connect AIN5 to AVSS0.
SO8	AIN6	Unconnected	Can connect AIN6 to AVSS0.
SO9	AIN7	Unconnected	Can connect AIN7 to AVSS0.
SO10	AIN8	Unconnected	Can connect AIN8 to AVSS0.
SO11	AIN9	Unconnected	Can connect AIN9 to AVSS0.
SO12	AIN10	Unconnected	Can connect AIN10 to AVSS0.
SO13	AIN11	Unconnected	Can connect AIN11 to AVSS0.
SS1	VSS- AVSS0	Connected	Connects VSS and AVSS0.

4.9 Initial Settings of MCU Pins

Table 4-35 and Table 4-36 list the initial settings of MCU pins.

The AIN6 to AIN11 pins can be used as AN000 to AN005 which are pins for a 12-bit successive approximation A/D converter (S12ADE) and VREFH0 and VREFL0 which are reference voltage input pins. For details, refer to “RX23E-A User’s Manual: Hardware”.

Table 4-35 Initial Settings of MCU Pins (1/2)

MCU pin No.	MCU pin name in the circuit diagram	Pin function	I/O setting	Connected destination on the board
1	AIN10	AIN10	-	CN3
2	AIN11	AIN11	-	CN3
3	AVSS0-1	AVSS0	-	AVSS0
4	AVCC0-1	AVCC0	-	AVCC0
5	RES#	RES#	-	J4 and SW2
6	P37/XTAL	XTAL	-	Y1
7	VSS-1	VSS	-	VSS
8	P36/EXTAL	EXTAL	-	Y1
9	VCC-1	VCC	-	VCC
10	VCL	VCL	-	VCC
11	MD/FINED	MD/FINED	-	CN7
12	P35	NMI	Input	J4, pull-up (VCC)
13	P31/CTS1#	CTS#1	-	J4 and U3, pull-up (VCC)
14	P30/RXD1	RXD1	-	J4 and U3, pull-up (VCC)
15	P27/IRQ3	P27	Input	J4 and SW1, pull-up (VCC)
16	P26/TXD1	TXD1	-	J4 and U3
17	P17/SCK1/SDA	P17	Input	J3
18	P16/SMOSI1/SCL	P16	Input	J3
19	P15/SMISO1/CRXD0	P15	Input	J3 and U5
20	P14/SS1#/CTXD0	P14	Input	J3 and U5
21	PH3	PH3	Input	J3, pull-up (VCC)
22	PH2	PH2	Output	J3, LED1
23	PH1/TXD5	PH1	Input	J3 and U4
24	PH0/RXD5	PH0	Input	J3 and U4
25	PC7/MTIOC3A	PC7	Input	J2
26	PC6/MTIOC3C	PC6	Input	J2
27	PC5/MTIOC3B	PC5	Input	J2
28	PC4/MTIOC3D	PC4	Input	J2 and U4, pull-down (VSS)

Table 4-36 Initial Settings of MCU Pins (2/2)

MCU pin No.	MCU pin name in the circuit diagram	Pin function	I/O setting	Connected destination on the board
29	PB1	PB1	Input	J2, pull-up (VCC)
30	VCC-2	VCC	-	VCC
31	PB0	PB0	Input	J2, pull-up (VCC)
32	VSS-2	VSS	-	VSS
33	AVCC0-2	AVCC0	-	AVCC0
34	AVSS0-2	AVSS0	-	AVSS0
35	REFOUT	REFOUT	-	REFOUT
36	LSW	LSW (Note)	-	CN2
37	REF0N	REF0N	-	CN2
38	REF0P	REF0P	-	CN2
39	AIN0	AIN0	-	CN2
40	AIN1	AIN1	-	CN2
41	AIN2	AIN2	-	CN2
42	AIN3	AIN3	-	CN2
43	AIN4/REF1N	AIN4	-	CN2
44	AIN5/REF1P	AIN5	-	CN2
45	AIN6	AIN6	-	CN2
46	AIN7	AIN7	-	CN2
47	AIN8/IEXC1	AIN8	-	CN2
48	AIN9/IEXC0	AIN9	-	CN2

Note LSW is set to the switch OFF state in the FW at shipment.

Appendix

Appendix 1. Board Diagrams

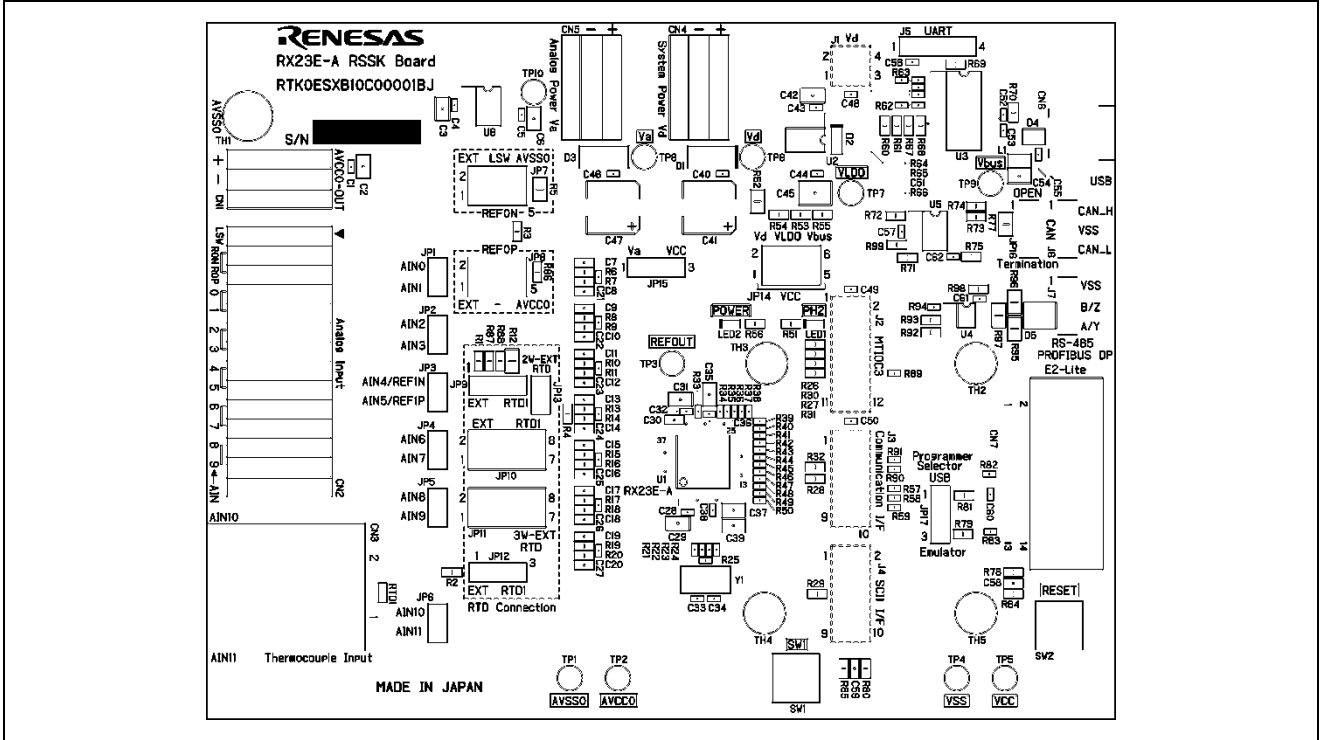

Silkscreen on the Component (Top) Side

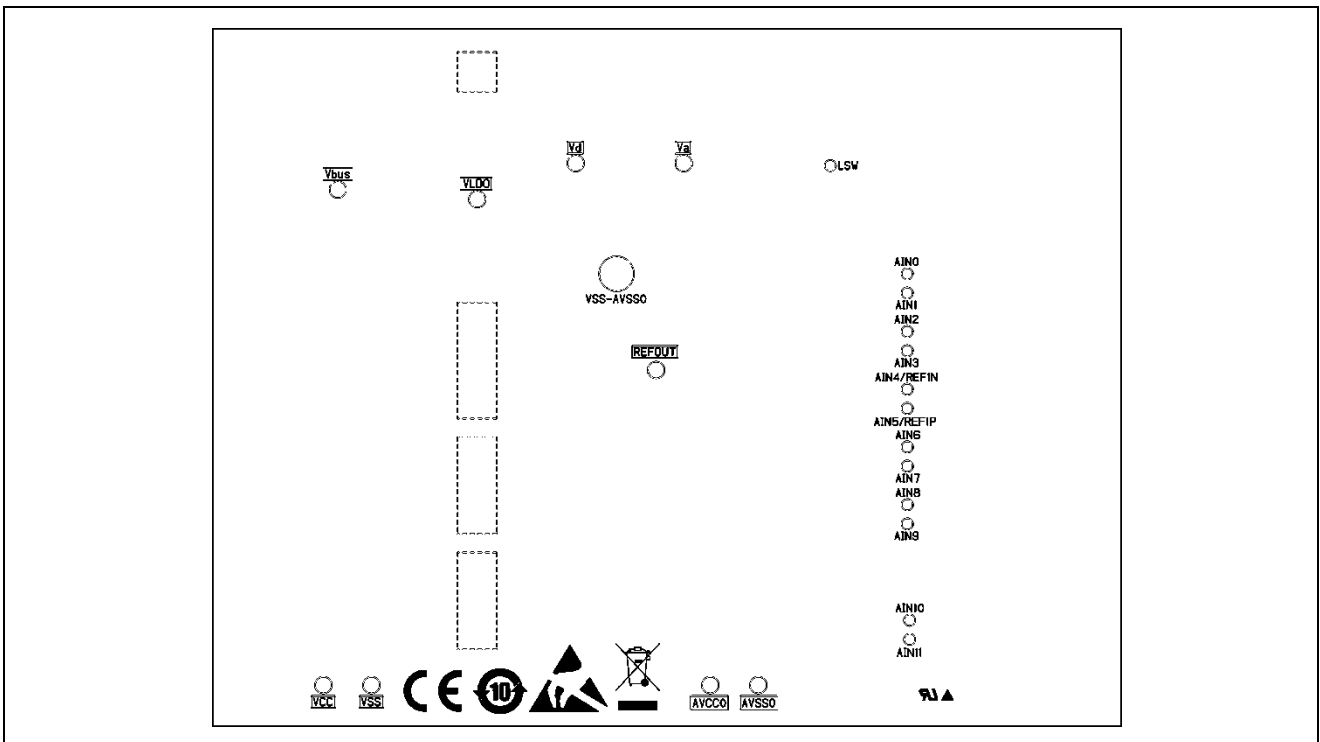

Silkscreen on the Soldering (Bottom) Side (Viewed from the Soldering Side)

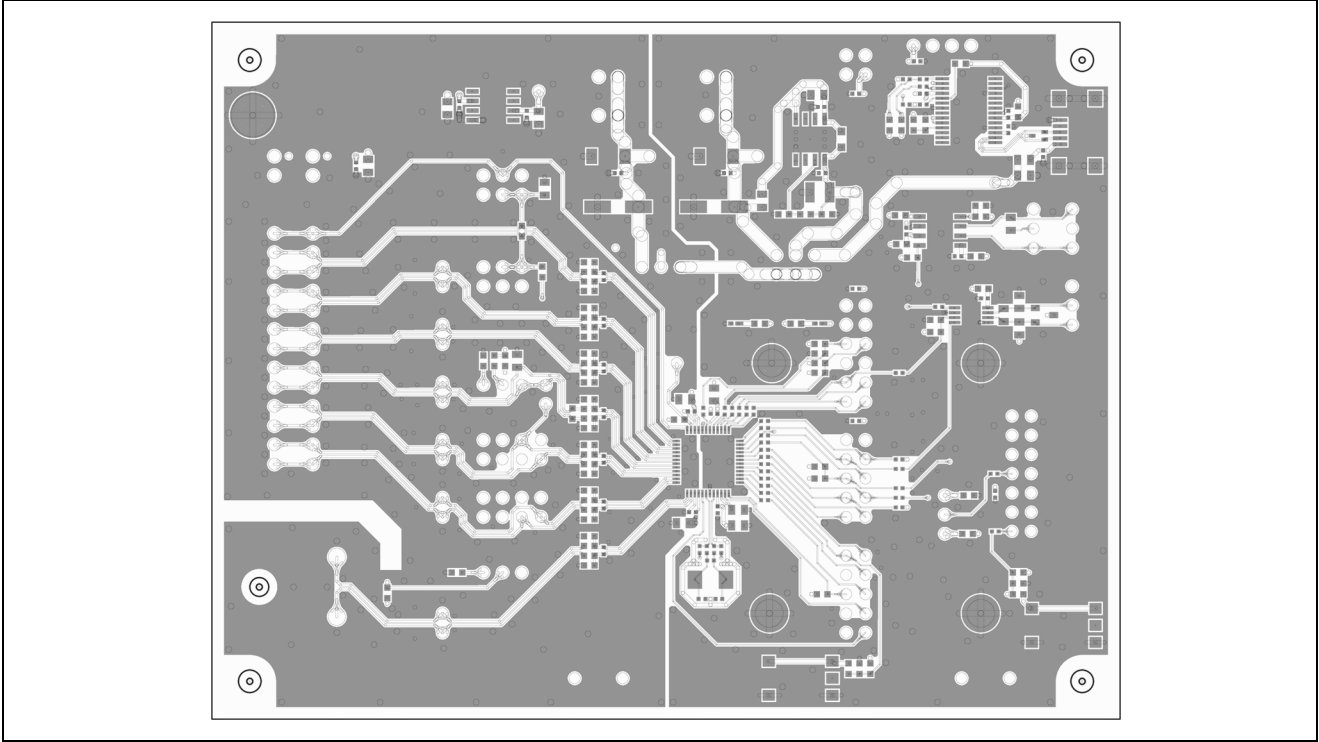

Layer 1: Top Side Layer

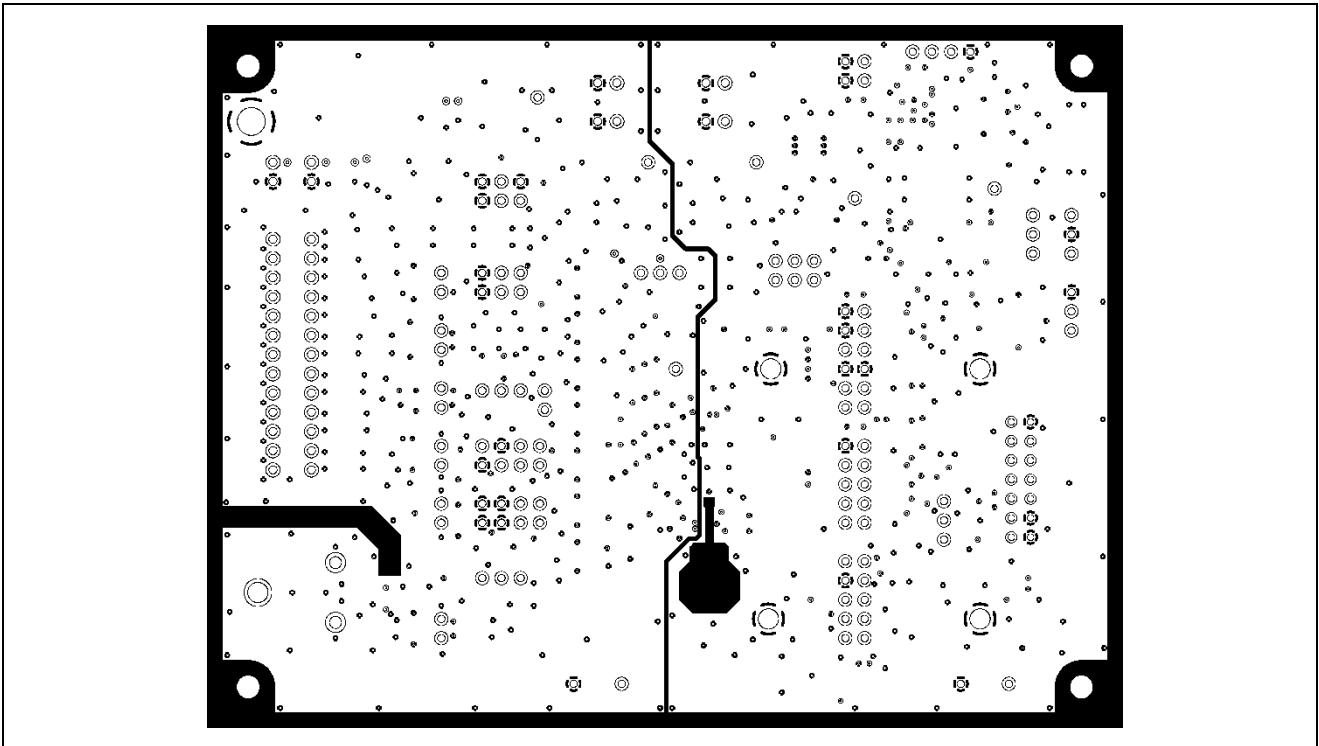

Layer 2: Ground Plane

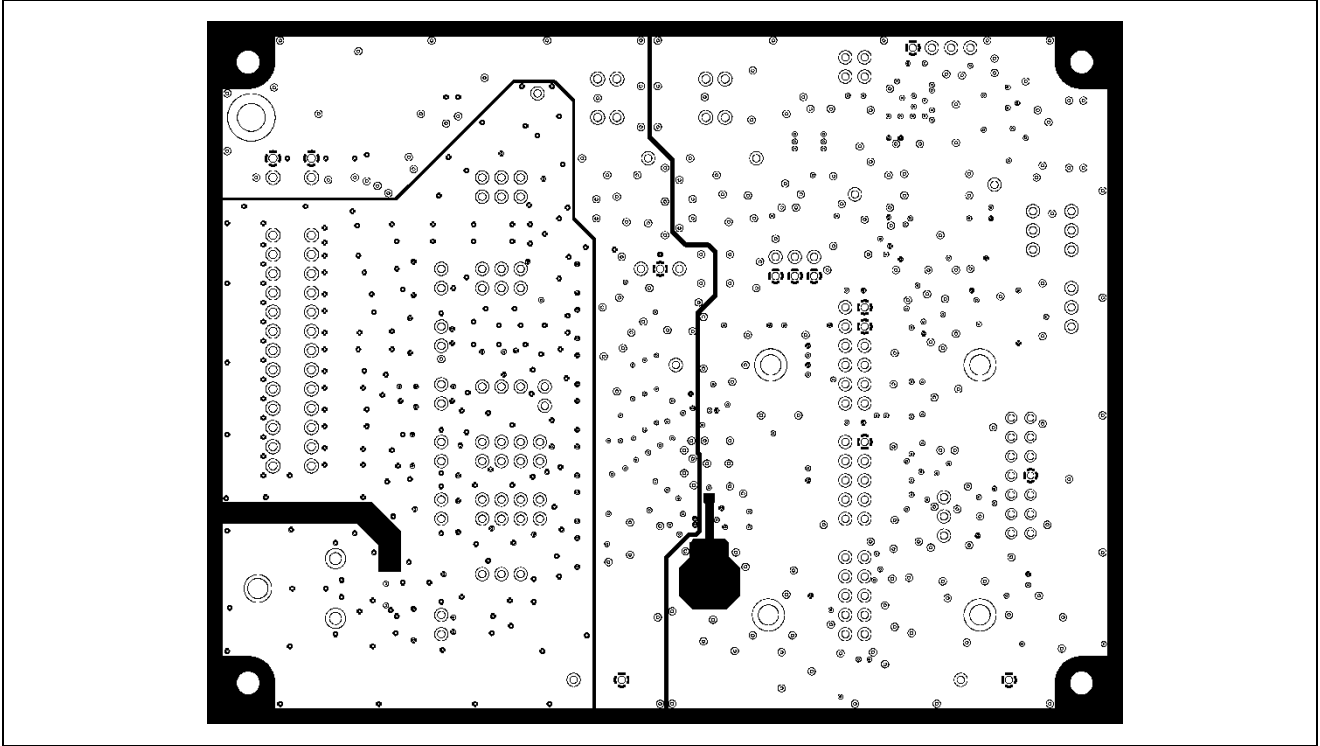

Layer 3: Power and Ground Plane

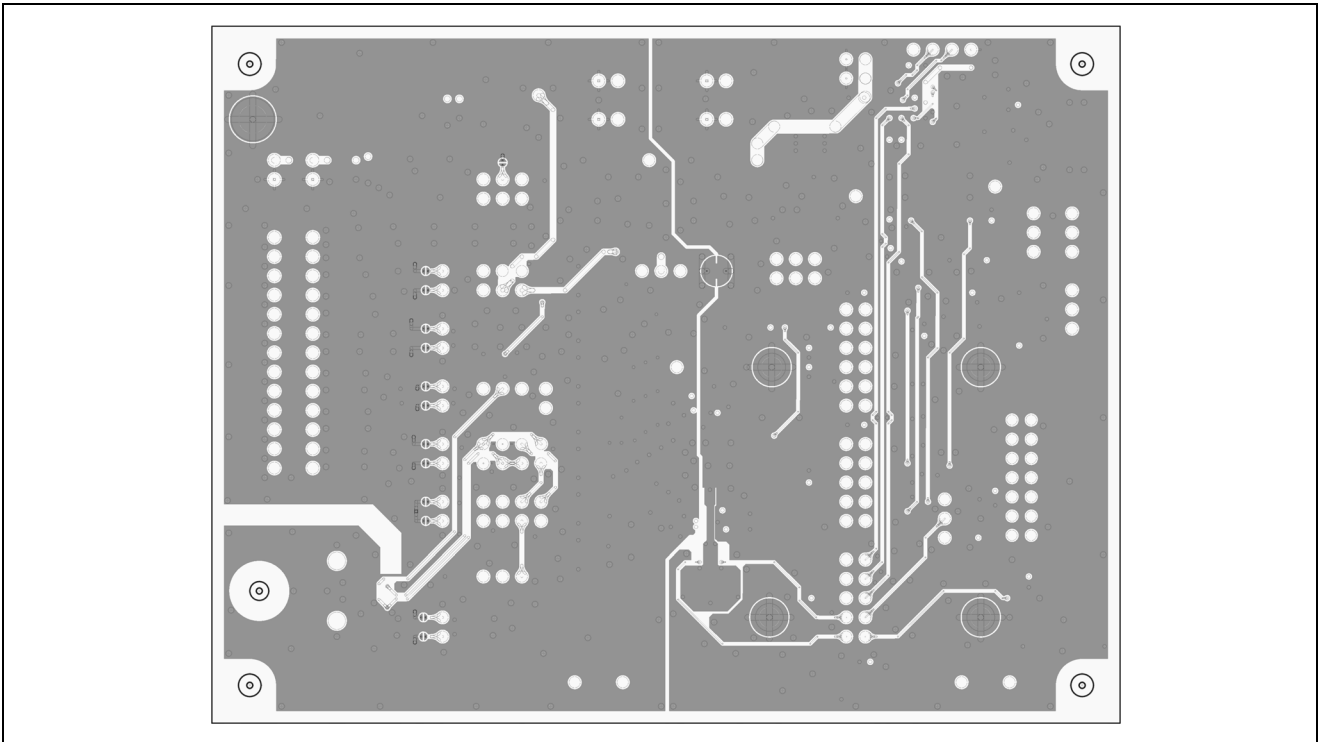

Layer 4: Bottom Side Layer (Viewed from the Component Side)

Appendix 2. Circuit Diagram

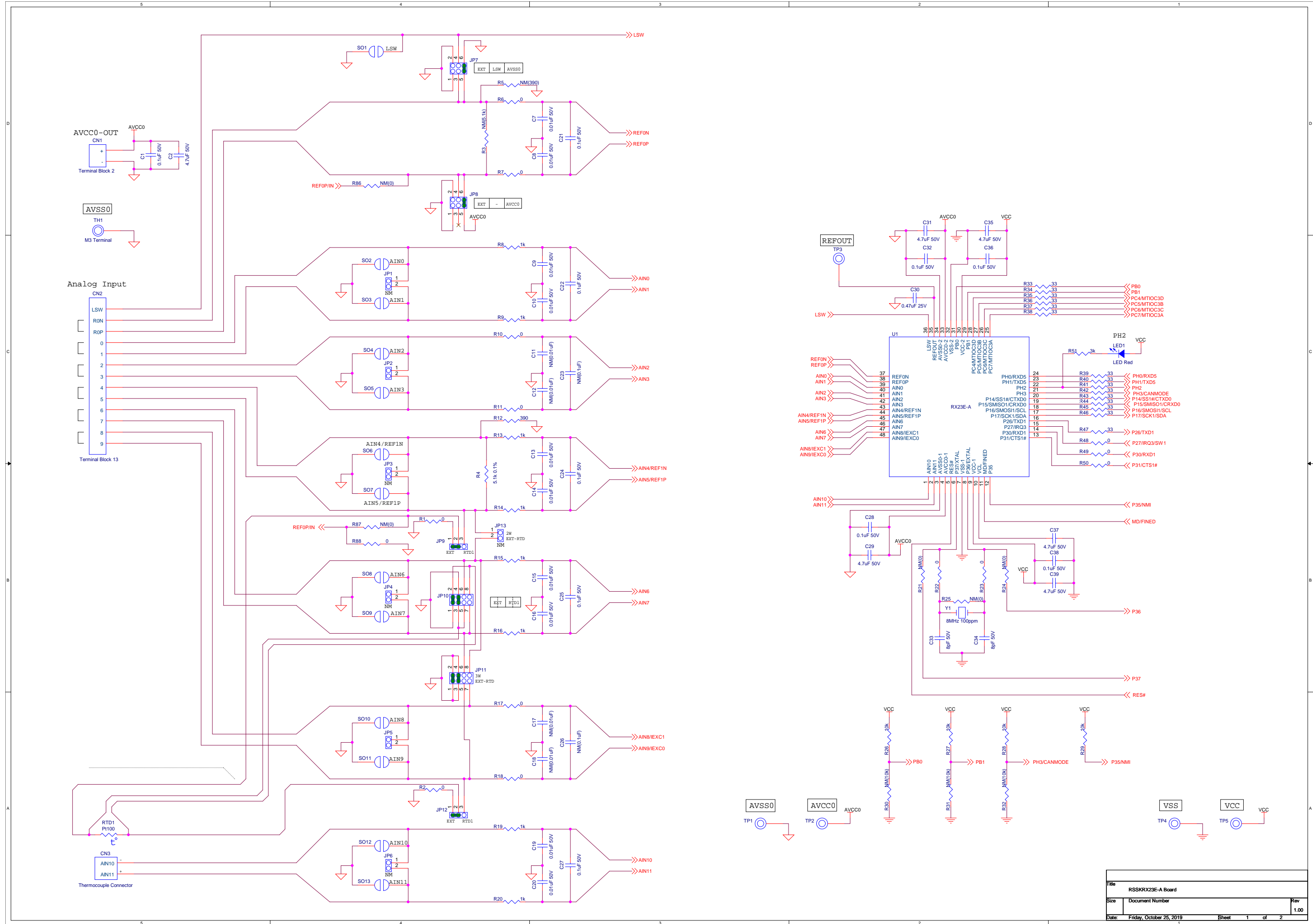

Power Input

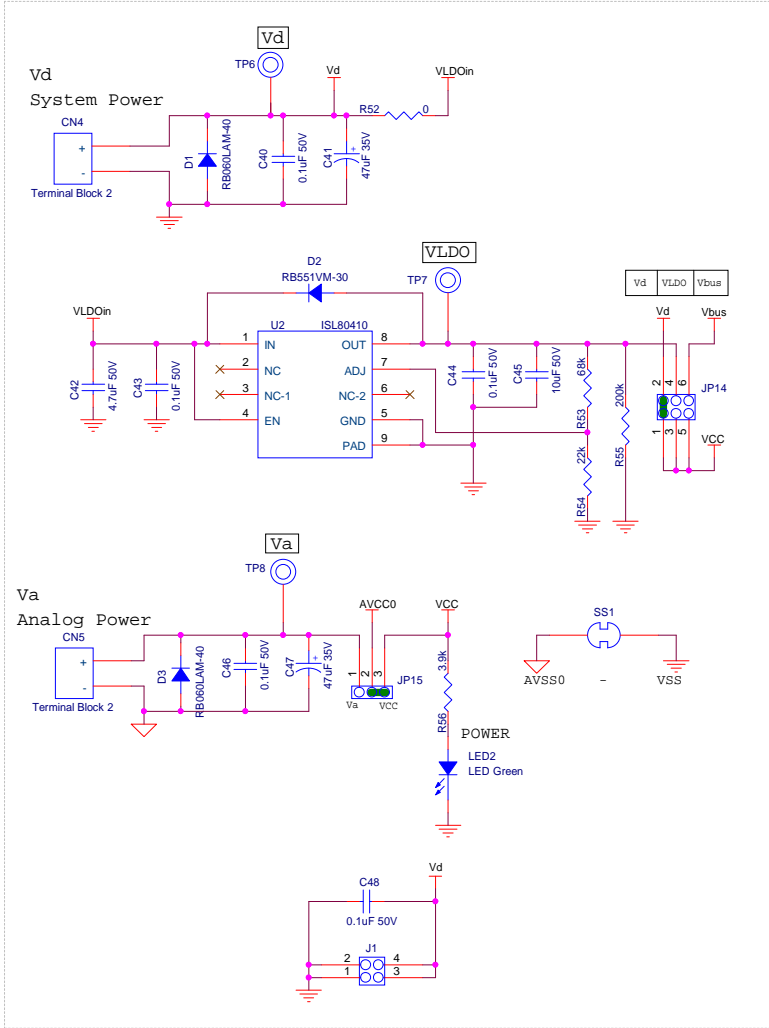

Digital Output

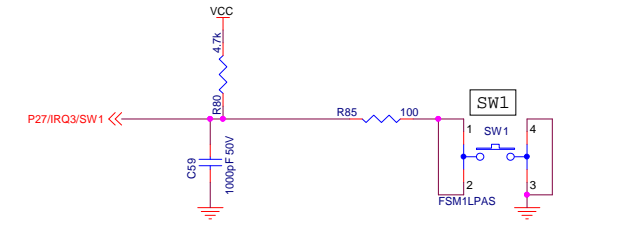
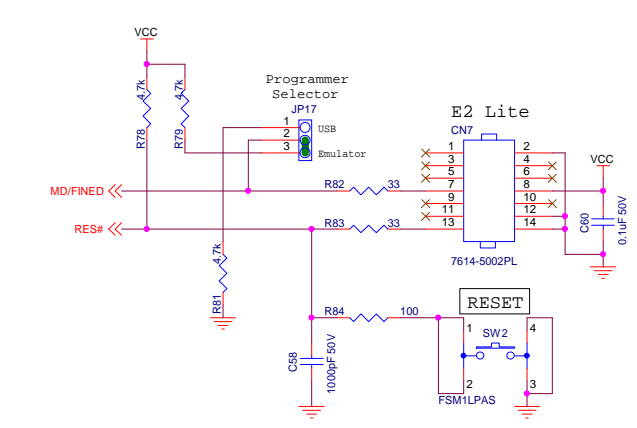
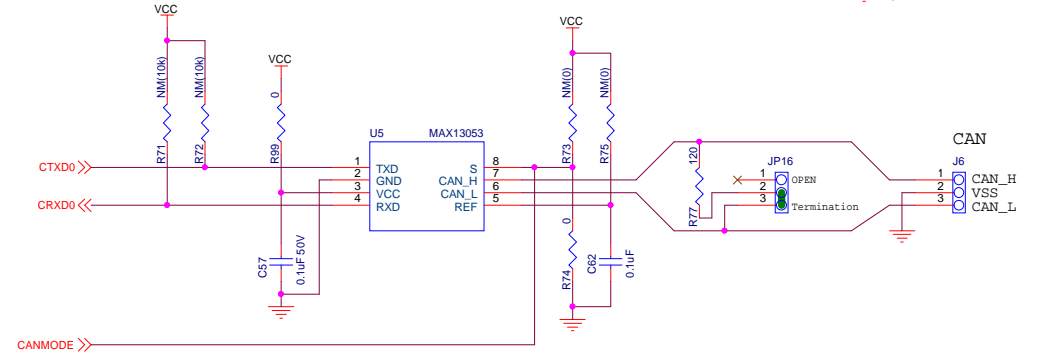
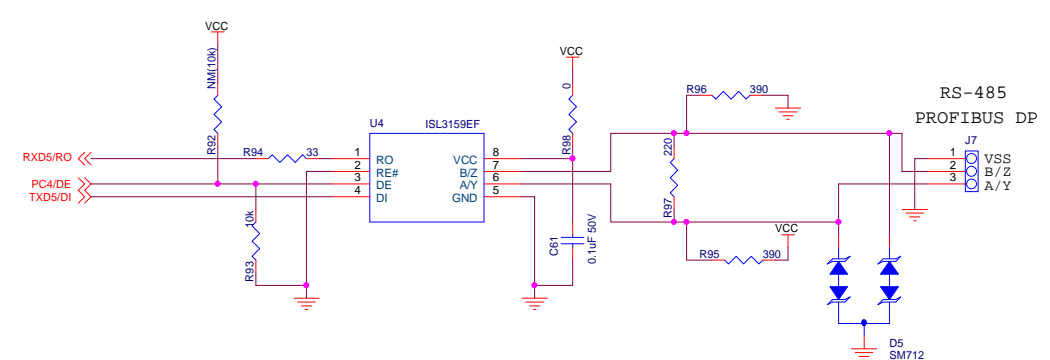
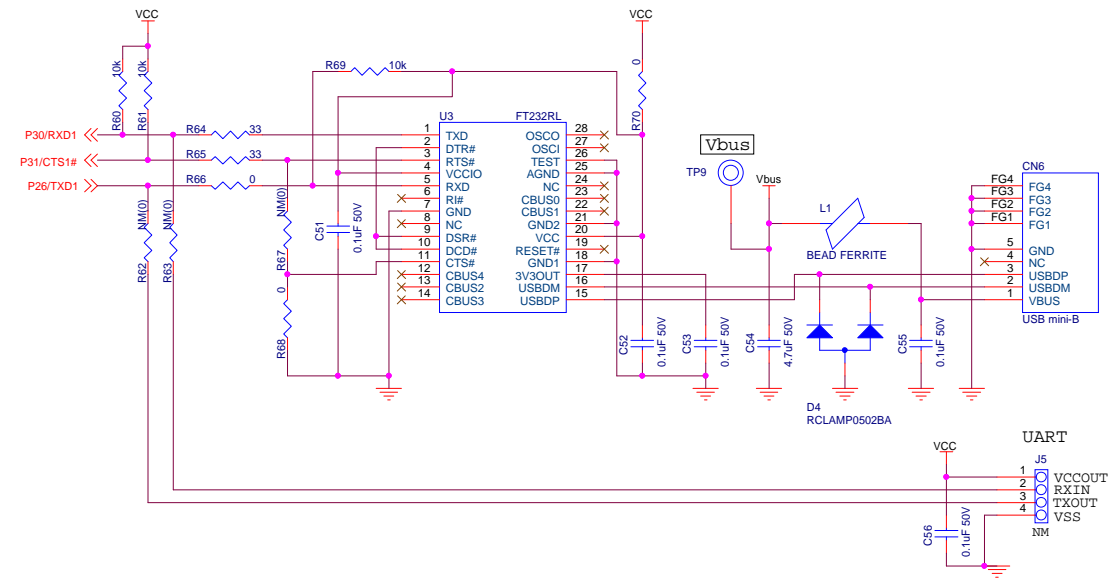
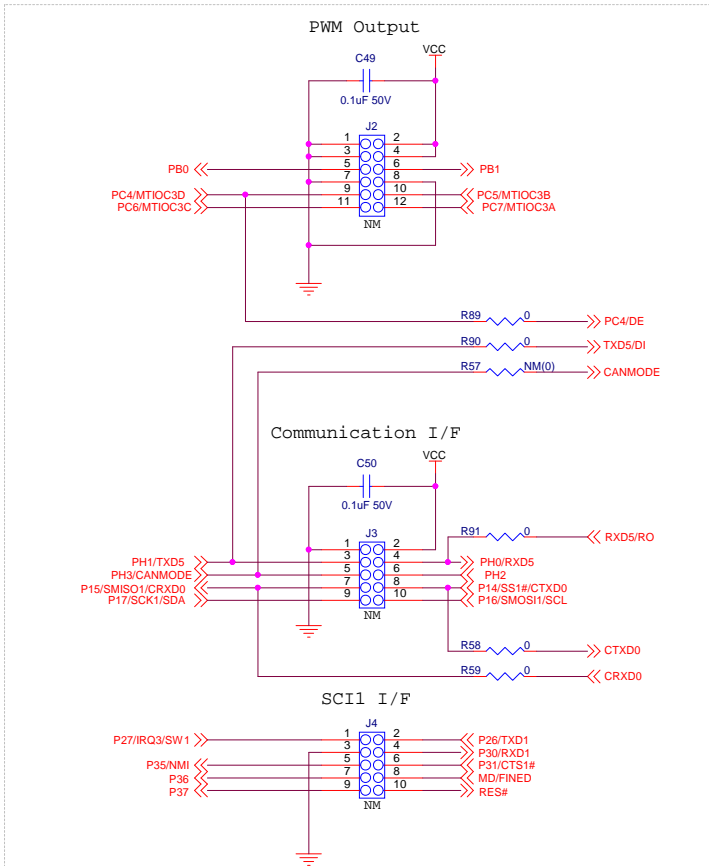

File	RSSKRX23E-A Board	
Size	Document Number	Rev
Date	Friday, October 25, 2019	Sheet 2 of 2
		1.00

Appendix 3. Parts list

No.	Quantity (Mounted)	Reference Designator (Mounted)	Reference Designator (Not Mounted)	Description	Part Name	Manufacturer Part Name※	Maker Name
1	3	CN1,CN4,CN5		Terminal block	Connector	FFKDSA1/H-2,54-2	Phoenix contact
2	1	CN2		Terminal block	Connector	FFKDSA1/H-2,54-13	Phoenix contact
3	1	CN3		Thermocouple connector	Connector	FMTC-CU-PCB	LABFACILITY
4	1	CN6		USB-miniB	Connector	UB-M5BR-G14-4S	JST
5	1	CN7		14-pin connector	Connector	7614-5002PL	3M
6	26	C1,C21,C22,C24,C25,C27,C28,C32,C36,C38,C40,C43,C44,C46,C48,C49,C50,C51,C52,C53,C55,C56,C57,C60,C61,C62	C23,C26	0.1uF, 50V	Ceramic capacitor	CGA2B3X7R1H104K050BB	TDK
7	8	C2,C29,C31,C35,C37,C39,C42,C54		4.7uF, 50V	Ceramic capacitor	GRM21BC71H475KE11	murata
8	10	C7,C8,C9,C10,C13,C14,C15,C16,C19,C20	C11,C12,C17,C18	0.01uF, 50V	Ceramic capacitor	GRM1885C1H103JA01	murata
9	1	C30		0.47uF, 25V	Ceramic capacitor	TMK107B7474KA	Taiyo Yuden
10	2	C33,C34		8pF, 50V	Ceramic capacitor	GCM1555C1H8R0DA16	murata
11	2	C41,C47		47uF, 35V	Electrolytic capacitor	EEE-HDV470XAP	Panasonic
12	1	C45		10uF, 50V	Ceramic capacitor	CGA6P3X7S1H106M250AE	TDK
13	2	C58,C59		1000pF, 50V	Ceramic capacitor	CGA3E2X7R1H102K080AA	TDK
14	2	D1,D3		Schottky barrier	Diode	RB060LAM-40	Rohm
15	1	D2		Schottky barrier	Diode	RB551VM-30	Rohm
16	1	D4		ESD & CDE protection	Diode	RCLAMP0502BA	Semtech
17	1	D5		SM712	Diode	SM712.TCT	Semtech
18	2	JP2,JP5	JP1,JP3,JP4,JP6,JP13	HEADER 2	Pin header	M20-9990245	Harwin
19	3	JP7,JP8,JP14		HEADER 3X2	Pin header	M20-9980345	Harwin
20	7	J6,J7,JP9,JP12,JP15,JP16,JP17		HEADER 3	Pin header	M20-9990345	Harwin
21	2	JP10,JP11		HEADER 4X2	Pin header	M20-9980445	Harwin
22	0		J1	HEADER 2X2	Pin header	M20-9980245	Harwin
23	0		J2	HEADER 6X2	Pin header	M20-9980645	Harwin
24	0		J3,J4	HEADER 5X2	Pin header	M20-9980545	Harwin
25	0		J5	HEADER 4	Pin header	M20-9990445	Harwin
26	1	LED1		Red	LED	KS DELPS1.22-TIVH-68-H3Q4	OSRAM
27	1	LED2		Green	LED	KP DELPS1.FP-UGVI-34-Z555	OSRAM
28	1	L1		EMI filter	Ferrite bead	MI0805K400R-10	Laird
29	1	RTD1		Pt100	RTD	PTS060301B100RP100	Vishay
30	14	R1,R2,R6,R7,R10,R11,R17,R18,R68,R70,R74,R88,R98,R99	R67,R73,R75,R86,R87	0	Resistor	RK73Z1JTDD	KOA
31	1	R4	R3	5.1k, 0.1%, 15ppm	Resistor	ERA3-APB512V	Panasonic
32	3	R12,R95,R96	R5	390	Resistor	RK73B2ATTD391J	KOA
33	8	R8,R9,R13,R14,R15,R16,R19,R20		1k	Resistor	RK73H1JTDD1001F	KOA
34	11	R22,R23,R48,R49,R50,R58,R59,R66,R89,R90,R91	R21,R24,R25,R57,R62,R63	0	Resistor	RK73Z1ETTP	KOA
35	8	R26,R27,R28,R29,R60,R61,R69,R93	R30,R31,R32,R71,R72,R92	10k	Resistor	RK73B1JTDD103J	KOA
36	20	R33,R34,R35,R36,R37,R38,R39,R40,R41,R42,R43,R44,R45,R46,R47,R64,R65,R82,R83,R94		33	Resistor	RK73B1ETTP330J	KOA
37	1	R51		3k	Resistor	RK73B1JTDD302J	KOA
38	1	R52		0	Resistor	RK73Z2ATTD	KOA
39	1	R53		68k	Resistor	RK73H1JTDD6802F	KOA
40	1	R54		22k	Resistor	RK73H1JTDD2202F	KOA
41	1	R55		200k	Resistor	RK73B1JTDD204J	KOA
42	1	R56		3.9k	Resistor	RK73B1JTDD392J	KOA
43	1	R77		120	Resistor	RK73B2ATTD121J	KOA
44	4	R78,R79,R80,R81		4.7k	Resistor	RK73B1JTDD472J	KOA
45	2	R84,R85		100	Resistor	RK73B1JTDD101J	KOA
46	1	R97		220	Resistor	RK73B2ATTD221J	KOA
47	0		SO1,SO2,SO3,SO4,SO5,SO6,SO7,SO8,SO9,SO10,SO11,SO12,SO13		Solder link (Open)		
48	0		SS1		Solder link (Short)		
49	2	SW1,SW2			TACT switch	FSM1LPAS	TE Connectivity
50	1	TH1		M3	Through hole tap	TH-1.6-M3	MAC8
51	0		TH2,TH3,TH4,TH5	M2	Through hole tap	TH-1.6-M2	MAC8
52	2	TP1,TP4,	TP2,TP3,TP5,TP6,TP7,TP8,TP9,TP10	φ 0.8	Test point	LC-22-G(Black)	MAC8
53	1	U1		AFE mounted 32-bit MCU	IC	RX23E-A	Renesas
54	1	U2		LDO, Output 2.5 to 12V, 150mA	IC	ISL80410IBEZ-T7A	Renesas
55	1	U3		USB to UART interface	IC	FT232RL	FTDI
56	1	U4		RS-485, half duplex, full fale-safe	IC	ISL3159EFUZ	Renesas
57	1	U5		CAN transceiver	IC	MAX13053ASA+	Maxim
58	1	Y1		8MHz, 100ppm	Crystal oscillator	NX5032GA-8.000M-STD-CSU-1	NDK
M1	4			Polyacetal, both-sides female spacer	Spacer	AS-310	Hirosugi
M2	4			Polycarbonate, M3 6mm	Screw	PC-0306	Hirosugi
M3	8			2 position, 2.54mm pitch	Jumper socket	M7582-05	Harwin
M4	2			4 position, 2.54mm pitch consolidated	Jumper socket	JS-42060-02	Hirosugi
M5	1			Stainless, M2 12mm	Flat head screw	UF-0212	Hirosugi
M6	1			Stainless, M2	Hexagon nut	UNT-02	Hirosugi

※Manufacturer Part Nameは参考情報です。予告なく変更される場合があります。

Manufacturer Part Name is for reference purposes only. It is subject to change without notice.

Revision History	RSSKRX23E-A User's Manual
------------------	---------------------------

Rev.	Date	Description	
		Page	Summary
1.00	Nov.20.19	—	First Edition issued
1.10	Mar.30.20	1,6,7, 11,12, 14,15, 33	Sentence expression revised
		Appen- dix iv	Parts changes (Manufacturer Part Name) No.1 FFKDS/H-2,54 x1, FKDSA1/H-5,08 x1 →FFKDSA1/H-2,54-2 No.2 FFKDS/H-2,54 x12, FFKDSA1/H-5,08 x1 →FFKDSA1/H-2,54-13

RSSKRX23E-A User's Manual

Publication Date: Rev.1.00 Nov.20.19
Rev.1.10 Mar.30.20

Published by: Renesas Electronics Corporation

RSSKRX23E-A



Renesas Electronics Corporation

R20UT4542EJ0110