



IO-Link

Instruction Manual

Ultrasonic Sensor Family U500 and UR18 with IO-Link



Sensor Solutions

Motion Control
Vision Technologies
Process Instrumentation

Instruction Manual for Ultrasonic Sensor Family U500 & UR18 with IO-Link

Content

1	Sensors covered by this manual	4
2	IO-Link Introduction	4
2.1	SIO / Di Mode Mode	4
2.2	IO-Link Communication Mode	5
2.2.1	Cyclic data	5
2.2.2	Acyclic data	5
2.3	IO-Link Device Description (IODD)	5
2.4	Off-Line Parametrization	6
2.5	Adjustable switching sensor (AdSS)	6
3	Sensor in the IO-Link Communication Mode	7
3.1	Signal Path	7
3.2	Process Data	8
3.2.1	Process Data-In	8
3.2.2	Process Data-Out	9
4	Parameter	10
4.1	System Commands	10
4.2	Measurement Data Channel (MDC)	10
4.2.1	Measurement Value Distance	10
4.2.2	Switch Counts	10
4.2.3	MDC Source	11
4.2.4	MDC Unit Code	11
4.2.5	MDC Setpoint limit	11
4.3	Switching Signal Channel (SSC)	12
4.3.1	Setpoints SP	12
4.3.2	SSC Configuration	14
4.3.3	Timefilter	18
4.3.4	Counter / SSC4	22
4.4	Signal Processing	24
4.4.1	Moving Average Filter	24
4.4.2	Sonic Cone Adjustment	25
4.4.3	Disruption Filter	25
4.5	Quality Parameters	26
4.6	Temperature Settings	26
4.7	Output Settings	27
4.7.1	Switching Output	27
4.7.2	Analog Output	28
4.7.3	Input Mode of Pin 5	29
4.8	Local User Interface	31
4.8.1	Indication LEDs	31
4.8.2	Teach Mode (Local, by wire)	32
4.8.3	qTeach Lock	33
5	Teach Commands	33
5.1	Teach Channel Selection & Teach Status	34
5.2	Static	34

5.2.1	Single Point / 1-Point Teach	35
5.2.2	Window Teach	35
5.3	Static Analog out.....	36
6	Diagnosis.....	37
6.1	Device Status.....	37
6.2	Device Temperature.....	37
6.3	Power Supply Voltage	38
6.4	Bootcycles	38
6.5	Operation Time	38
6.6	Histogram	39
6.6.1	Device Temperature.....	40
6.6.2	Power Supply.....	40
6.6.3	Process Value 1: Distance.....	41
7	Glossar	42

1 Sensors covered by this manual

These instructions apply to the following sensor versions:

U500.xyz.2-XXX

UR18.xyz.2-XXX

2 IO-Link Introduction

IO-Link is an IO technology standardized worldwide according to IEC 61131-9. It permits manufacturer-independent digital, bidirectional point-to-point communication. For this purpose, sensors are connected to the IO-Link master via standardized 3-wire plug-in cables. IO-Link is available for various sensor technologies and can also be integrated into small miniature sensors. See also [here](#) for more information.

With the IO-Link master, which bundles several sensors, the connection to the controller is made via the respective fieldbus system. In addition, an Ethernet-based connection (with OPC UA) from the master allows direct communication from the sensor to IT systems. IO-Link masters are available as field devices for decentralized mounting or as versions for mounting in control cabinets. Many control suppliers also offer IO-Link input terminals and thus an IO-Link master implemented directly on the control. The maximum cable length between sensor and master is 20 m. However, significantly longer connections from the sensor to the controller can be realized by connecting a field master to a field bus system. This gives them maximum flexibility in the connection solution.

As a member of the IO-Link Consortium, Baumer is involved in developing the standard and is one of the first manufacturers to feature the new Smart Sensor Profile 1.1. in its sensors.

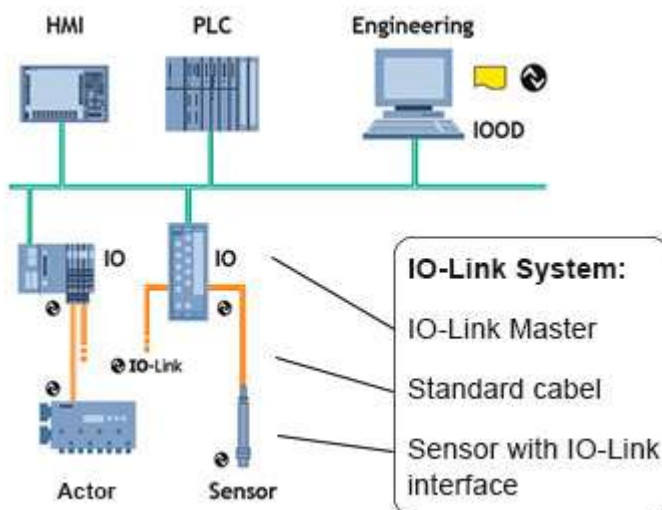

Figure 1 Example of a system architecture using IO-Link

2.1 SIO / Di Mode

Each port of the IO-Link master can be operated either in SIO mode (standard in-out mode: according to the latest specification DI mode for sensors and DQ mode for actuators) or in IO-Link mode and thus process the information of all sensors. In SIO mode, the binary switching output (NPN, PNP or push-pull) of the sensor is used. In IO-Link mode, the output of the sensor (pin 4) is used as a bidirectional, digital interface to exchange measurement and diagnostic information.

2.2 IO-Link Communication Mode

The IO link communication mode is initiated by the master (PLC) with a standardized command sequence, this sequence is called “wake-up”. After successful completion of the wake-up sequence the IO link communication starts.

Data is the most important basis for process and product optimization. With the help of IO-Link, valuable additional data can be made accessible. Sensor and Master can exchange two different types of data (cyclic and acyclic data).

More information can also be found [here](#).

2.2.1 Cyclic data

Transmitted in real time. They are used for process control in the automation system. These can also be transferred to other IT systems via IO-Link.

2.2.2 Acyclic data

Through this data stream, sensors (IO devices) can be parameterized. Additionally this data stream also allows to transmit data for identification and analyzation. The figure below shows the different types of data and their value for the application.

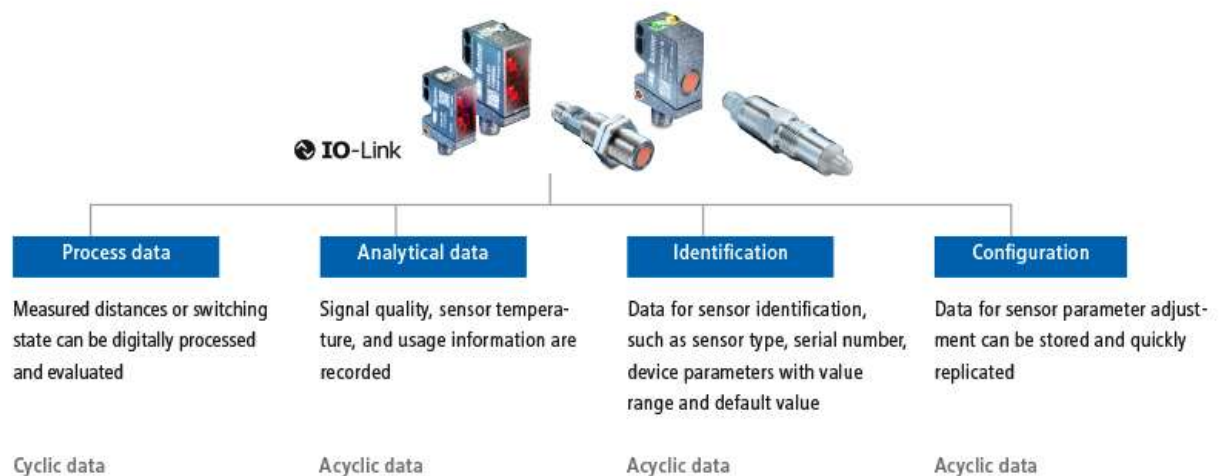

Figure 2 Different IO Link data streams

2.3 IO-Link Device Description (IODD)

Each IO-Link Device has a device description file, the so-called IODD (IO Device Description). This contains data about the manufacturer, article number, functionality, software version etc., which can be easily read out and further processed by the automation system. Each device, i.e. each sensor, can be uniquely identified both via the IODD and via an internal device ID. The identification data of the sensor also includes device or application descriptions that can be freely assigned by the user. The IODD consists of several files: a main file and optional external language files (both in XML format), as well as image files (in PNG format).

2.4 Off-Line Parametrization

Off-line sensor parameter adjustment via convenient user interfaces in the PC (via USB Master) or via Wireless App (via Wireless Master). Sensors can be conveniently configured at the desk and installed without further teach-in.

Even if IO-Link is not implemented in the machine control, sensors can be operated in SIO mode and use this advantage

2.5 Adjustable switching sensor (AdSS)

Additionally, the sensors described in this manual can be operated as “adjustable switching sensors (AdSS)” according to the Smart Sensor Profile. When treated as AdSS the sensors-Master communications happens via a fully standardized command set. Thus operation without IODD file is possible.

3 Sensor in the IO-Link Communication Mode

3.1 Signal Path

The signal path describes the rough position of a parameter in the signal processing chain. The path starts with the measuring value in the top left corner and finishes either with a physical pin (top right) or as output via the process data (bottom right).

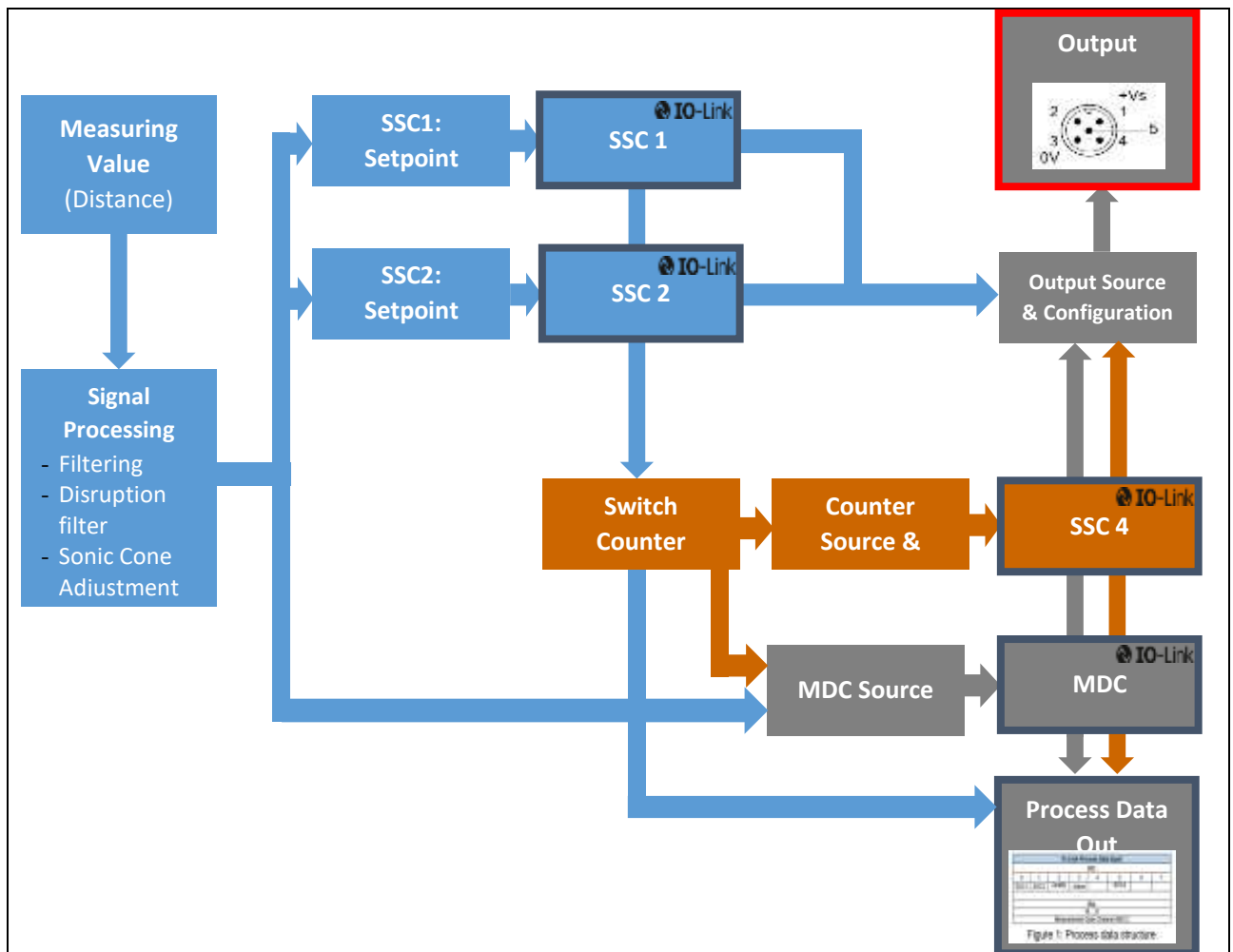

Figure 3 Illustrates the signal path from raw data to an output either through a physical pin (top right) or as output via the process data (bottom right)

3.2 Process Data

With the sensor in the IO-Link communication mode, process data is cyclically exchanged between the IO-Link master and the device. Process data is exchanged to and from the sensor (Sensor \leftrightarrow Master). The master does not need to explicitly request these process data.

3.2.1 Process Data-In

Process Data-In is sent from the sensor to the master (Sensor \rightarrow Master). As shown in Figure 4 **Process data Input**, the Process Data Input is an 48bit string and structured according to the Smart Sensor Profile definition PDI48.INT32_INT8.

IO-Link Process Data Input											
47	16	15	8	7					0		
IntegerT(32)		IntegerT(8)		8 bit							
Measurement value (MDC)		Scale		Baumer specific							
				7	6	5	4	3	2	1	0
						SSC4		Alarm	Quality	SSC2	SSC1

Figure 4 Process data Input

Bit 0/Bit 1: SSC1/SSC2 (Switching Signal Channel 1 & Channel 2)

These bits are the digital representation of the switching outputs.

Bit1 = 0 \rightarrow There is no object within the switching range (Logic: Normal)

Bit1 = 1 \rightarrow An object lies within the switching range (Logic: Normal)

See section 4.3 to learn how to configure this bit

Bit 2: Quality

This bit provides information about the quality of the sonic echo reflected by the object.

Bit2 = 0 \rightarrow Sensor has enough signal to reliable detect an object

Bit2 = 1 \rightarrow The reflection detected from the sensor is critical, it is recommended to check sensor in the machine.

Sensor might be badly aligned or dirty. See section 4.5 to learn how to configure this bit.

Bit 3: Alarm

The alarm bit indicates that there is a problem with the configuration or function of the sensor.

Bit3 = 0 \rightarrow Sensor operates properly.

Bit3 = 1 \rightarrow A problem with either the sensor configuration or function was detected.

Bit 5: Switching Signal Channel 4 (SSC4), Switch Counter Function

By configuring SSC4, it is possible to set up a binary signal related to the number of switchcounts of SSC1 or SSC2. An auto-reset and timefilters are included, to be able to create a full-featured counter being able to count lot sizes without any need to code software on the PLC.

See section 4.3.4 to learn how to configure this bit.

Bit 8 to 15: Scale

Value is the exponent to the power of ten, applicable to the value of the Measurement Data Channel (MDC)

Example:

- Value of MDC 1000
- Unit m
- Scale -6
- Means $1000 \cdot 10^{-6}$ m or 1000 μ m

Bit 16 to 47: MDC

MDC stands for measurement data channel. Via this channel the distance value or the switch counts of SSC1, 2 or 4 can be read out as 32 bit integer value. See section 4.2 to learn how to configure the MDC.

3.2.2 Process Data-Out

This data is cyclically sent from the master to the sensor (Master→Sensor).

IO-Link Process Data Output							
Bit:							
7	6	5	4	3	2	1	0
					Trigger	Find Me (Localization: LEDs flashing)	Disable Transducer

Bit 0: Disable Transducer

By changing this bit the transducer is disabled. This switches off the sensing element without switching off the electronics. The sensor will not deliver a measurement or switching value. This can be useful to measure neighbouring sensors sequentially.

Bit 0 = 0 → Transducer is enabled

Bit 0 = 1 → Transducer is disabled

Bit 1: Find Me Function

Signalling e.g. by flashing LEDs (green, yellow, and red) on the sensor to locate and physically identify a sensor in a machine or system. The signalling can be triggered, for example, from the engineering tool of the controller.

Bit 1 = 0 → Find Me Function is deactivated

Bit 1 = 1 → Find Me Funktion is activated, LEDs are flashing.

Bit 2: Trigger

Via this Bit it is possible to trigger a single measurement from the sensor. For this Bit to have a function the DI/DO Settings.Input Mode has to be set to Trigger see 4.7.3.4. This is very useful when many sensors are mounted next to one another and do influence each other. Using this mode no additional wires are needed in order to sequentially measure on multiple sensors.

Bit 2 = 0 → Trigger is disabled, the sensor does not measure and the sensor element is deactivated

Bit 2 = 1 → Trigger is enabled, the sensor measures edge-triggered and the sensor element is activated.

4 Parameter

4.1 System Commands

A factory reset of the sensor activates the default parameters as programmed in the factory. All parameters changed by the user will be lost. The factory reset can also be triggered via local teach-in (qTeach or wire teach) directly at the sensor (see assembly instruction for more information) where only the parameters that are changed via teach-in will be reset.

Parameter name	Short Description	Rights	Unit / Allowed values
Standard command	Restore Factory Settings	wo	

4.2 Measurement Data Channel (MDC)

4.2.1 Measurement Value Distance

Parameter name	Short Description	Rights	Unit / Allowed values
Measurement Value. Distance	Process value for distance	ro	mm

4.2.2 Switch Counts

For each individual SSC a switching counter is implemented, which can be used as diagnosis data or also as measurement value. The number of counts of each channel can also be mapped to the measurement data channel MDC by adjusting the MDC source. Trigger of counter is on positive slope of related SSC.

Parameter name	Short Description	Rights	Unit / Allowed values
- SSC1 Switch Counts Reset - SSC2 Switch Counts Reset - SSC4 Switch Counts Reset	Command to set the counter value of the SSC to zero	wo	
- Switch Counts.SSC1 Resettable - Switch Counts.SSC2 Resettable - Switch Counts.SSC4 Resettable	Total number of switch counts on SSC1 (resettable by user command-> SSC1 Switch Counts Reset) Available for SSC1,2 and 4.	ro	32 Bit value

4.2.3 MDC Source

Selects which measuring value is mapped to the MDC channel and is then available via the process data-IN path. When SSC1, SSC2 or SSC4 is selected the number of switches detected by the channel is shown.

Parameter name	Short Description	Rights	Unit / Allowed values
MDC Selection.Source	Select the process value that is shown on the MDC channel	ro	<ul style="list-style-type: none"> - Distance (Default) - Switch Counter SSC1 - Switch Counter SSC2 - Switch Counter SSC4

4.2.4 MDC Unit Code

Parameter name	Short Description	Rights	Unit / Allowed values
MDC Descriptor.Unit code	Indicates the unit of the selected MDC source	ro	

4.2.5 MDC Setpoint limit

This parameter allows to read out the limits of the measuring range of the sensor.

Parameter name	Short Description	Rights	Unit / Allowed values
MDC Descriptor.Lower limit	Lower value of measuring range, if value is below out of range is shown	ro	A0: 50 mm
MDC Descriptor.Upper limit	Upper value of measuring range, if value is above out of range is shown	ro	A0: 1500 mm

4.3 Switching Signal Channel (SSC)

The sensor features three different switching channels. Switching Signal Channels SSC1 and SSC2 are reserved for distance measurements, whereas Switching Channel 4 has a counter function with an auto-reset. All switching channels can be adjusted via IO-Link. All switching channels can be mapped to the MDC as well. Then they will show the counts detected by the channel.

For more information about how to set-up the Counter/SSC4 channel and its behavior, please see section 4.3.4.

4.3.1 Setpoints SP

Using this parameter the user can modify the switchpoint of the sensor by entering the distance value at which the sensor should switch (teach-by-value function). For the reflex barrier the parameter "Reflector.Position" defines the position of the reflector. **Figure 5** shows the illustration of the switch point. For Single point mode only SP1 is relevant, SP2 is not active. For the Window mode SP1 & SP2 are active. The switching modes are explained in section 4.3.2.1

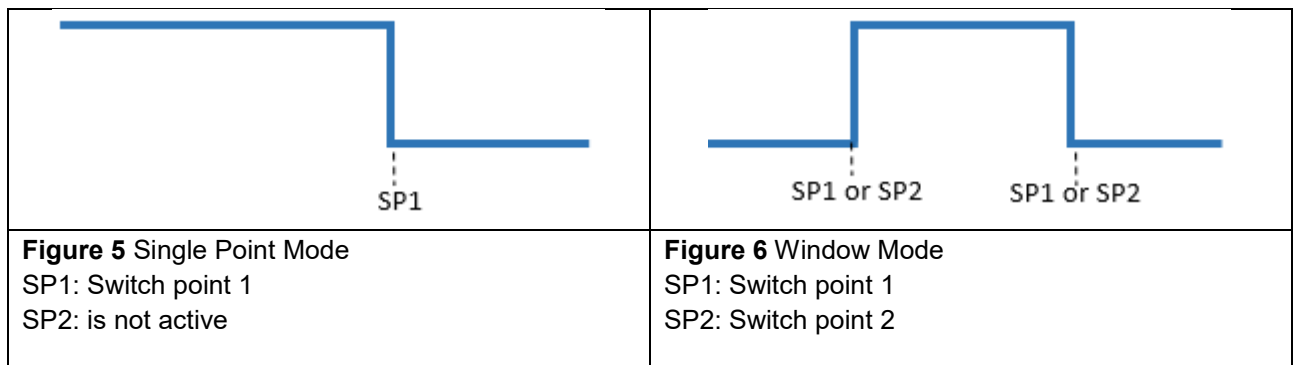

Parameter name	Short Description	Rights	Unit / Allowed values
SSC1 Param.SP 1	Set the distance at which the related SSC is set to active (or inactive if inverted)	rw	Limits: A0: 50 to 1500mm, Default SP1 1000mm,
SSC1 Param.SP 2	Set the distance at which the related SSC is set to inactive (or active if inverted). Only active if SSC is set to window mode	rw	Limits: A0: 50 to 1500mm, Default SP2 70mm,



The parameters "Reflector.Position" and "Reflector.Tolerance" apply exclusively to the reflection barrier under the condition that the window switch for SSC1 is activated.

Parameter name	Short Description	Rights	Unit / Allowed values
SSC1 Param.SP 1	Set the lower limit of the Reflector Position. The reflector can change the position between lower and upper limit.	rw	Limits: A0: 50 to 1500mm, Default SP1 , 950mm,
SSC1 Param.SP 2	Set the upper limit of the Reflector Position. The reflector can change the position between lower and upper limit.	rw	Limits: A0: 50 to 1500mm, Default SP2, 1050mm,
Reflector.Position	Select the reflector position, works together with the parameter Reflector tolerance. (SP1=ReflectorPosition*(1-	rw	Limit: 100 to 1250mm Default 1000 mm

	ReflectorTolerance; $SP2 = \text{ReflectorPosition} * (1 + \text{ReflectorTolerance})$		
Reflector.Tolerance	Select the reflector tolerance, works together with the parameter Reflector position. The reflector tolerance is selectable between 1 and 20 %. It sets the tolerance window symmetrically around the reflector position. The upper and lower tolerance can be read off at SP1 and SP2.	rw	Limit: 1... 20% Default: 5%

4.3.2 SSC Configuration

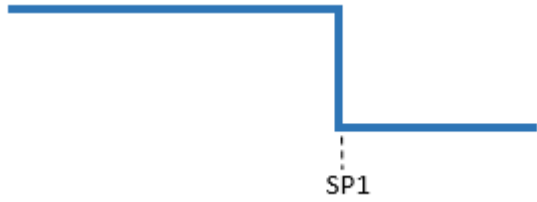

4.3.2.1 Switching Mode

	
<p>Figure 7 Single point</p> <p>A single switchpoint (SP1) is defined at which the sensor switches.</p>	<p>Figure 8 Window Mode</p> <p>The sensor switches within a range defined by two different setpoints (SP1 and SP2)</p>

Parameter name	Short Description	Rights	Unit / Allowed values
SSC1 Config.Mode	Selects the SSC switch mode	rw	-Disabled -Single Point (Default) -Window

4.3.2.2 Channel Logic

Allows to change the output logic from Normally Open (NO, Normal) to Normally closed (NC, Inverted).

	
<p>Figure 9 «Normal» or NO setting</p> <ul style="list-style-type: none"> - The output is high, when the object is within the range defined by the setpoints. - The output is low when the object is not present outside of the range defined by the setpoints 	<p>Figure 10 «Inverted» or NC setting</p> <ul style="list-style-type: none"> - The output is high when the object is not present outside of the range defined by the setpoints - the output is low, when the object is within the range defined by the setpoints

Parameter name	Short Description	Rights	Unit / Allowed values
SSC1 Config.Logic	Selects the SSC logic. It can be changed between "active if object is present (normal)" or "inactive if object is present (inverted)"	rw	- Normal (NO) (Default) - Inverted (NC)

4.3.2.3 Hysteresis Width

The hysteresis is configured in percent of the switch point distance. It is the difference between switch point and reset point (see Figure 11). This parameter can be beneficial to smoothen out signals when samples have quickly changing positions.

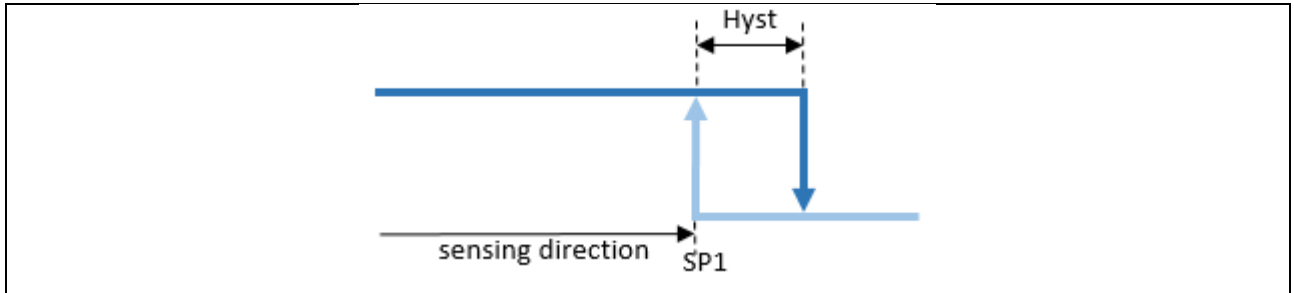

Figure 11 Hysteresis is the difference between switch point and reset point

- Bright blue: object moving from far to close distance (in this case switch point)
- Dark blue: moving from close to far distance (in this case reset point)

Parameter name	Short Description	Rights	Unit / Allowed values
Hysteresis.SSC1 Width	Adjust hysteresis width as percent of the switch point distance	rw	Limits 0 ... 99 %, Default 4%

4.3.2.4 Hysteresis Alignment Mode

In case of axial detection tasks like stop trigger or level detection, an accurate switching distance is required. To adapt the switching behavior and the hysteresis to the movement direction of the object, the alignment of the hysteresis can be changed.

Hysteresis settings are available for .P, D and .R types.

Parameter name	Short Description	Rights	Unit / Allowed values
SSC1 Config.Hyst	Selects the hysteresis alignment mode	rw	<ul style="list-style-type: none"> - Left Aligned - Center Aligned - Right Aligned (Default)

4.3.2.4.1 Left Aligned

Left Aligned defines the hysteresis to be aligned towards the sensor / against the sensing direction.

When to apply?

- For an accurate switching distance in case the object is moving away from the sensor
 - o Example: Detection of the low level of a tank to avoid a dry-run

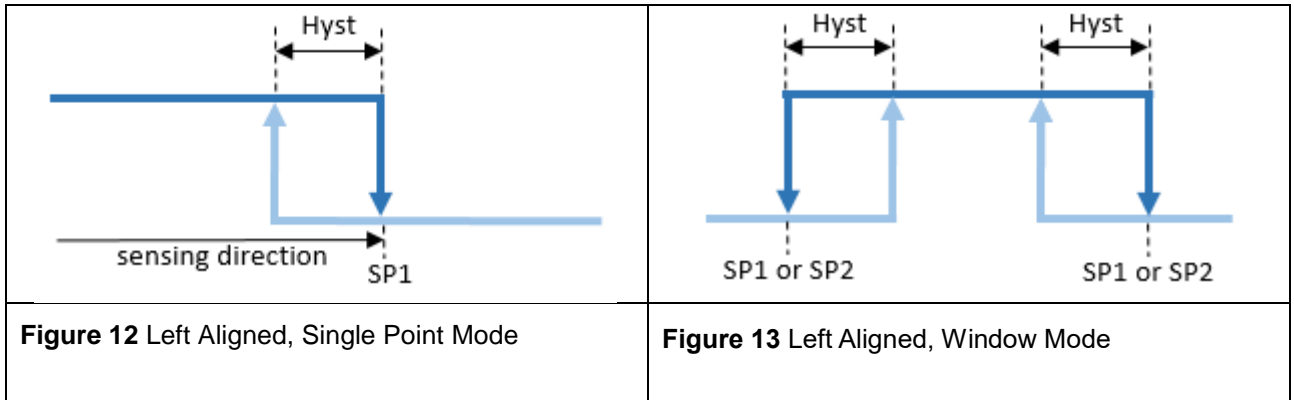

4.3.2.4.2 Right Aligned

Right Aligned defines the hysteresis to be aligned away from the sensor / in sensing direction.

When to apply?

- For an accurate switching distance in case the object is moving towards the sensor.
 - o Example: Stop trigger application, usual detection tasks.

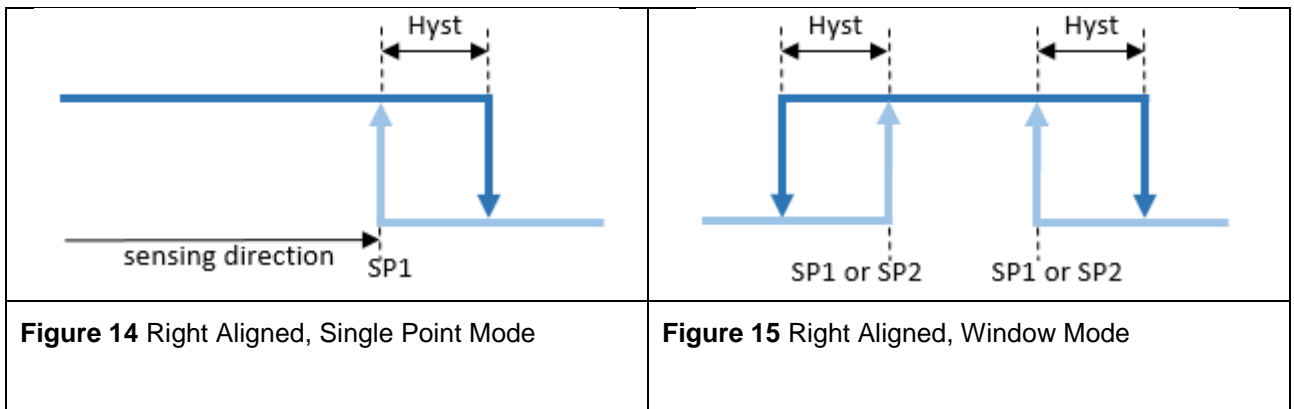

4.3.2.4.3 Center Aligned

A compromise between left and right aligned. The hysteresis is aligned symmetrical around the individual setpoints.

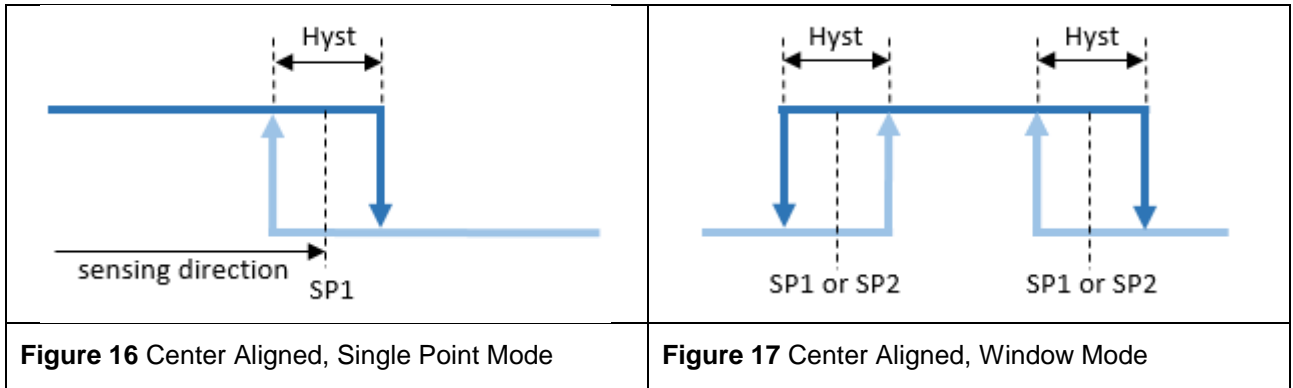

4.3.2.5 Reflector Tolerance

The configuration of the reflector tolerance is only relevant for the reflective barrier (.R types). The reflector tolerance states the relative allowable variance of the reflector position. **Figure 18** shows an example with two different tolerances that can be selected. The two shown reflector tolerances (A and B) correspond to the ones who can be taught via q-teach. With IO-Link the reflector tolerance can be set between 1 and 20%. An object that enters for example area A, will not be detected as the sensor cannot distinguish object and reflector.

Example: Reflector Position of 500 mm ± 5 % means the reflector position ranges from 475 mm to 525 mm.

Benefit: Applications with an unstable background, e.g. conveyors, can be solved.

Disadvantage: Object must be further away from reflector (at least 10 %).

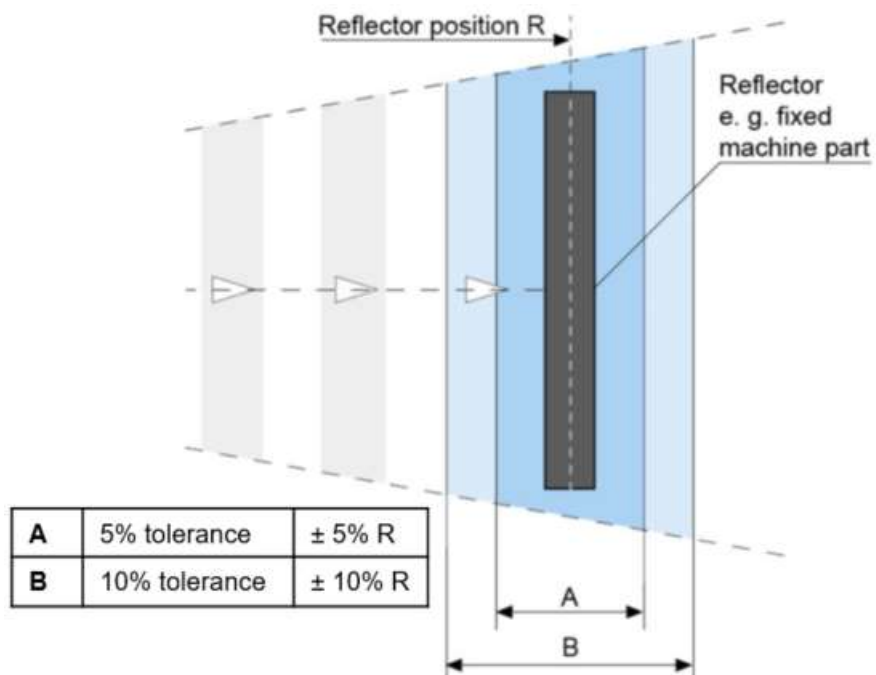

Figure 18: Reflector tolerance reflective barrier

Parameter name	Short Description	Rights	Unit / Allowed values
Reflector Tolerance	Set reflector tolerance as percentage of the sensing range	rw	Limit: 1...20% Default: 5%

4.3.3 Timefilter

This changes the timing of the switching signals, for example to avoid bouncing/suppress false switching operation. The ability to directly parametrize and configure the timing on the sensor itself, removes the need to have additional coding on the PLC or to use pulse stretching adapters.

The described time filters can be configured and applied to each SSC individually.

4.3.3.1 Response Delay Time

The response delay time defines the time, the measurement value needs to be above (single point mode) or inside (window mode) the switchpoints of the related SSC until its status changes to active (or inactive, if the logic is inverted as described in section 4.3.2.1)

When to apply?

- To avoid the detection of small peaks/false switching operations due to structure changes of the background or similar.
- To avoid wrong switching of known disturbances such as the wheel of a mixer
- To avoid bouncing.
- To optimize the timing of the execution of a subsequent actor triggered by the output of the sensor.

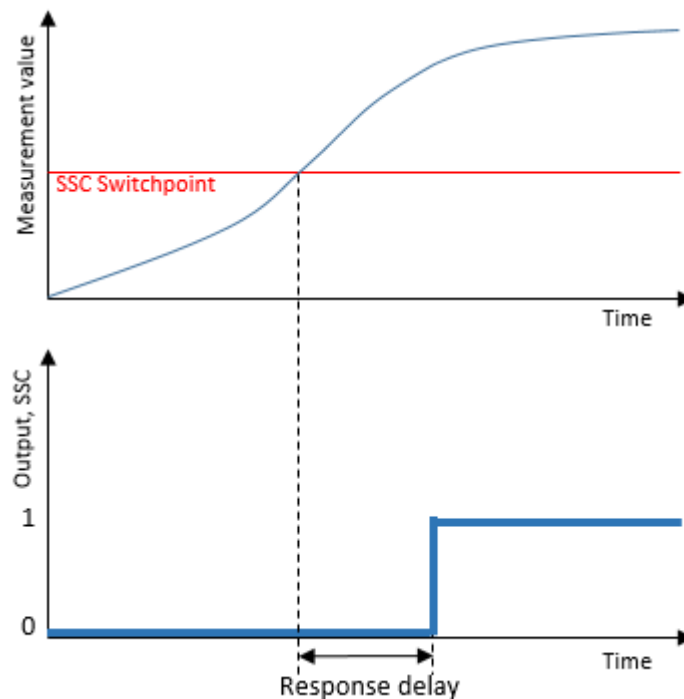

Figure 19: Response Delay

Parameter name	Short Description	Rights	Unit / Allowed values
Response Delay.SSC1 Time	Sets / indicates the response delay time in milliseconds for the respective switching signal channel (SSC).	rw	0 to 60.000 ms Default: 0 ms

4.3.3.2 Release Delay Time

The release delay time defines the time, where the measurement value needs to be below (single point) or outside (window mode) of the switchpoints of the related SSC, until its status is changed to inactive (or active, if the logic is inverted as described in section 4.3.2.1)

When to apply?

- To avoid false switching operations in case of an object which is not 100% stable to detect over the whole length
- To suppress short losses of a proper signal due to known disturbances such as the wheel of a mixer
- To avoid bouncing.
- To optimize the timing of the execution of a subsequent actor triggered by the output of the sensor.
- To detect a unwanted gap size within a continuous flow of products.

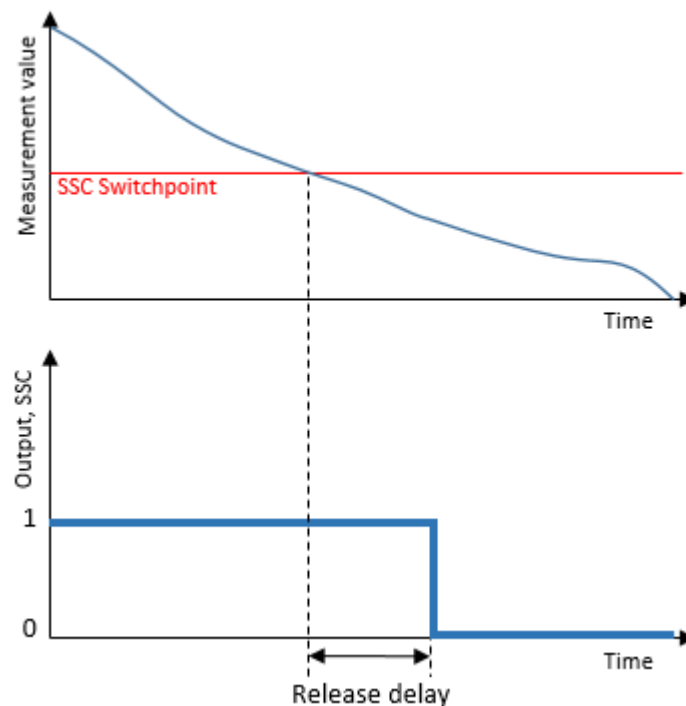

Figure 20: Release Delay

Parameter name	Short Description	Rights	Unit / Allowed values
Release Delay.SSC1 Time	Sets / indicates the release delay time in milliseconds for the respective switching signal channel (SSC).	rw	0 to 60.000 ms Default: 0 ms

4.3.3.3 Minimal Pulse Duration

The minimal pulse duration defines the minimum time, the switching signal of the related SSC stays active or inactive after the change of its status.

This parameter can be applied on

- both slopes / active and inactive
- positive slope / active (or inactive, if the logic is inverted as described in section 4.3.2.1)
- negative slope / inactive (or active, if the logic is inverted as described in section 4.3.2.1)

When to apply?

- To align the timing of the sensor to a slower PLC.
- To avoid bouncing.
- To avoid false pulses due to short losses of a proper signal.
- To straighten the clock / pace

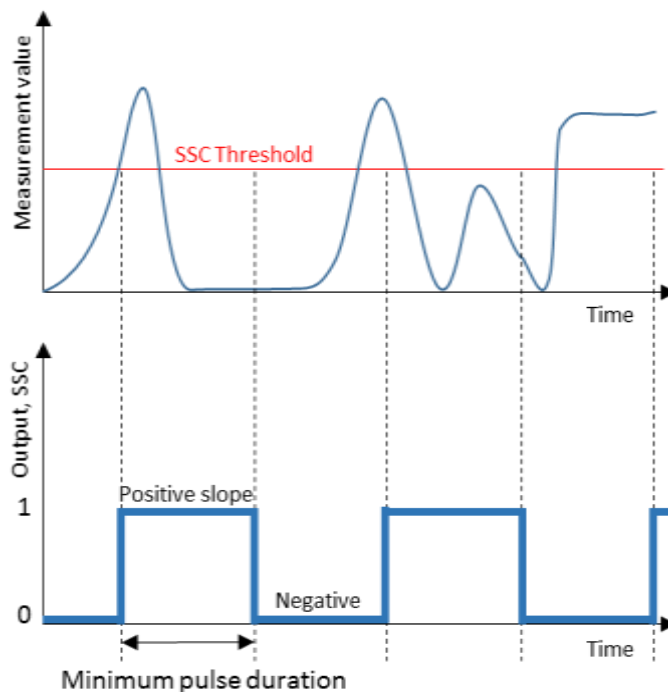

Figure 21 Minimum Pulse Duration

Parameter name	Short Description	Rights	Unit / Allowed values
Minimal Pulse Duration.SSC1 Time	Sets / indicates the minimal pulse length in milliseconds for the respective switching signal channel (SSC).	rw	0 to 60.000 ms Default: 0 ms
Minimal Pulse Duration.SSC1 Mode	0: Both Pulses: positive and negative pulses are prolonged; 1: Positive Pulse: only positive pulses are prolonged; 2: Negative Pulse: only negative pulses are prolonged	rw	-Both Slopes (Default) -Positive Slope -Negative Slope

4.3.4 Counter / SSC4

For each individual SSC a switching counter is implemented, which can be used as diagnosis data or also as measurement value. The number of counts of each channel can also be mapped to the measurement data channel MDC by adjusting the MDC source (See section 0).

Trigger of counter is on positive slope of related SSC.

By configuring SSC4, it is also possible to set up a binary signal related to the number of switchcounts of SSC1 or SSC2. An auto-reset and timefilters are included, to be able to create a full-featured counter being able to count lot sizes without any need to code software on the PLC.

As all SSCs, SSC4 can also be mapped to the digital output giving the possibility to create a stand-alone lot-size counter.

In section 3.1, the signal path is described more detailed, to illustrate how the counter module is implemented. In section 4.3.4.2 the behavior depending on the configuration is explained.

4.3.4.1 SSC4 Configuration

In general the SSC4 offers the same features as the SSC1 and SSC2 based on distance (See 4.3.2), including also timefilters.

Exceptions:

- No hysteresis settings as there are only incremental counts.
- Additional parameters to adjust like *SSC4 Source* and *SSC4 Auto-Reset*.

Parameter name	Short Description	Rights	Unit / Allowed values
SSC4 Param.SP1	Set the number of counts at which the SSC is set to active (or inactive if inverted)	rw	0 ... max = 2147483639 Counts, default 20
SSC4 Param.SP2	Set the number of counts at at which the SSC is set to inactive (or active if inverted). only active if SSC is set to window mode	rw	0 ... max = 2147483639 Counts, default 0

Parameter name	Short Description	Rights	Unit / Allowed values
SSC4 Config.Logic	Selects the SSC logic. It can be changed between active if object is present (normal) or inactive if object is present (inverted)	rw	- Normal (Default) - Inverted
SSC4 Config.Mode	Selection of the switching mode	rw	- Disabled - Single Point (Default) - Window
SSC Source Settings.SSC4 Selection	Select the switch counter that is used as input of SSC4	rw	- SSC1 Switch Counter (Default) - SSC2 Switch Counter
SSC Source Settings.SSC4 Auto Reset	Auto Reset of switch counter if value in SSC4 Param.SP1 is reached	rw	- Enabled (Default) - Disabled

Parameter name	Short Description	Rights	Unit / Allowed values
Release Delay.SSC4 Time	Sets / indicates the release delay time in milliseconds for the respective switching signal channel (SSC).	rw	0 to 60.000 ms Default: 0 ms
Response Delay.SSC4 Time	Sets / indicates the response delay time in milliseconds for the respective switching signal channel (SSC).	rw	0 to 60.000 ms Default: 0 ms
Minimal Pulse Duration.SSC4 Time	Sets / indicates the minimal pulse length in milliseconds for the respective switching signal channel (SSC).	rw	0 to 60.000 ms Default: 0 ms
Minimal Pulse Duration.SSC4 Mode	0: Both Pulses: positive and negative pulses are prolonged; 1: Positive Pulse: only positive pulses are prolonged; 2: Negative Pulse: only negative pulses are prolonged	rw	-Both Slopes (Default) -Positive Slope -Negative Slope

4.3.4.2 SSC4 Behavior

By enabling autoreset, a full-featured counter being able to count lot sizes can be created without any need of a manual reset.

Timefilters like *Response Delay* can help to optimize the timing of the execution of a subsequent actor.

Figure 22 illustrates the behavior of SSC4 using different setting. SSC4 source is hereby the switchcounter of SSC1.

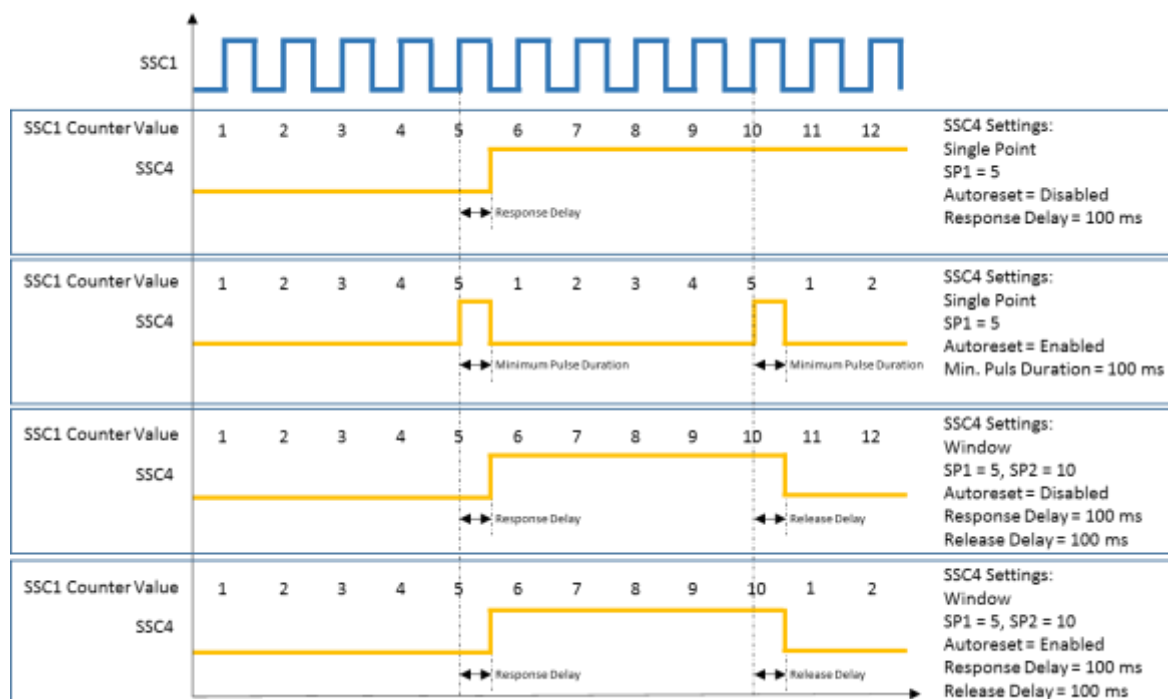

Figure 22: Behavior SSC4/Counter: Single-Point or Window, Autoreset enabled or disabled

4.4 Signal Processing

4.4.1 Moving Average Filter

This parameter is valuable for more experienced users or to fine tune the trade-off between accuracy and measurement speed. A reduced accuracy can be caused by weak reflecting objects, by fast temperature variations of the environment or wind disturbances. The negative results of these effects can be reduced with the moving average filter. As the moving average filter averages multiple values, it leads to an increased response time. When the parameter is set to 12ms the filter is deactivated and no values are averaged. The figure below shows an example.

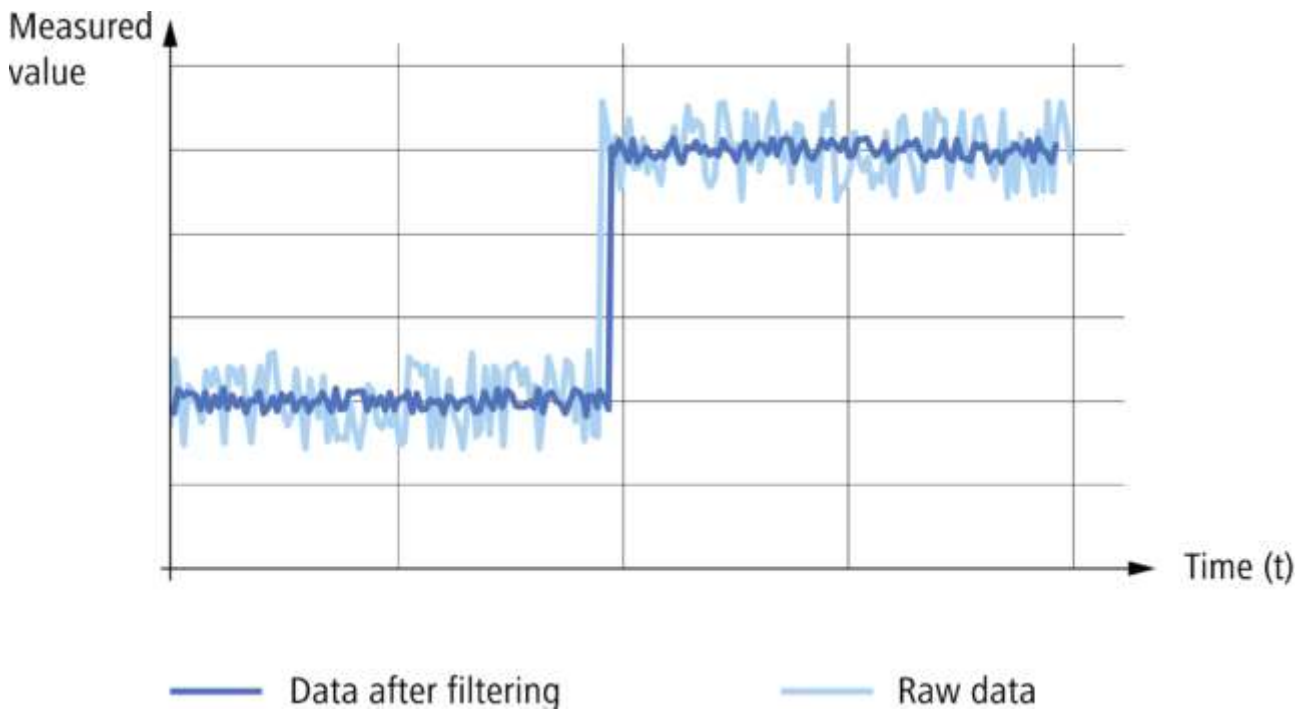

Figure 1: Signal processing moving average filter

Parameter name	Short Description	Rights	Unit / Allowed values
Process Value Moving Average Filter.Length	Selects the length of the moving average filter over which values are averaged, it does not affect the cycle time.	rw	Limits: 12 bis 360ms, Default 12 ms

4.4.2 Sonic Cone Adjustment

Via this parameter the width of the sonic cone is modified. This is useful to measure reflections from weak reflections objects (setting "wide") or to measure through narrow openings (setting "narrow").

Parameter name	Short Description	Rights	Unit / Allowed values
Beam Forming.Sonic Cone Adjustment	Set the width of the sonic cone	rw	- narrow - medium (Default) - wide

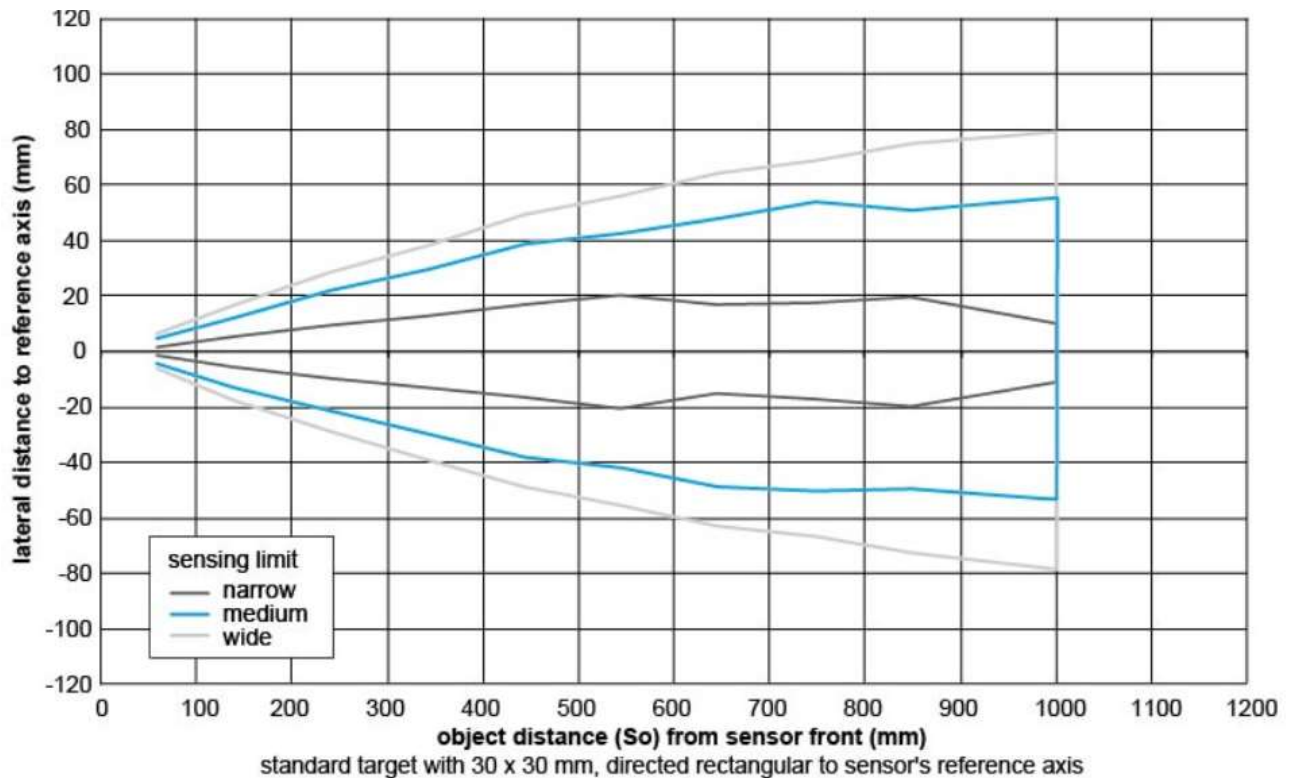

Figure 2: Sonic cone Input Mode adjustment

4.4.3 Disruption Filter

This filter allows you to ignore interfering objects when passing through the measuring range either cyclic or non-cyclic. This function depends on two parameter

Parameter name	Short Description	Rights	Unit / Allowed values
Process Value Disruption Filter.Maximum perturbation time	Duration (in units of time) until a signal (as defined in the parameter . Distance) becomes visible at the output.	rw	Limits: 0 to 10.000ms Default: 24ms
Process Value Disruption Filter.Distance	Distance deviations from the current measured value which are ignored, if shorter than the period set by the parameter '. Maximum perturbation time.	rw	Limits 5mm to 1000mm, Default: 50 mm

4.5 Quality Parameters

This parameter indicates the signal strength from the received reflection relative to the set threshold. It is useful to be monitored by the PLC to detect weak signals which may be caused by misalignment or by dirt on the sensor surface.

Parameter name	Short Description	Rights	Unit / Allowed values
Quality.Value	Quality value indicates the quality of the reflected signal	ro	units dB
Quality.Bit.Threshold	Selects the Quality Threshold, if the quality value is below the threshold the LEDs start to blink and the quality bit in the process data is set to 1	rw	Limits: 0 to 40 dB, units dB; Default 12 dB

4.6 Temperature Settings

The speed of sound depends strongly on the temperature. Therefore Baumer ultrasonic sensors are temperature corrected. When "internal temperature" is selected, the sensor will use temperature sensors located inside of the sensor to correct for variation in the speed of sound with respect to the ambient temperature. In order to improve the accuracy or to remove the warm up time, it is possible to use an external temperature sensor and set the temperature using the parameter "Temperature Settings.Environment Temperature". When this is done the self heating of the sensor can be made irrelevant. The parameter "Temperature Settings.Enable Environment Temperature" has to be set to "External Temperature".

Parameter name	Short Description	Rights	Unit / Allowed values
Temperature Settings.Enable Environment Temperature	Enable usage of external environment temperature.	rw	External Temperature / Internal Temperature Default: Internal Temperature
Temperature Settings.Environment Temperature	Sets the temperature that is used by sensor to calculate the distance. It is only used when the parameter "Temperature Settings.Enable External Environment temperature" is set to External Temperature.	rw	Limits : -40°C to 85°C Default: 20°C
Unit Selection.Temperature	Select temperature unit (rw parameter in menu Parameter/ Temperature Settings, ro in menu Diagnosis/ Device Temperature)	rw	Kelvin / Celsius / Fahrenheit Default: Celsius
Unit Selection.Time	Select time unit (rw parameter in menu Parameter/ Temperature Settings, ro in menu Diagnosis/ Operating Time)	rw	Second / Minute / Hour Default: Second

4.7 Output Settings

4.7.1 Switching Output

Via this parameter it is possible to select the output circuit of the physical outputs. If set to PushPull, the circuit type (change from NPN to PNP) can also be modified by changing the external load according to the connection diagram, this can be found in the datasheet or in the Assembly Instruction (MAL) of the respective article.

Parameter name	Short Description	Rights	Unit / Allowed values
DI/DO Settings.OUT1 Circuit	Select the output function	rw	- PushPull (default)
DI/DO Settings.OUT1 Mode	Select the SSC channel that is shown on the Pin	rw	- SSC1 (default) - SSC2 - SSC4
DI/DO Settings.OUT2 Circuit	Select the output function	rw	- PushPull (default) - PNP
DI/DO Settings.OUT2 Mode	Select the SSC channel that is shown on the Pin	rw	- SSC1 - SSC2 (default) - SSC4

4.7.2 Analog Output

4.7.2.1 Output Scale

Allows to change the upper and lower values of the analog output range. For example: the default range is 0 to 10 V, this can be modified to 2 to 8V. In terms of distance values mapped to analog values the modification would mean that the default mapping of 0V=70mm and 10 V=1000 mm, is modified to 2V = 70mm and 8V=1000 mm.

When to use: When the master requires a different voltage or current range.

Parameter name	Short Description	Rights	Unit / Allowed values
Analog Output.AnalogMax	Set the maximum value of the analog output	rw	Voltage: 0-10 V, Default 10V Current: 4-20mA, Default: 20mA
Analog Output.AnalogMin	Set the minimum value of the analog output	rw	Voltage: 0-10 V, Default 0V Current: 4-20mA, Default: 4 mA

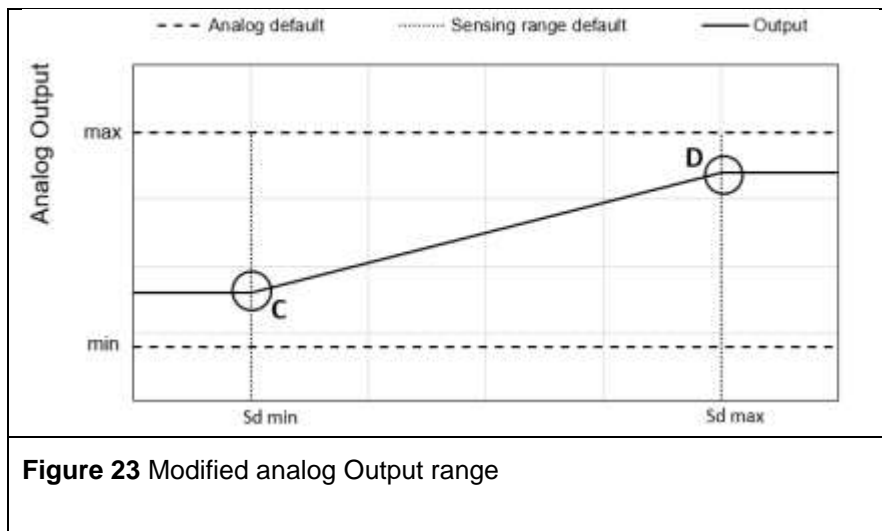

4.7.2.2 Distance at Analog Min/Max

With this parameters the analout output characteristic is modified. By reducing the sensing range the resolution of the analog output is improved. Inverting the analog output can be achieved by setting Analog Max on minimum value (V) of the analog output and AnalogMin on the maximum value (V) of the analog output

When to use: When the resolution of the analog output range should be improved.

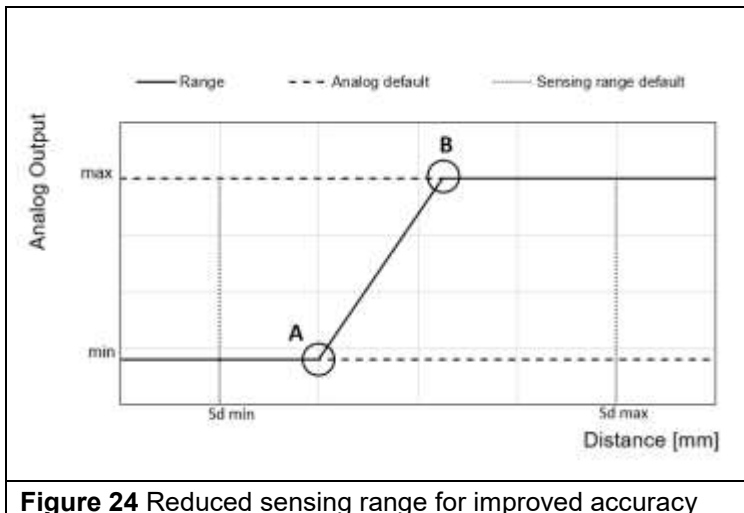

Figure 24 Reduced sensing range for improved accuracy

Parameter name	Short Description	Rights	Unit / Allowed values
Analog Output.Distance@AnalogMin	Set the distance value in mm at the minimum value of the Analog Output	rw	Limit A0: 50 to 1500mm Default: 70mm
Analog Output.Distance@AnalogMax	Set the distance value in mm at the maximum value of the Analog Output	rw	Limit A0: 50 to 1500mm Default: 1000mm

4.7.3 Input Mode of Pin 5

Via the input mode of Pin 5 the user can choose via drop-down menu between Teach-in / Multiplex / Synchronization / Trigger / None Input.

Parameter name	Short Description	Rights	Unit / Allowed values
DI/DO Settings.Input Mode	Select the function of the Input Pin	rw	-None -Teach-In -Trigger -Synchronisation -Multiplexing Default: Teach-In

4.7.3.1 Teach-in

In this mode the sensor can be taught through wire teach. Depending on the sensor type different modes are available. This is explained in the MAL of the corresponding article. The MAL can be found on the product page of each article.

4.7.3.2 Multiplex (MUX) Mode

Link the control pin of both sensors to each other. While the first sensor is measuring, the second is disabled. After the first measurement is completed, the second sensor is allowed to send and receive its signals. In maximum ten sensors can be interconnected. The multiplex function increases the sensor response time, the specified value increases with the number of connected the sensor (number of connected sensors x response time).

4.7.3.3 Synchronization Input Mode (Sync-In.) Mode

Link the control pin of all sensors within a limited area to each other. This triggers the measurement of all sensors at the same time. Interference signals which arrive later at the sensor due to their longer sensing distance, will be ignored. Up to ten sensors can be synchronized via control pin.

Note: If the pin is not in use it must be connected to a defined potential to ensure the standard response time:

- **Input Mode:** Synchronization: Connect the control pin to supply voltage (+Vs)
- **Input Mode:** Multiplex: Connect the control pin to ground (GND)
- **Input Mode:** Teach-In

4.7.3.4 IO-Link triggered

Use this mode to synchronize the sensors via the Process Data-Out Channel (see section 3.2.2 for the process data-out structure, below you can find the structure as well). As long as Bit 2 is high (e.g. 1) the sensor measures for only one measurement cycle. When the bit is set to 0 the sensor will not measure and represent the last measured value on the output pin and in the Process Data-In Channel.

IO-Link Process Data Output							
Bit:							
7	6	5	4	3	2	1	0
					Trigger	Find Me (Localization: LEDs flashing)	Disable Transducer

When to use?

This way of synchronisation is very beneficial in order to reduce the wiring costs. Compared to the other synchronisation options no extra cable is needed.

4.8 Local User Interface

Different parameters are available to configure the local user interface which means the indication LEDs and the local-teach-in (qTeach, teach by wire)

4.8.1 Indication LEDs

Figure 26 shows which LED indicates which status. The relationship between mode/switching output and LED can not be modified, but it is possible to deactivate or to invert the LED behaviour. In addition, the yellow LED continuously works as alignment aid only for the .R types.

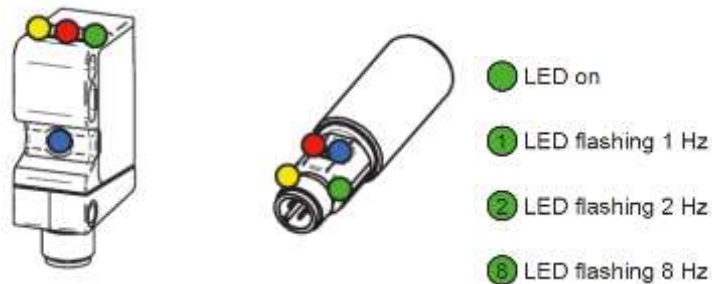

Figure 25: LED Indication U500, UR18

LED Indicators	Green	Yellow	Red	Blue
Power on	●			
Short circuit	①			
Output 1 active		●		
Output 1 signal close to threshold		⑧		
Output 2 active			●	
Output 2 signal close to threshold			⑧	
qTeach not locked				●

Figure 26: LED Indication - Standard-behavior in operating mode

Note: Only sensors with 2 digital outputs do have a red LED.

Parameter name	Short Description	Rights	Unit / Allowed values
LED Settings.Green.Mode	Switches the LED off, no change of other function	rw	On / Off Default: On
LED Settings.Yellow.Mode	Switches the LED off, no change of other function, or inverts the relationship between LED and pin Inverted:Pin high, LED off On: Pin high, LED on	rw	On / Off / Inverted Default: On
LED Settings.Red.Mode	Switches the LED off, no change of other function, or inverts the behaviour	rw	On / Off / Inverted Default: On

	between output switching behaviour and pin Inverted: Pin high, LED off On: Pin high, LED on		
LED Settings.Blue.Mode	Switches the LED off, no change of other function	rw	On / Off Default: On

If the LED mode is set

- *On*, the behaviour of the related LED is as described in Figure 26.
- *Off*, the LED is deactivated except if the function Find Me is activated. (See section 3.2.2)
- *Inverted*, the LED behaviour is inverted to the definition in Figure 26.

If the yellow LED is configured to work as alignment aid (only for the .R type), the LED indicates the strength of the received signal. The faster the flashing, the stronger the signal.

4.8.2 Teach Mode (Local, by wire)

For the local teach, 2 different teach methods are available – Xpert and Xpress.

While the Xpert mode represents the standard teach method with 4 teach levels available, the Xpress mode allows to simplify the teach-in procedure significantly by reducing it to only one teach level.

Also the number of actions required to teach-in the position is reduced to one single activation of qTeach or the ext. teach-in.

Parameter name	Short Description	Rights	Unit / Allowed values
Teach Mode Settings.Local Teach Mode	Selects the teach mode if more than one is available. Teach modes: 0: xPert: normal method, 1: xPress: simplified method	rw	xPert static, xPress static Default: xPert

4.8.2.1 xPert Mode

Available Teach Levels:

- Level 1: 1-Point Teach (Barriers: Including alignment aid)
- Level 2: Window Teach / Scanning Range
- Level 3: Output Logic of digital output 1 and output 2
- Level 4: Factory reset

For a more detailed description of the teach-in procedure, please refer to the assembly instruction.

4.8.2.2 Xpress Mode

Available Teach Levels:

- Level 1: Simplified 1-Point Teach

Teach-In Procedure:

- Place object at desired switching / reference distance
- Activate qTeach or ext. teach-in wire for >2 sec
 - o Green and blue LEDs flash 2 Hz
- Teach-In OK: Sensor goes into operating mode
- Teach-In NOK: All LEDs flash 8 Hz for 1 sec

See Figure 27 for a graphical illustration of the teach-in procedure by using qTeach.

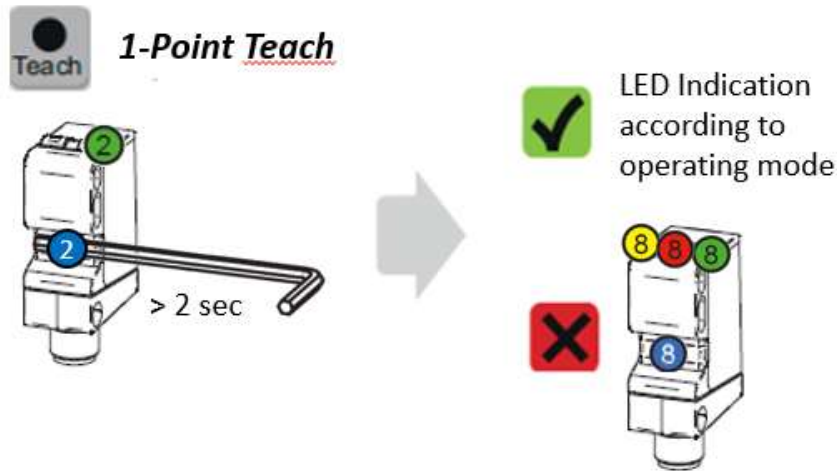

Figure 27: Teach-In procedure Xpress by using qTeach

4.8.3 qTeach Lock

By default the qTeach is locked 5 min after power up to avoid any undesirable manipulation. This lock timeout can be deactivated completely or adjusted from 1 ... 120 min. Only the qTeach is being affected. Teach-in by wire is always possible, it does not lock..

Parameter name	Short Description	Rights	Unit / Allowed values
Teach Lock Settings.qTeach Time Out	Time until qteach is locked. If 0 qteach never locks. If 0xFF qteach always off	rw	0: Never locked 1 ...120: locked after n minutes 0xFF: Always locked Default: 5 min

5 Teach Commands

By using teach commands, the setpoints of the switching signal channels SSC1 and SSC2 or of the Analog output can be defined by teach-in the position of the object or reference.

Next to teach-by-value which can be applied as described in section 4.3.1, using teach commands makes it easy to compensate individual variations such as mechanical and mounting tolerances.

The teach-in procedures are described more detailed in section 5.2 (Static).

The switching behavior of each switching signal channel depends on the configuration (Switching Mode, Channel Logic, ...) described in section 4.3.2.

5.1 Teach Channel Selection & Teach Status

The described teach commands can be applied to individual switching signal channels. Before proceeding with the teach-in procedure, make sure to select the SSC that should be addressed.

Furthermore different information are available to indicate the current mode and teach-in state of the selected switching signal channel to help to execute the right commands described in section 5.2 and 5.3.

Parameter name	Short Description	Rights	Unit / Allowed values
TI Select	Selection of the SSC for which the teach commands are valid (TI Select - Teach-In Select)	rw	Default (SSC1) / SSC1 / SSC2 Default: Default
TI Info.Mode of TI Select	Mode of the selected Teach channel	ro	Single Point / Window
TI Result. Teach Flag SP1	Shows the teach status of the respective switch point	ro	Not Taught / Taught
TI Result. Teach Flag SP2	Shows the teach status of the respective switch point	ro	Not Taught / Taught
TI Result.State	Shows the teach status of the teach-in process	ro	0 = Idle 1 = SP1 Success 2 = SP2 Success 3 = SP1&2 Success 4 = Waiting for Command 6 = Busy 7 = Error
Analog Output Teach.Status	Status of the Analog teach output	ro	x (Idle / Successful / Not Successful)

5.2 Static

By using teach commands, setpoint 1 and setpoint 2 (SP1 and SP2) can be set by placing the object at the desired position and triggering the command. Which command is used in which order varies depending on the active switching mode (Single-Point or Window) of the selected-teach channel and is explained below.

Parameter name	Short Description	Rights	Unit / Allowed values
System Command (Teach SP1)	Set SP1 at the current position of the object which is within the scanning range.	wo	
System Command (Teach SP2)	Set SP2 at the current position of the object which is within the scanning range.	wo	

System Command (Teach Apply)		WO	
System Command (Teach Cancel)		WO	

5.2.1 Single Point / 1-Point Teach

If the selected SSC is configured as Single Point mode (Changing the mode is explained in section 4.3.2.1), following command sequence is required to teach-in SP1:

Command sequence:

- Place object at desired switching distance
- Execute *Teach SP1* to teach-in the distance
- Execute *Teach Apply* to store the setpoint

By executing *Teach Cancel* the teach-in procedure can be canceled at any state, as long *Teach Apply* has not been used before.

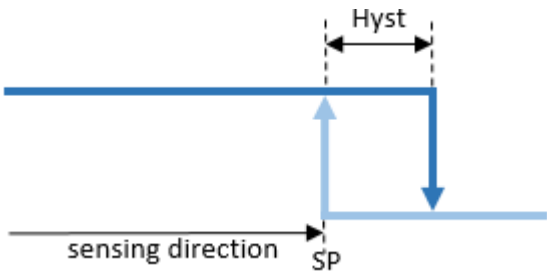
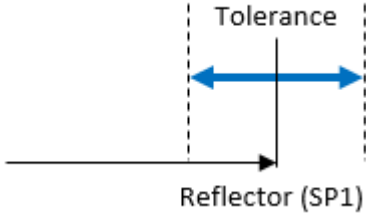
	
<p>Figure 28 Single Point Teach, switching behavior .P, .R, .D types</p> <p>In this example, the hysteresis is configured to be right aligned (See 4.3.2.4 for more details regarding hysteresis alignment)</p>	<p>Figure 29 Single Point Teach, switching behavior .R types</p> <p>For more detailed information about the reflector tolerance, see section 4.3.2.5.</p>

5.2.2 Window Teach

If the selected SSC is configured to Window mode (Changing the mode is explained in section 4.3.2.1), following command sequence can be applied to teach-in SP1 and SP2

Command sequence:

- Place object at desired switching distance
- Execute *Teach SP1* to teach-in the distance related to SP1
- Execute *Teach SP2* to teach-in the distance related to SP2
- Execute *Teach Apply* to store the setpoint

By executing *Teach Cancel* the teach-in procedure can be canceled at any state as long *Teach Apply* has not been used before.

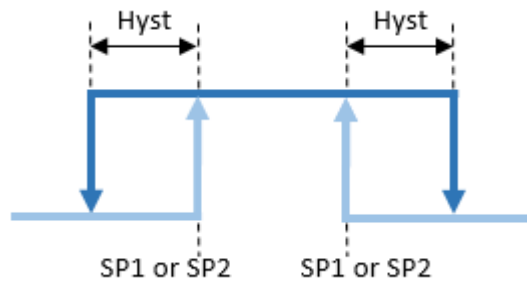

Figure 30: Window Teach, switching behavior

Figure 30 shows the switching behavior of the selected SSC if the teach-in was successful. In this example, the hysteresis is configured to be right aligned (See 4.3.2.4 for more details regarding hysteresis alignment)
 Which SP was taught at a higher distance does not have any influence on the switching behavior (SP1<SP2, SP1>SP2).

5.3 Static Analog out

For sensors with an analog output (.D types), the distance range mapped to the analog output range can be modified (reduced and/or inverted). Aside from the teach-by-value approach described in section 4.7.2.2, also a teach by command approach is possible.

Command sequence:

- Place object at the position which should be taught for the lower analog output value, position (A)
- Execute *Teach Analog Output Min*
- Place object at the position which should be taught for the upper analog output value, position (B)
- Execute *Teach Analog Output Max*
- Execute *Teach Apply* to store the value

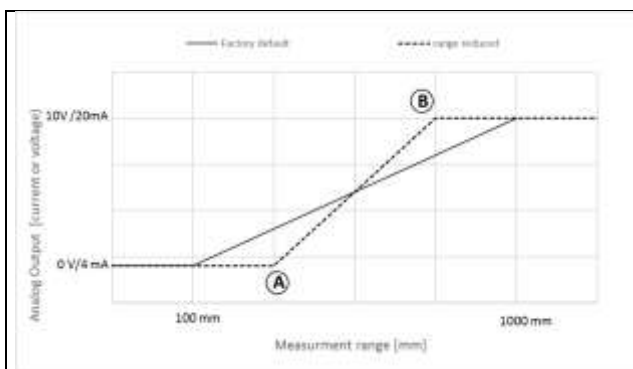

Figure 31 Reduced range of the analog output value for improved accuracy (analog value increased with distance)

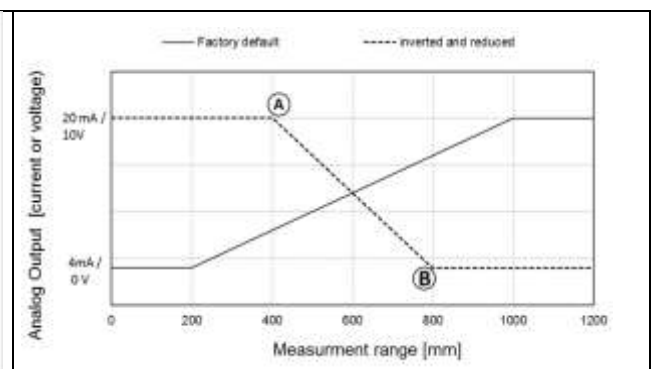

Figure 32 Reduced and inverted range of the analog output value for improved accuracy and different slope (analog value decreases with distance)

Parameter name	Short Description	Rights
Output Scale Distance at Analog Min	Teach-in the distance, mapped to the lower analog output value	wo
Output Scale Distance at Analog Max	Teach-in the distance, mapped to the upper analog output value	wo

6 Diagnosis

In addition to solving the primary application, the simple evaluation of secondary data, such as temperature, supply voltage or operating time, allows for predictive maintenance and thus optimum machine availability.

6.1 Device Status

Parameter name	Short Description	Rights	Unit / Allowed values
Device Status	Indicates if the sensor is working properly	ro	0=Device is OK 2=Out of Specification 4=Failure
Detailed Device Status		ro	

6.2 Device Temperature

An integrated temperature sensor allows to track the internal temperature of the sensor.

Please be aware that compared to the ambient temperature the indicated values are higher due to the internal heating of the sensor.

The temperature may also vary due to mounting conditions and due to the electric load connected to the output.

Parameter name	Short Description	Rights	Unit / Allowed values
Device Temperature Reset	Resets the device temperature statistic	wo	
Device Temperature.Current	Internal temperature of the sensor	ro	
Device Temperature.Resettable Min	Minimal measured internal temperature of the sensor (Resettable)	ro	
Device Temperature.Resettable Max	Maximal measured internal temperature of the sensor (Resettable)	ro	

Device Temperature.Lifetime Min	Minimal measured internal temperature of the sensor (Lifetime)	ro	
Device Temperature.Lifetime Max	Maximal measured internal temperature of the sensor (Lifetime)	ro	
Unit Selection.Temperature	Choice of temperature unit (Default: °C)	ro	°C, °F, K

6.3 Power Supply Voltage

Parameter name	Short Description	Rights	Unit / Allowed values
Power Supply Voltage Reset	Resets the device power supply [V] statistic	wo	
Power Supply Voltage.Current	Current power supply voltage	ro	V
Power Supply Voltage.Resettable Min	Minimal measured power supply voltage (Resettable by user command)	ro	V
Power Supply Voltage.Resettable Max	Maximal measured power supply voltage (Resettable by user command)	ro	V
Power Supply Voltage.Lifetime Min	Minimal measured power supply voltage over the complete lifetime	ro	V
Power Supply Voltage.Lifetime Max	Maximal measured power supply voltage over the complete lifetime	ro	V

6.4 Bootcycles

Parameter name	Short Description	Rights	Unit / Allowed values
Bootcycles.Lifetime	Total number of bootcycles over the complete lifetime	ro	Bootcycles

6.5 Operation Time

Parameter name	Short Description	Rights	Unit / Allowed values
Operation Time Reset	Resets the operation time statistic	wo	
Operation Time.Powerup	Operation time on power-up	ro	
Operation Time.Resettable	Operation time (Resettable by user command)	ro	
Operation Time.Lifetime	Lifetime operation time	ro	
Unit Selection.Time	Choice of time unit	ro	Second

6.6 Histogram

Several diagnosis and process values are continuously tracked to allow predictive maintenance or trouble shooting tasks. Instead of storing each value by itself, the values are stored in a histogram. Therefore the range of possible values is divided into several intervals (bins), then the number of occasions are counted that a new value falls into a interval (bin). This allows to store the values in a much more efficient way and ready for analysis.

Example based on Device Temperature:

- Range: -40 ... +120°C
- Number of Bins: 16 Bin
- Size of a Bin: $160^{\circ}\text{C} / 16 = 10^{\circ}\text{C}$
- Range of Bin 1: -40 ... -30.00 °C
- Range of Bin 2: -20.00 ... -10.00 °C
- ...
- Range of Bin 16: +110.00 °C ... +120 °C

By extracting the related bins and information via IO-Link, it is possible to plot a histogram to get easily the distribution of the values illustrated.

Such histograms are available for

- Device Temperature, Lifetime
- Power Supply Voltage, Lifetime
- Process Value 1: Distance, Resettable

Regarding Device Temperature and Power Supply Voltage, every 10 seconds a measurement is tracked. For the process values, every single measurement is tracked.

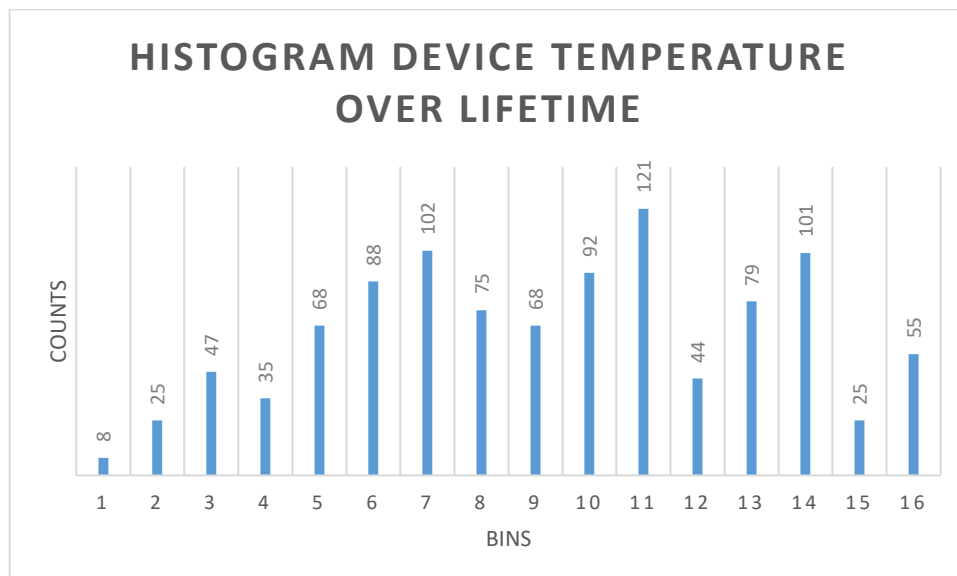

Figure 33: Histogram Device Temperature over Lifetime, Example

The counts of each bin are stored as 32 bit value (up to 4'294'967'296 counts).

6.6.1 Device Temperature

Parameter name	Short Description	Rights	Unit / Allowed values
Device Temperature Lifetime Histogram.Mode	Standard means: Linear partition of the range into bins.	ro	Standard
Device Temperature Lifetime Histogram Unit	Indicates the unit	ro	°C, K, F
Device Temperature Lifetime Histogram.RangeStart	Defines, where the range starts.	ro	-40
Device Temperature Lifetime Histogram.RangeEnd	Defines, where the range ends.	ro	+120
Device Temperature Lifetime Histogram.Nbr of Bins	Number of bins	ro	16
Device Temperature Lifetime Histogram Bin1 ... 16	Number of counts of each bin	ro	32 Bit for each bin

6.6.2 Power Supply

Parameter name	Short Description	Rights	Unit / Allowed values
Power Supply Voltage Lifetime Histogram.Mode	Standard means: Linear partition of the range into bins.	ro	Standard
Power Supply Voltage Lifetime Histogram.Unit	Indicates the unit	ro	Volts
Power Supply Voltage Lifetime Histogram.RangeStart	Defines, where the range starts.	ro	0
Power Supply Voltage Lifetime Histogram RangeEnd	Defines, where the range ends.	ro	+48
Power Supply Voltage Lifetime Histogram Nbr of Bins	Number of bins	ro	16
Power Supply Voltage Lifetime Histogram Bin1 ... 16	Number of counts of each bin	ro	32 Bit for each bin

6.6.3 Process Value 1: Distance

Parameter name	Short Description	Rights	Unit / Allowed values
Distance Resettable Histogramm Reset	Command to reset the histogram of process value 1	ro	
Distance Resettable Histogram.Mode	Standard means: Linear partition of the range into bins.	ro	Standard
Distance Resettable Histogram.Unit	Indicates the unit	ro	Millimeter
Distance Resettable Histogram.RangeStart	Defines, where the range starts.	ro	0
Distance Resettable Histogram.RangeEnd	Defines, where the range ends.	ro	1600
Distance Resettable Histogram.Nbr of Bins	Number of bins	ro	16
Distance Resettable Histogram.Bin1 ... 16	Number of counts of each bin	ro	32 Bit for each bin

7 Glossar

wo	Write only access
rw	Read and write access
ro	Read only access
SSC	Switching Signal Channel
MDC	Measurement Data Channel
SP	Switching Point

Baumer worldwide**Belgium**

Baumer SA/NV
BE-2260 Westerlo
Phone +32 14 57462 0

Brasil

Baumer do Brasil Ltda
BR-04726-001 São Paulo-
Capital
Phone +55 11 56410204

Canada

Baumer Inc.
CA-Burlington, ON L7M 4B9
Phone +1 (1)905 335-8444

China

Baumer (China) Co., Ltd.
CN-201612 Shanghai
Phone +86 (0)21 6768 7095

Denmark

Baumer A/S
DK-8210 Aarhus V.
Phone +45 (0)8931 7611

France

Baumer SAS
FR-74250 Fillinges
Phone +33 (0)450 392 466

Germany / Austria

Baumer GmbH
DE-61169 Friedberg
Phone +49 (0)6031 60 070

India

Baumer India Private Ltd.
IN-411038 Pune
Phone +91 (0)20 2528 6833

Italy

Baumer Italia S.r.l.
IT-20090 Assago, MI
Phone +39 (0)245 70 60 65

Poland

Baumer Sp.z.o.o.
PL-03-310 Warszawa
Phone +48 228321550

Republic of Korea

Baumer (Korea) Co., Ltd.
KR-411-766 Seoul
Phone +82-70-5055-0741 or
+82-31-995-6379

Singapore

Baumer (Singapore) Pte. Ltd.
SG-339412 Singapore
Phone +65 6396 4131

Spain

Baumer Automación Ibérica
S.L
ES-08021 Barcelona
Phone +34 932547864

Sweden

Baumer A/S
SE-56122 Huskvarna
Phone +46 (0)36 13 94 30

Switzerland (Headquarter)

Baumer Electric AG
CH-8501 Frauenfeld
Phone +41 (0)52 728 1122

United Arab Emirates

Baumer Middle East FZE
AE-0 Dubai
Phone +971 48876755

United Kingdom

Baumer Ltd.
GB-Watchfield, Swindon,
SN6 8TZ
Phone +44 (0)1793 783 839

USA

Baumer Ltd.
US-Southington , CT 06489
Phone +1 (1)860 621-2121

Venezuela

Baumer BAVE, AS
VE-1070 Caracas
Phone +58 2122569336

www.baumer.com/worldwide

Technical data has been fully checked, but accuracy of printed matter not guaranteed.