



Robert Bosch GmbH
Power Tools Division
70745 Leinfelden-Echterdingen

www.bosch-pt.com

1 619 929 797 (2007.12) T / 306

GBH 36 V-LI Compact Professional



de Originalbetriebsanleitung
en Original instructions
fr Notice originale
es Manual original
pt Manual original
it Istruzioni originali
nl Oorspronkelijke
gebruiksaanwijzing
da Original brugsanvisning
sv Bruksanvisning i original
no Original driftsinstruks
fi Alkuperäiset ohjeet

el Πρωτότυπο οδηγιών χρήσης
tr Orijinal işletme talimatı
pl Instrukcja oryginalna
cs Původním návodem k
používání
sk Pôvodný návod na použitie
hu Eredeti használati utasítás
ru Одинник руководства по
эксплуатации
uk Оригінальна інструкція з
експлуатації

ro Instrucțiuni de folosire
originale
bg Оригинално ръководство
за експлоатация
sr Originalno uputstvo za rad
sl Izvirna navodila
hr Originalne upute za rad
et Algupärane kasutusjuhend
lv Instrukcijām
oriģinālvalodā
lt Originali
instrukcija



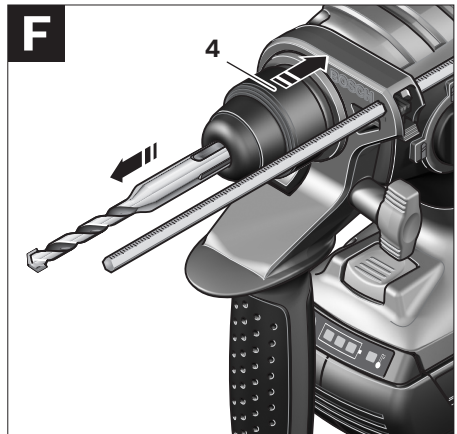
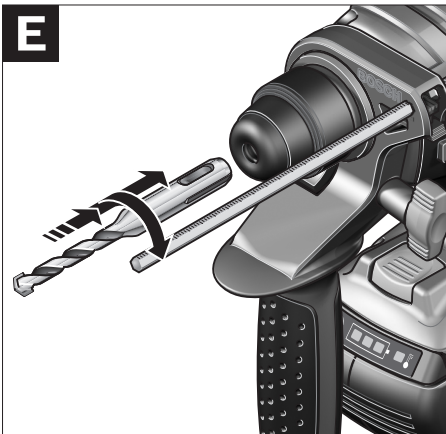
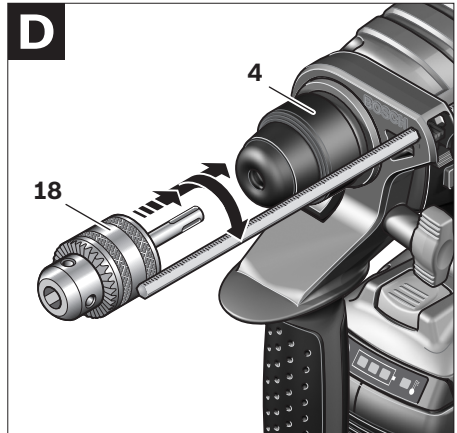
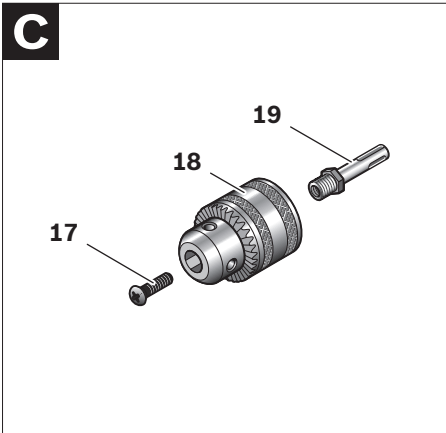
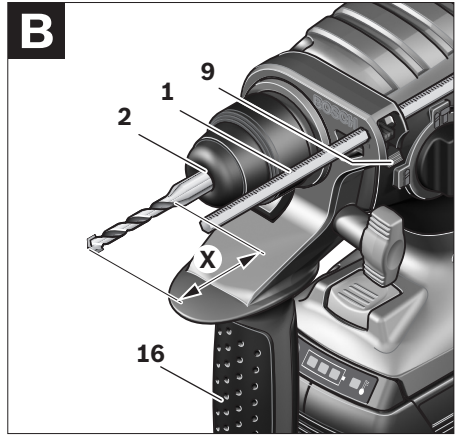
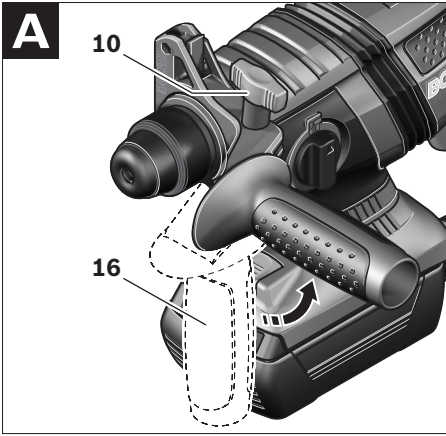

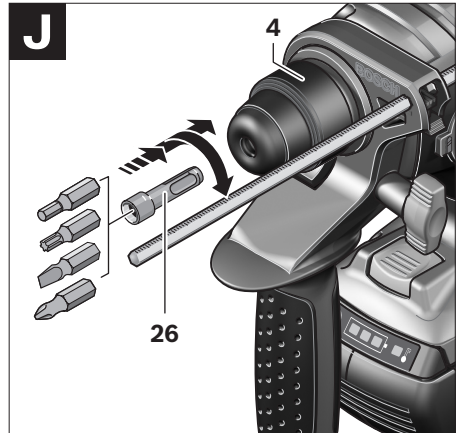
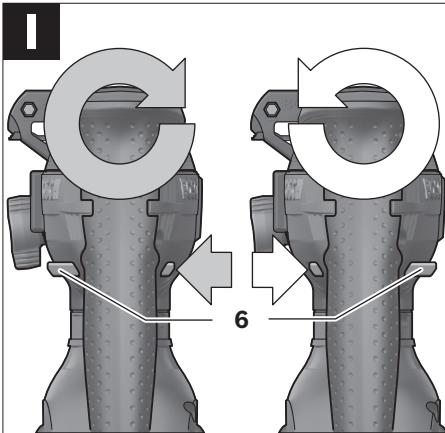
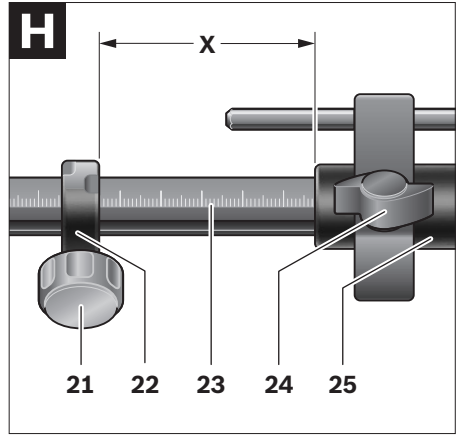
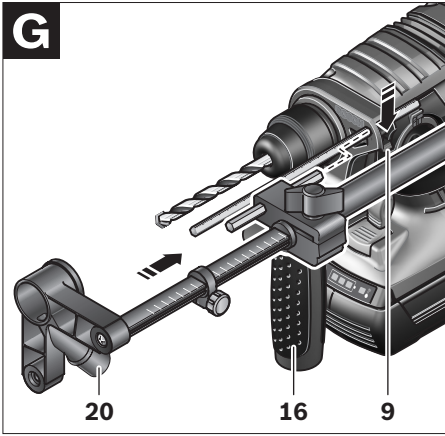

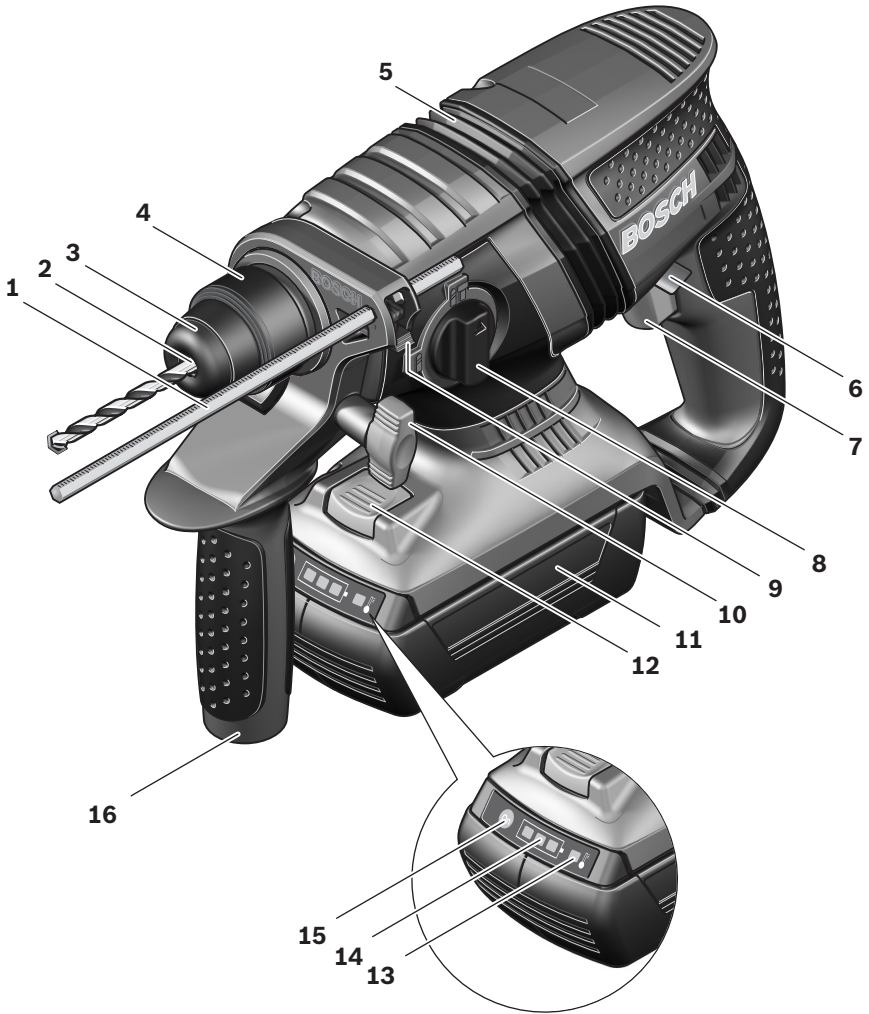

General Power Tool Safety Warnings

⚠ WARNING Read all safety warnings and all instructions. Failure to follow the warnings and instructions may result in electric shock, fire and/or serious injury.

Save all warnings and instructions for future reference.

The term “power tool” in the warnings refers to your mains-operated (corded) power tool or battery-operated (cordless) power tool.

1) Work area safety

- a) **Keep work area clean and well lit.**
Cluttered or dark areas invite accidents.
- b) **Do not operate power tools in explosive atmospheres, such as in the presence of flammable liquids, gases or dust.** Power tools create sparks which may ignite the dust or fumes.
- c) **Keep children and bystanders away while operating a power tool.** Distractions can cause you to lose control.

2) Electrical safety

- a) **Power tool plugs must match the outlet. Never modify the plug in any way. Do not use any adapter plugs with earthed (grounded) power tools.** Unmodified plugs and matching outlets will reduce risk of electric shock.
- b) **Avoid body contact with earthed or grounded surfaces, such as pipes, radiators, ranges and refrigerators.** There is an increased risk of electric shock if your body is earthed or grounded.
- c) **Do not expose power tools to rain or wet conditions.** Water entering a power tool will increase the risk of electric shock.
- d) **Do not abuse the cord. Never use the cord for carrying, pulling or unplugging the power tool. Keep cord away from heat, oil, sharp edges and moving parts.** Damaged or entangled cords increase the risk of electric shock.

e) **When operating a power tool outdoors, use an extension cord suitable for outdoor use.** Use of a cord suitable for outdoor use reduces the risk of electric shock.

f) **If operating a power tool in a damp location is unavoidable, use a residual current device (RCD) protected supply.** Use of an RCD reduces the risk of electric shock.

3) Personal safety

- a) **Stay alert, watch what you are doing and use common sense when operating a power tool. Do not use a power tool while you are tired or under the influence of drugs, alcohol or medication.**
A moment of inattention while operating power tools may result in serious personal injury.
- b) **Use personal protective equipment. Always wear eye protection.** Protective equipment such as dust mask, non-skid safety shoes, hard hat, or hearing protection used for appropriate conditions will reduce personal injuries.
- c) **Prevent unintentional starting. Ensure the switch is in the off-position before connecting to power source and/or battery pack, picking up or carrying the tool.** Carrying power tools with your finger on the switch or energising power tools that have the switch on invites accidents.
- d) **Remove any adjusting key or wrench before turning the power tool on.** A wrench or a key left attached to a rotating part of the power tool may result in personal injury.
- e) **Do not overreach. Keep proper footing and balance at all times.** This enables better control of the power tool in unexpected situations.
- f) **Dress properly. Do not wear loose clothing or jewellery. Keep your hair, clothing and gloves away from moving parts.** Loose clothes, jewellery or long hair can be caught in moving parts.

- g) If devices are provided for the connection of dust extraction and collection facilities, ensure these are connected and properly used. Use of dust collection can reduce dust-related hazards.
- 4) **Power tool use and care**
- a) **Do not force the power tool. Use the correct power tool for your application.** The correct power tool will do the job better and safer at the rate for which it was designed.
- b) **Do not use the power tool if the switch does not turn it on and off.** Any power tool that cannot be controlled with the switch is dangerous and must be repaired.
- c) **Disconnect the plug from the power source and/or the battery pack from the power tool before making any adjustments, changing accessories, or storing power tools.** Such preventive safety measures reduce the risk of starting the power tool accidentally.
- d) **Store idle power tools out of the reach of children and do not allow persons unfamiliar with the power tool or these instructions to operate the power tool.** Power tools are dangerous in the hands of untrained users.
- e) **Maintain power tools. Check for misalignment or binding of moving parts, breakage of parts and any other condition that may affect the power tool's operation. If damaged, have the power tool repaired before use.** Many accidents are caused by poorly maintained power tools.
- f) **Keep cutting tools sharp and clean.** Properly maintained cutting tools with sharp cutting edges are less likely to bind and are easier to control.
- g) **Use the power tool, accessories and tool bits etc. in accordance with these instructions, taking into account the working conditions and the work to be performed.** Use of the power tool for operations different from those intended could result in a hazardous situation.

5) Battery tool use and care

- a) **Recharge only with the charger specified by the manufacturer.** A charger that is suitable for one type of battery pack may create a risk of fire when used with another battery pack.
- b) **Use power tools only with specifically designated battery packs.** Use of any other battery packs may create a risk of injury and fire.
- c) **When battery pack is not in use, keep it away from other metal objects, like paper clips, coins, keys, nails, screws or other small metal objects, that can make a connection from one terminal to another.** Shorting the battery terminals together may cause burns or a fire.
- d) **Under abusive conditions, liquid may be ejected from the battery; avoid contact. If contact accidentally occurs, flush with water. If liquid contacts eyes, additionally seek medical help.** Liquid ejected from the battery may cause irritation or burns.

6) Service

- a) **Have your power tool serviced by a qualified repair person using only identical replacement parts.** This will ensure that the safety of the power tool is maintained.

Machine-specific Safety Warnings

- ▶ **Wear hearing protection.** Exposure to noise can cause hearing loss.
- ▶ **Always use the auxiliary handle supplied with the machine.** Loss of control can cause personal injury.
- ▶ **Use appropriate detectors to determine if utility lines are hidden in the work area or call the local utility company for assistance.** Contact with electric lines can lead to fire and electric shock. Damaging a gas line can lead to explosion. Penetrating a water line causes property damage or may cause an electric shock.

- ▶ **When working with the machine, always hold it firmly with both hands and provide for a secure stance.** The power tool is guided more secure with both hands.
- ▶ **Secure the workpiece.** A workpiece clamped with clamping devices or in a vice is held more secure than by hand.
- ▶ **Keep your workplace clean.** Blends of materials are particularly dangerous. Dust from light alloys can burn or explode.
- ▶ **Always wait until the machine has come to a complete stop before placing it down.** The tool insert can jam and lead to loss of control over the power tool.
- ▶ **Avoid unintentional switching on. Ensure the On/Off switch is in the off position before inserting battery pack.** Carrying the power tool with your finger on the On/Off switch or inserting the battery pack into power tools that have the switch on invites accidents.
- ▶ **Do not open the battery.** Danger of short-circuiting.



Protect the battery against heat, e.g., also against continuous sun irradiation and fire. There is danger of explosion.

- ▶ **In case of damage and improper use of the battery, vapours may be emitted. Provide for fresh air and seek medical help in case of complaints.** The vapours can irritate the respiratory system.
- ▶ **When the battery is defective, liquid can escape and come into contact with adjacent components. Check any parts concerned.** Clean such parts or replace them, if required.
- ▶ **Use the battery only in conjunction with your Bosch power tool.** This measure alone protects the battery against dangerous overload.

Functional Description



Read all safety warnings and all instructions. Failure to follow the warnings and instructions may result in electric shock, fire and/or serious injury.

While reading the operating instructions, unfold the graphics page for the machine and leave it open.

Intended Use

The machine is intended for hammer drilling in concrete, brick and stone. It is also suitable for drilling without impact in wood, metal, ceramic and plastic. Machines with electronic control and right/left rotation are also suitable for screwdriving.

Product Features

The numbering of the product features refers to the illustration of the machine on the graphics page.

- 1 Depth stop
- 2 SDS-plus tool holder
- 3 Dust protection cap
- 4 Locking sleeve
- 5 Vibration damper
- 6 Rotational direction switch
- 7 On/Off switch
- 8 Selector switch for drilling/hammer drilling
- 9 Button for depth stop adjustment
- 10 Wing bolt for adjustment of auxiliary handle
- 11 Battery*
- 12 Battery unlocking button
- 13 Temperature control indicator
- 14 Battery charge-control indicator
- 15 Button for charge-control indicator
- 16 Auxiliary handle
- 17 Securing screw for key type drill chuck*
- 18 Key type drill chuck*
- 19 SDS-plus adapter shank for drill chuck*
- 20 Extraction sleeve of the dust extraction attachment*
- 21 Clamping screw for the dust extraction attachment*
- 22 Depth stop of the dust extraction attachment*
- 23 Telescopic pipe of the dust extraction attachment*
- 24 Wing bolt of the dust extraction attachment*
- 25 Guide pipe of the dust extraction attachment*
- 26 Universal bit holder with SDS-plus shank*

***The accessories illustrated or described are not included as standard delivery.**

Technical Data

Rotary Hammer		GBH 36 V-Li Compact Professional
Article number		3 611 J03 R..
Speed control		●
Right/left rotation		●
Rated voltage	V=	36
Rated power input	W	430
Output power	W	320
Impact frequency at rated speed	bpm	0–4850
Impact energy per stroke	J	0–1.7
Rated speed	rpm	0–1500
Tool holder		SDS-plus
Spindle collar diameter	mm	48
Drilling diameter, max.:		
– Concrete	mm	18
– Steel	mm	13
– Wood	mm	30
max. diameter screw	mm	6
Weight according to EPTA-Procedure 01/2003	kg	2.9
Please observe the article number on the type plate of your machine. The trade names of the individual machines may vary.		

Noise/Vibration Information

Measured values determined according to EN 60745.

Typically the A-weighted noise levels of the product are: Sound pressure level 91 dB(A); Sound power level 102 dB(A). Uncertainty K=3 dB.

Wear hearing protection!

Vibration total values (triax vector sum) determined according to EN 60745:

Hammer drilling into concrete: Vibration emission value $a_{Hv} = 10 \text{ m/s}^2$, Uncertainty K=1.5 m/s^2 .

The vibration emission level given in this information sheet has been measured in accordance with a standardised test given in EN 60745 and may be used to compare one tool with another. It may be used for a preliminary assessment of exposure.

The declared vibration emission level represents the main applications of the tool. However if the tool is used for different applications, with different accessories or poorly maintained, the vibration emission may differ. This may significantly increase the exposure level over the total working period.

An estimation of the level of exposure to vibration should also take into account the times when the tool is switched off or when it is running but not actually doing the job. This may significantly reduce the exposure level over the total working period.

Identify additional safety measures to protect the operator from the effects of vibration such as: maintain the tool and the accessories, keep the hands warm, organisation of work patterns.

Declaration of Conformity

We declare under our sole responsibility that the product described under “Technical Data” is in conformity with the following standards or standardization documents: EN 60745 according to the provisions of the directives 2004/108/EC, 98/37/EC (until Dec. 28, 2009), 2006/42/EC (from Dec. 29, 2009 on).

Technical file at:

Robert Bosch GmbH, PT/ESC,
D-70745 Leinfelden-Echterdingen

Dr. Egbert Schneider Dr. Eckerhard Strötgen
Senior Vice President Head of Product
Engineering Certification

 i.v. Strötgen

09.10.2007, Robert Bosch GmbH, Power Tools Division
D-70745 Leinfelden-Echterdingen

Assembly

Battery Charging

► **Use only the battery chargers listed on the accessories page.** Only these battery chargers are matched to the lithium ion battery of your power tool.

Note: The battery is supplied partially charged. To ensure full capacity of the battery, completely charge the battery in the battery charger before using your power tool for the first time.

The lithium ion battery can be charged at any time without reducing its service life. Interrupting the charging procedure does not damage the battery.

The lithium ion battery is protected against deep discharging by the “Electronic Cell Protection (ECP)”. When the battery is empty, the machine is switched off by means of a protective circuit: The inserted tool no longer rotates.

⚠ WARNING **Do not continue to press the On/Off switch after the machine has been automatically switched off.** The battery can be damaged.

Removing the Battery

The battery **11** is equipped with two locking levels that should prevent the battery from falling out when pushing the battery unlocking button **12** unintentionally. As long as the battery is inserted in the power tool, it is held in position by means of a spring.

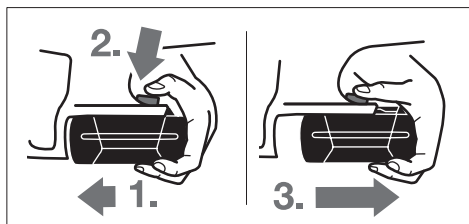

To remove the battery **11**:

- Push the battery against the base of the power tool (1.) and at the same time press the battery unlocking button **12** (2.).
- Pull the battery out of the power tool until a red stripe becomes visible (3.).
- Press the battery unlocking button **12** again and pull out the battery completely.

Battery Charge-control Indication

The three green LEDs of the battery charge-control indicator **14** indicate the charge condition of the battery **11**. For safety reasons, it is only possible to check the status of the charge condition when the machine is at a standstill.

Push button **15** to indicate the charge condition (also possible when the battery is removed).

The battery charge-control indicator automatically goes out after approx. 5 seconds.

LED	Capacity
Continuous lighting 3 x green	≥2/3
Continuous lighting 2 x green	≥1/3
Continuous lighting 1 x green	<1/3
Flashing light 1 x green	Reserve

When no LED lights up after pushing button **15**, then the battery is defective and must be replaced.

During the charging procedure, the three green LEDs light up one after the other and briefly go out. The battery is fully charged when the three green LEDs light up continuously. The three LEDs go out again approx. 5 minutes after the battery has been fully charged.

The battery is equipped with a NTC temperature control which allows charging only within a temperature range of between 0 °C and 45 °C. A long battery service life is achieved in this manner.

Auxiliary Handle

► **Operate your machine only with the auxiliary handle **16**.**

Rotating the Auxiliary Handle (see figure A)

The auxiliary handle **16** can be set to any position for a secure and low-fatigue working posture.

Turn the wing bolt for adjustment of the auxiliary handle **10** in anticlockwise direction and set the auxiliary handle **16** to the required position. Then tighten the wing bolt **10** again in clockwise direction.

Adjusting the Drilling Depth (see figure B)

The required drilling depth **X** can be set with the depth stop **1**.

Press the button for the depth stop adjustment **9** and insert the depth stop into the auxiliary handle **16**.

The knurled surface of the depth stop **1** must face downward.

Insert the SDS-plus drilling tool to the stop into the SDS-plus tool holder **2**. Otherwise, the availability of the SDS-plus drilling tool can lead to incorrect adjustment of the drilling depth.

Pull out the depth stop until the distance between the tip of the drill bit and the tip of the depth stop correspond with the desired drilling depth **X**.

Selecting Drill Chucks and Tools

For hammer drilling, SDS-plus tools are required that are inserted in the SDS-plus drill chuck.

For drilling without impact in wood, metal, ceramic and plastic as well as for screwdriving, tools without SDS-plus are used (e.g., drills with cylindrical shank). For these tools, a key-less chuck or a key type drill chuck are required.

Changing the Key Type Drill Chuck

To work with tools without SDS-plus (e.g., drills with cylindrical shank), a suitable drill chuck must be mounted (key type drill chuck or key-less chuck, accessories).

Mounting the Key Type Drill Chuck (see figure C)

Screw the SDS-plus adapter shank **19** into a key type drill chuck **18**. Secure the key type drill chuck **18** with the securing screw **17**. **Please observe that the securing screw has a left-hand thread.**

Inserting the Key Type Drill Chuck (see figure D)

Clean the shank end of the adapter shank and apply a light coat of grease.

Insert the key type drill chuck with the adapter shank into the tool holder with a turning motion until it automatically locks.

Check the locking effect by pulling the key type drill chuck.

Removing the Key Type Drill Chuck

Push the locking sleeve **4** toward the rear and pull out the key type drill chuck **18**.

Changing the Tool

The dust protection cap **3** largely prevents the entry of drilling dust into the tool holder during operation. When inserting the tool, take care that the dust protection cap **3** is not damaged.

► **A damaged dust protection cap should be changed immediately. We recommend having this carried out by an after-sales service.**

Inserting SDS-plus Drilling Tools (see figure E)

The SDS-plus drill chuck allows for simple and convenient changing of drilling tools without the use of additional tools.

Clean and lightly grease the shank end of the tool.

Insert the tool in a twisting manner into the tool holder until it latches itself.

Check the latching by pulling the tool.

As a requirement of the system, the SDS-plus drilling tool can move freely. This causes a certain radial run-out at no-load, which has no effect on the accuracy of the drill hole, as the drill bit centres itself upon drilling.

Removing SDS-plus Drilling Tools (see figure F)

Push back the locking sleeve **4** and remove the tool.

Inserting Drilling Tools without SDS-plus

Note: Do not use tools without SDS-plus for hammer drilling! Tools without SDS-plus and their drill chucks are damaged by hammer drilling.

Insert a key type drill chuck **18** (see “Changing the Key Type Drill Chuck”, page 22).

Open the key type drill chuck **18** by turning until the tool can be inserted. Insert the tool.

Insert the chuck key into the corresponding holes of the key type drill chuck **18** and clamp the tool uniformly.

Set the selector switch **8** to the “Drilling” symbol.

Removing Drilling Tools without SDS-plus

Turn the sleeve of the key type drill chuck **18** with the drill chuck key in anticlockwise direction until the drilling tool can be removed.

Dust Extraction with the Dust Extraction Attachment (Accessory)

- ▶ Dusts from materials such as lead-containing coatings, some wood types, minerals and metal can be harmful to one's health. Touching or breathing-in the dusts can cause allergic reactions and/or lead to respiratory infections of the user or bystanders. Certain dusts, such as oak or beech dust, are considered as carcinogenic, especially in connection with wood-treatment additives (chromate, wood preservative). Materials containing asbestos may only be worked by specialists.
 - Use dust extraction whenever possible.
 - Provide for good ventilation of the working place.
 - It is recommended to wear a P2 filter-class respirator.

Observe the relevant regulations in your country for the materials to be worked.

Mounting the Dust Extraction Attachment (see figure G)

For dust extraction, the dust extraction attachment (accessory) is required. When drilling, the dust extraction attachment retracts so that the attachment head is always close to the surface at the drill hole.

Press the button for depth stop adjustment **9** and remove the depth stop **1**. Press button **9** again and insert the dust extraction attachment into the auxiliary handle **16** from the front.

Connect an extraction hose (diameter 19 mm, accessory) to the extraction sleeve **20** of the dust extraction attachment.

The vacuum cleaner must be suitable for the material being worked.

When vacuuming dry dust that is especially detrimental to health or carcinogenic, use a special vacuum cleaner.

Adjusting the Drilling Depth on the Dust Extraction Attachment (see figure H)

The required drilling depth **X** can also be adjusted when the dust extraction attachment is mounted.

Insert the SDS-plus drilling tool to the stop into the SDS-plus tool holder **2**. Otherwise, the movability of the SDS-plus drilling tool can lead to incorrect adjustment of the drilling depth.

Loosen the wing bolt **24** on the dust extraction attachment.

Without switching the power tool on, apply it firmly to the drilling location. The SDS-plus drilling tool must face against the surface.

Position the the guide pipe **25** of the dust extraction attachment in its holding fixture in such a manner that the head of the dust extraction attachment faces against the surface to be drilled. Do not slide the guide pipe **25** further over the telescopic pipe **23** of the dust extraction attachment than required, so that as much as possible of the scale **23** on the telescopic pipe remains visible.

Retighten the wing bolt **24** again. Loosen the clamping screw **21** on the depth stop of the dust extraction attachment.

Move the depth stop **22** on the telescopic pipe **23** in such a manner that the clearance **X** shown in the figure corresponds with the required drilling depth.

Tighten the clamping screw **21** in this position.

Operation

Starting Operation

Inserting the Battery

- ▶ **Use only original Bosch lithium ion batteries with the voltage listed on the nameplate of your power tool.** Using other batteries can lead to injuries and pose a fire hazard.

Set the rotational direction switch **6** to the centre position to protect the power tool against accidental starting.

Insert the charged battery **11** from the front into the base of the power tool. Push the battery completely into the base until the red stripe can no longer be seen and the battery is securely locked.

Setting the Operating Mode

With the selector switch for drilling/hammer drilling **8**, the operating mode of the machine is selected.

Note: Change the operating mode only when the machine is switched off! Otherwise, the machine can be damaged.

To change the operating mode, turn the selector switch for “drilling/hammer drilling” **8** to the requested position.

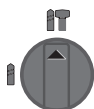

Position for **hammer drilling** in concrete or stone

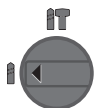

Position for **drilling** without impact in wood, metal, ceramic and plastic as well as for screwdriving

Reversing the Rotational Direction (see figure 1)

The rotational direction switch **6** is used to reverse the rotational direction of the machine. However, this is not possible with the On/Off switch **7** actuated.

↻ **Right rotation:** Push the rotational direction switch **6** left to the stop.

↻ **Left rotation:** Push the rotational direction switch **6** right to the stop.

For hammer drilling and drilling, always set the direction of rotation to right rotation.

Switching On and Off

To **start** the machine, press the On/Off switch **7**. When starting the machine for the first time, a starting delay is possible, as the electronic system of the power tool has to configure itself first. To **switch off** the machine, release the On/Off switch **7**.

Setting the Speed/Impact Rate

The speed/impact rate of the switched on power tool can be variably adjusted, depending on how far the On/Off switch **7** is pressed.

Light pressure on the On/Off switch **7** results in low speed/impact rate. Further pressure on the switch increases the speed/impact rate.

Safety Clutch

- ▶ **If the tool insert becomes caught or jammed, the drive to the drill spindle is interrupted. Because of the forces that occur, always hold the power tool firmly with both hands and provide for a secure stance.**
- ▶ **If the power tool jams, switch the machine off and loosen the tool insert. When switching the machine on with the drilling tool jammed, high reaction torques can occur.**

Temperature Control Indicator

The red LED of the temperature control indicator **13** signals that the battery or the electronics of the power tool (when the battery is inserted) are not within the optimum temperature range. In this case, the power tool will not operate at full capacity.

Temperature control of the battery:

- The red LED **13** lights up continuously after inserting the battery into the charger: The battery is not within the charging temperature range between 0 °C and 45 °C and cannot be charged.
- The red LED **13** flashes when pushing button **15** or pressing the On/Off switch **7** (when the battery is inserted): The battery is not within the temperature range for operation of -10 °C to +60 °C.
- For battery temperatures over 70 °C, the power tool switches off until the battery is in the optimal temperature range again.

Temperature control of the power tool electronics:

- The red LED **13** lights up continuously when pressing the On/Off switch **7**: The temperature of the machine's electronics is below 5 °C or above 75 °C.
- At a temperature above 90 °C, the electronics of the power tool switch off until the temperature is within the allowable temperature range again.

Working Advice

Vibration Damper



The integrated vibration damper reduces occurring vibrations.

The soft grip handle increases the safety against slipping off and thus provides for a better grip and handling of the power tool.

Inserting Screwdriver Bits (see figure J)

- ▶ **Apply the power tool to the screw/nut only when it is switched off.** Rotating tool inserts can slip off.

To work with screwdriver bits, a universal bit holder **26** with SDS-plus shank (accessory) is required.

Clean the shank end of the adapter shank and apply a light coat of grease.

Insert the universal bit holder with a turning motion into the tool holder until it automatically locks.

Check the locking effect by pulling the universal bit holder.

Insert a screwdriver bit into the universal bit holder. Use only screwdriver bits that match the screw head.

To remove the universal bit holder, pull the locking sleeve **4** toward the rear and remove the universal bit holder **26** out of the tool holder.

Recommendations for Optimal Handling of the Battery

Protect the battery against moisture and water.

Store the battery only within a temperature range between 0 °C and 45 °C. As an example, do not leave the battery in the car in summer.

Occasionally clean the venting slots of the battery using a soft, clean and dry brush.

A significantly reduced working period after charging indicates that the battery is used and must be replaced.

Observe the notes for disposal.

Maintenance and Service

Maintenance and Cleaning

- ▶ **Before any work on the machine itself (e.g. maintenance, tool change, etc.) as well as during transport and storage, remove the battery from the power tool.** There is danger of injury when unintentionally actuating the On/Off switch.
- ▶ **For safe and proper working, always keep the machine and ventilation slots clean.**
- ▶ **A damaged dust protection cap should be changed immediately. We recommend having this carried out by an after-sales service.**

Clean the tool holder **2** each time after using.

If the machine should fail despite the care taken in manufacturing and testing procedures, repair should be carried out by an after-sales service centre for Bosch power tools.

In all correspondence and spare parts order, please always include the 10-digit article number given on the type plate of the machine.

Spare Parts

Auxiliary handle

(without depth stop) 1 612 025 078

After-sales service and customer assistance

Our after-sales service responds to your questions concerning maintenance and repair of your product as well as spare parts. Exploded views and information on spare parts can also be found under: **www.bosch-pt.com**

Our customer consultants answer your questions concerning best buy, application and adjustment of products and accessories.

Great Britain

Robert Bosch Ltd. (B.S.C.)

P.O. Box 98

Broadwater Park

North Orbital Road

Denham

Uxbridge

UB 9 5HJ

Tel. Service: +44 (0844) 736 0109

Fax: +44 (0844) 736 0146

E-Mail: SPT-Technical.de@de.bosch.com

Ireland

Origo Ltd.

Unit 23 Magna Drive
Magna Business Park
City West
Dublin 24

Tel. Service: +353 (01) 4 66 67 00

Fax: +353 (01) 4 66 68 88

Australia, New Zealand and Pacific Islands

Robert Bosch Australia Pty. Ltd.

Power Tools

Locked Bag 66

Clayton South VIC 3169

Customer Contact Center

Inside Australia:

Phone: +61 (01300) 307 044

Fax: + 61 (01300) 307 045

Inside New Zealand:

Phone: +64 (0800) 543 353

Fax: +64 (0800) 428 570

Outside AU and NZ:

Phone: +61 (03) 9541 5555

www.bosch.com.au

Transport

The battery is tested according to UN document ST/SG/AC.10/11/Rev.3 Part III, subsection 38.3. It has effective protection against internal over-pressure and short circuiting as well as devices for the prevention of violent rupture and dangerous reverse current flow.

The lithium-equivalent content in the battery is below applicable limit values. Therefore, the battery is not subject to national or international regulations pertaining to dangerous mediums, neither as an individual component nor when inserted into a machine. However, the regulations governing dangerous goods may be relevant when transporting several batteries. In this case, it can be necessary to comply with special conditions (e.g., concerning the packaging). For more information, please refer to the instruction sheet (in English) under the following Internet address: <http://purchasing.bosch.com/en/start/Allgemeines/Download/index.htm>.

Disposal

The machine, accessories and packaging should be sorted for environmental-friendly recycling.

Only for EC countries:



Do not dispose of power tools into household waste!

According to the European Guideline 2002/96/EC for Waste Electrical and Electronic Equipment and its implementation into national

right, power tools that are no longer usable must be collected separately and disposed of in an environmentally correct manner.

Battery packs/batteries:

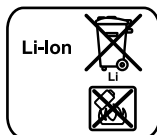

Li-ion:

Please observe the instructions in section "Transport", page 26.

Do not dispose of battery packs/batteries into household waste, fire or water. Battery packs/batteries should be collected, recycled or disposed of in an environmental-friendly manner.

Only for EC countries:

Defective or dead out battery packs/batteries must be recycled according to the guideline 91/157/EEC.

Batteries no longer suitable for use can be directly returned at:

Great Britain

Robert Bosch Ltd. (B.S.C.)

P.O. Box 98

Broadwater Park

North Orbital Road

Denham

Uxbridge

UB 9 5HJ

Tel. Service: +44 (0844) 736 0109

Fax: +44 (0844) 736 0146

E-Mail: SPT-Technical.de@de.bosch.com

Subject to change without notice.