

CHARX T1HCI12-1AC48-2,0M1 - Vehicle charging inlet



1271960

<https://www.phoenixcontact.com/pc/products/1271960>

Please be informed that the data shown in this PDF document is generated from our online catalog. Please find the complete data in the user documentation. Our general terms of use for downloads are valid.



CHARX connect universal, Vehicle charging inlet, for charging electric vehicles with alternating current (AC), AC type 1, IEC 62196-2, SAE J1772, 48 A / 250 V (AC), Single wires, length: 2 m, locking actuator: 12 V, 4-pos., Front and rear mounting, M6, housing: black, A protective cap is supplied as standard for the AC contacts.

Product description

Vehicle charging inlet for charging with alternating current (AC), compatible with type 1 AC vehicle charging connectors (EVSE), for installation in electric vehicles (EV).

Your advantages

- Complete product range
- Uniform, space-saving dimensions for the installation space and the screw connection points of all Phoenix Contact vehicle charging inlets
- Developed and produced in accordance with the IATF 16949 automotive standard and ISO 9001
- Integrated interlock during charging
- Manual emergency release of the locking actuator
- Protected and sealed against dirt and water with a high degree of protection

Commercial data

Item number	1271960
Packing unit	1 pc
Minimum order quantity	1 pc
Product key	XWCAIA
GTIN	4063151463229
Weight per piece (including packing)	1,405.2 g
Weight per piece (excluding packing)	1,400.2 g
Customs tariff number	85444290
Country of origin	PL

CHARX T1HCI12-1AC48-2,0M1 - Vehicle charging inlet



1271960

<https://www.phoenixcontact.com/pc/products/1271960>

Technical data

Notes

General	A protective cap is supplied as standard for the AC contacts.
---------	---

Product properties

Product type	Vehicle charging inlet
Product family	CHARX connect universal
Application	for charging electric vehicles with alternating current (AC) for installation in electric vehicles (EV)
Charging standard	AC type 1
Charging mode	Mode 2, 3

Electrical properties

Type of signal transmission	Pulse width modulation with modulated Powerline communication in accordance with ISO/IEC 15118 / DIN SPEC 70121
Note on the connection method	Crimp connection, cannot be disconnected
Insulation resistance	> 200 M Ω
Coding	2.7 k Ω (between PE and CS)
Temperature monitoring	AC contacts: PTC chain (DIN EN 60738-1)
Type of charging current	AC single-phase
Charging power	12 kW
Charging current	48 A

Power contact

Number	3 (L1, N, PE)
Rated voltage	250 V AC
Rated current	48 A AC

Signal contact

Number	2 (CP, CS)
Rated voltage	30 V AC
Rated current	2 A

Temperature sensors (PTC chain)

Sensor type	PTC chain
Standards/regulations	DIN EN 60738-1
Attachment point	Sensor for the AC contacts
Measuring range_resistance	790.00 Ω ... 1420.00 Ω
Resistance	max. 1200 Ω \pm 5 K
Recommended measured current	\leq 1 mA (U_{max} = 16 V DC)
Ambient temperature	-40 $^{\circ}$ C ... 130 $^{\circ}$ C (Operation)

Locking actuator

Operating voltage	12 V
-------------------	------

CHARX T1HCI12-1AC48-2,0M1 - Vehicle charging inlet



1271960

<https://www.phoenixcontact.com/pc/products/1271960>

Note number of positions	4-pos.
Position of the locking actuator	top center

Locking actuator

Operating voltage	12 V
Note number of positions	4-pos.
Position of the locking actuator	top center
Possible power supply range at the motor	9 V ... 16 V
Maximum voltage for locking detection	12 V
Typical motor current for locking	0.25 A
Reverse current of the motor	max. 1.5 A
Max. dwell time with reverse current	1 s
Recommended adaptation time	600 ms
Pause time after entry or exit path	3 s
Service life insertion cycles	> 10000 load cycles
Lock recognition	available
Mechanical emergency release	available
Ambient temperature (operation)	-40 °C ... 80 °C

Dimensions

Width	73 mm
Height	73 mm
Depth	73 mm

Material specifications

Color (Housing)	black (9005)
Color (Mating face)	black (9005)
Material (Housing)	Plastic
Material (Contact surface)	Silver

Cable/line

Cable length	2 m
Cable type	Single wires

Single-core wires for AC

Cable length	2 m
Cable structure	3 x 6 mm ²
Single wire, material	Silicone
Single wire, color	OG
External cable diameter	13.80 mm ±0.3 mm
Cable resistance	≤ 3.2 Ω/km

Single-core wires for locking actuator

Cable length	1.5 m
Cable structure	4 x 0.5 mm ²
Single wire, material	PVC

CHARX T1HCI12-1AC48-2,0M1 - Vehicle charging inlet



1271960

<https://www.phoenixcontact.com/pc/products/1271960>

Single wire, color	BU/RD, BU/GN, BU/YE, BU/BN
External cable diameter	1.60 mm ±0.20 mm
Cable resistance	≤ 37.1 Ω/m

Single-core wires for temperature sensors

Cable length	1 m
Cable structure	5 x 0,5 mm ²
Single wire, color	BN/GY BN/YE/GN
External cable diameter	1.60 mm ±0.20 mm
Cable resistance	≤ 37.1 Ω/m

Single-core wires for communication

Cable length	1 m
Cable structure	2 x 0.5 mm ²
Single wire, material	PVC
Single wire, color	BK WH
External cable diameter	1.60 mm ±0.20 mm
Cable resistance	≤ 37.1 Ω/m

Mechanical properties

Mechanical data

Insertion/withdrawal cycles	> 10000
Insertion force	< 75 N
Withdrawal force	< 75 N

Environmental and real-life conditions

Ambient conditions

Degree of protection (Vehicle charging inlet)	IP55 (plugged in; when plugged in and ready to operate, the degree of protection is only ensued if both plug-in components are original products from Phoenix Contact or suitable standard-compliant products) IP67 (Inner area of vehicle charging inlet)
Ambient temperature (operation)	-40 °C ... 60 °C
Ambient temperature (storage/transport)	-40 °C ... 85 °C
Altitude	4000 m (above sea level)

Standards and regulations

Standards

Standards/regulations	IEC 62196-2 SAE J1772
-----------------------	--------------------------

Mounting

Mounting type	Front and rear mounting (0 to 90 degree frontal inclination)
---------------	--

CHARX T1HCI12-1AC48-2,0M1 - Vehicle charging inlet



1271960

<https://www.phoenixcontact.com/pc/products/1271960>

	possible)
Mounting hole diameter	6.70 mm (ø)
Fixing screws	M6
Screws included in the scope of delivery	none

CHARX T1HCI12-1AC48-2,0M1 - Vehicle charging inlet

1271960

<https://www.phoenixcontact.com/pc/products/1271960>

Drawings

Dimensional drawing

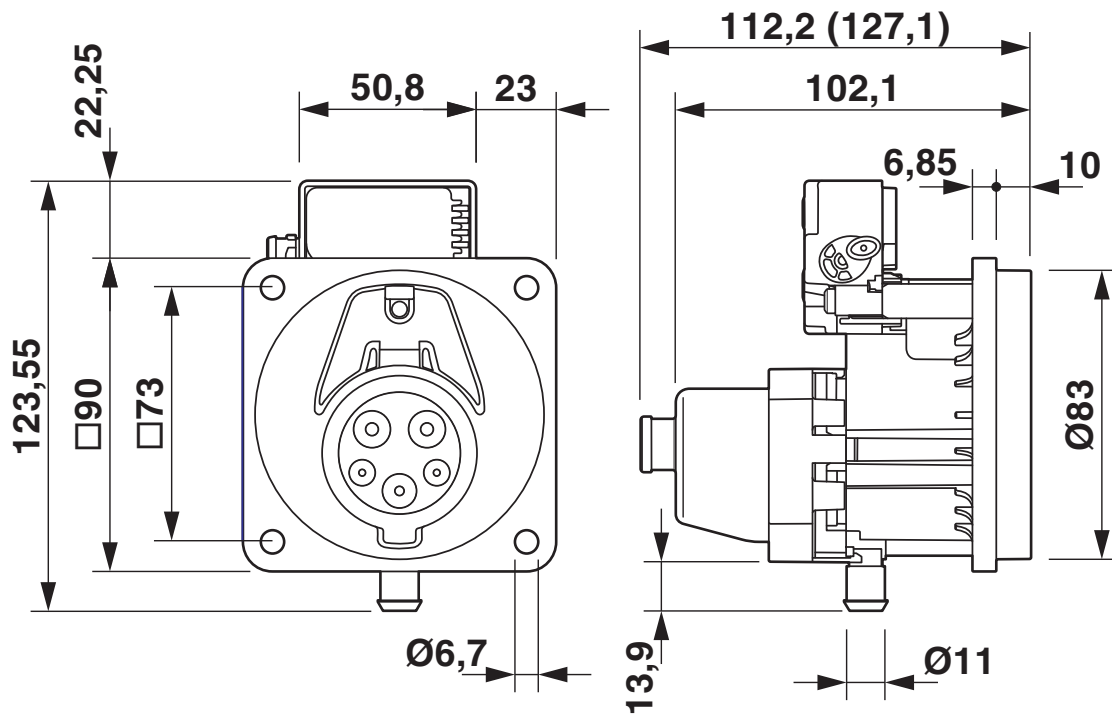

Dimensional drawing

Connection diagram

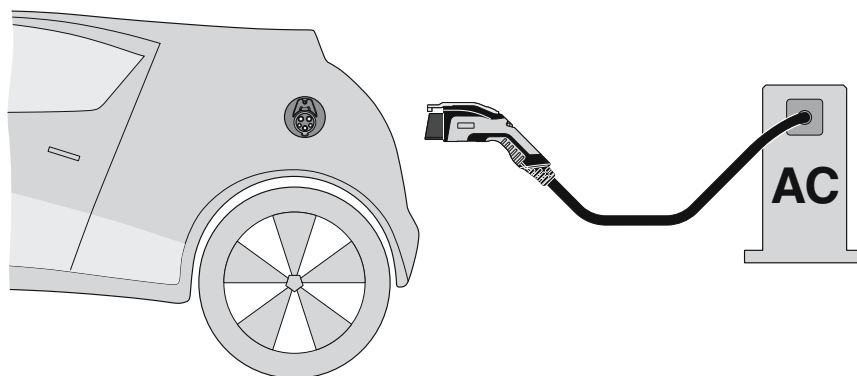

Terminology definition

CHARX T1HCI12-1AC48-2,0M1 - Vehicle charging inlet

1271960

<https://www.phoenixcontact.com/pc/products/1271960>

Schematic diagram

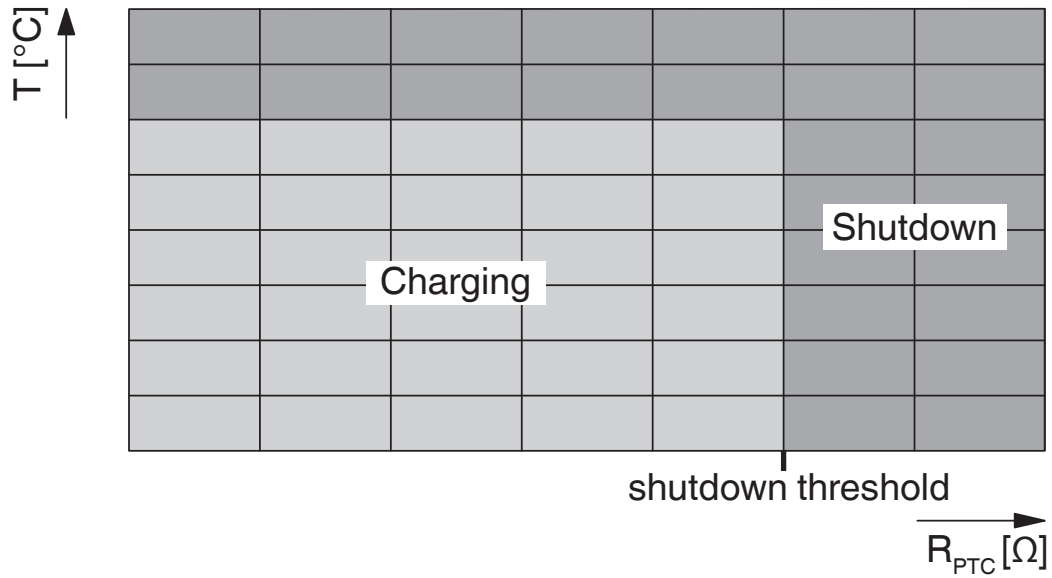

Temperature sensor technology resistance range at AC contacts

Connection diagram

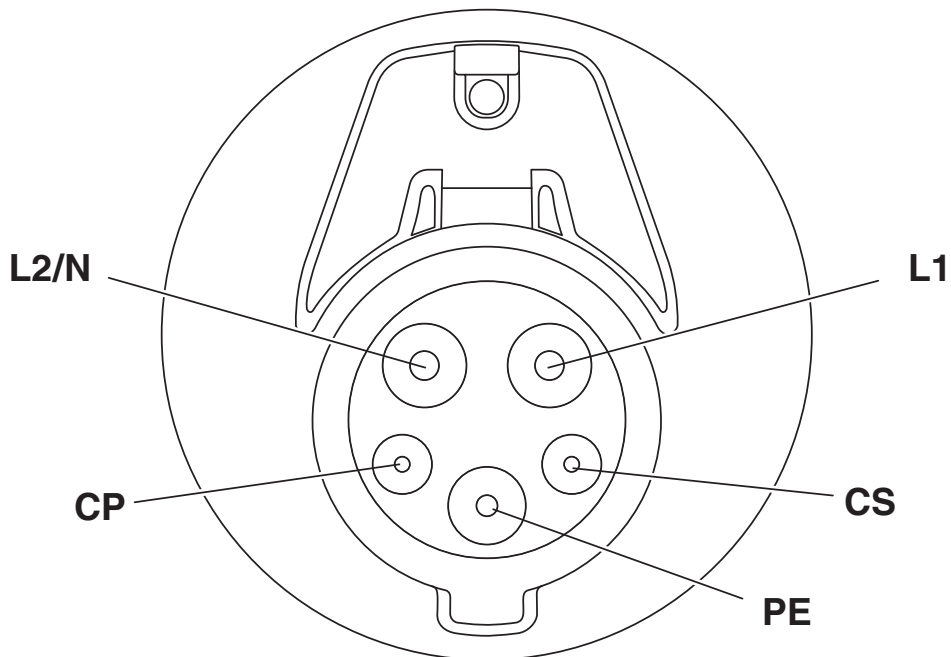

Pin assignment of vehicle charging inlets

CHARX T1HCI12-1AC48-2,0M1 - Vehicle charging inlet

1271960

<https://www.phoenixcontact.com/pc/products/1271960>

Functional drawing

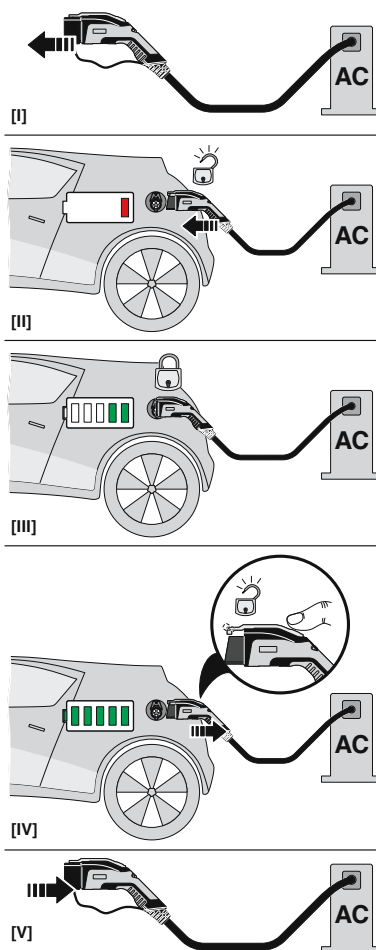

Operating instructions

CHARX T1HCI12-1AC48-2,0M1 - Vehicle charging inlet

1271960

<https://www.phoenixcontact.com/pc/products/1271960>

Schematic diagram

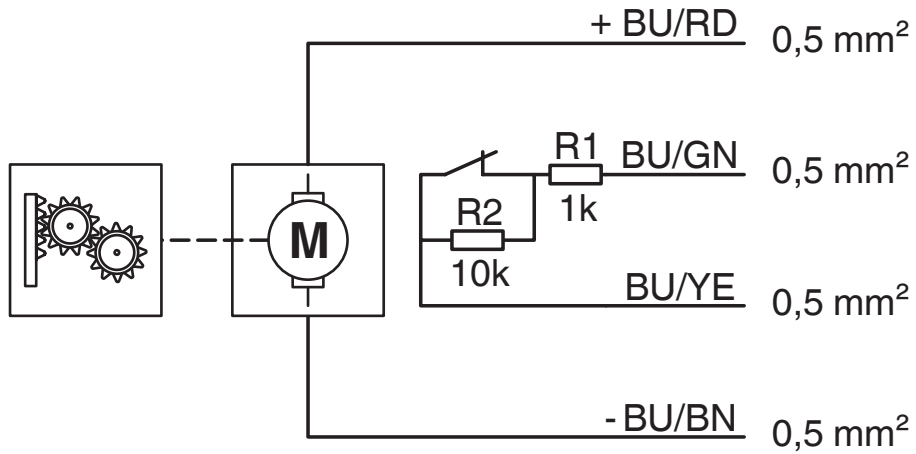

Block diagram of the locking actuator

CHARX T1HCI12-1AC48-2,0M1 - Vehicle charging inlet

1271960

<https://www.phoenixcontact.com/pc/products/1271960>

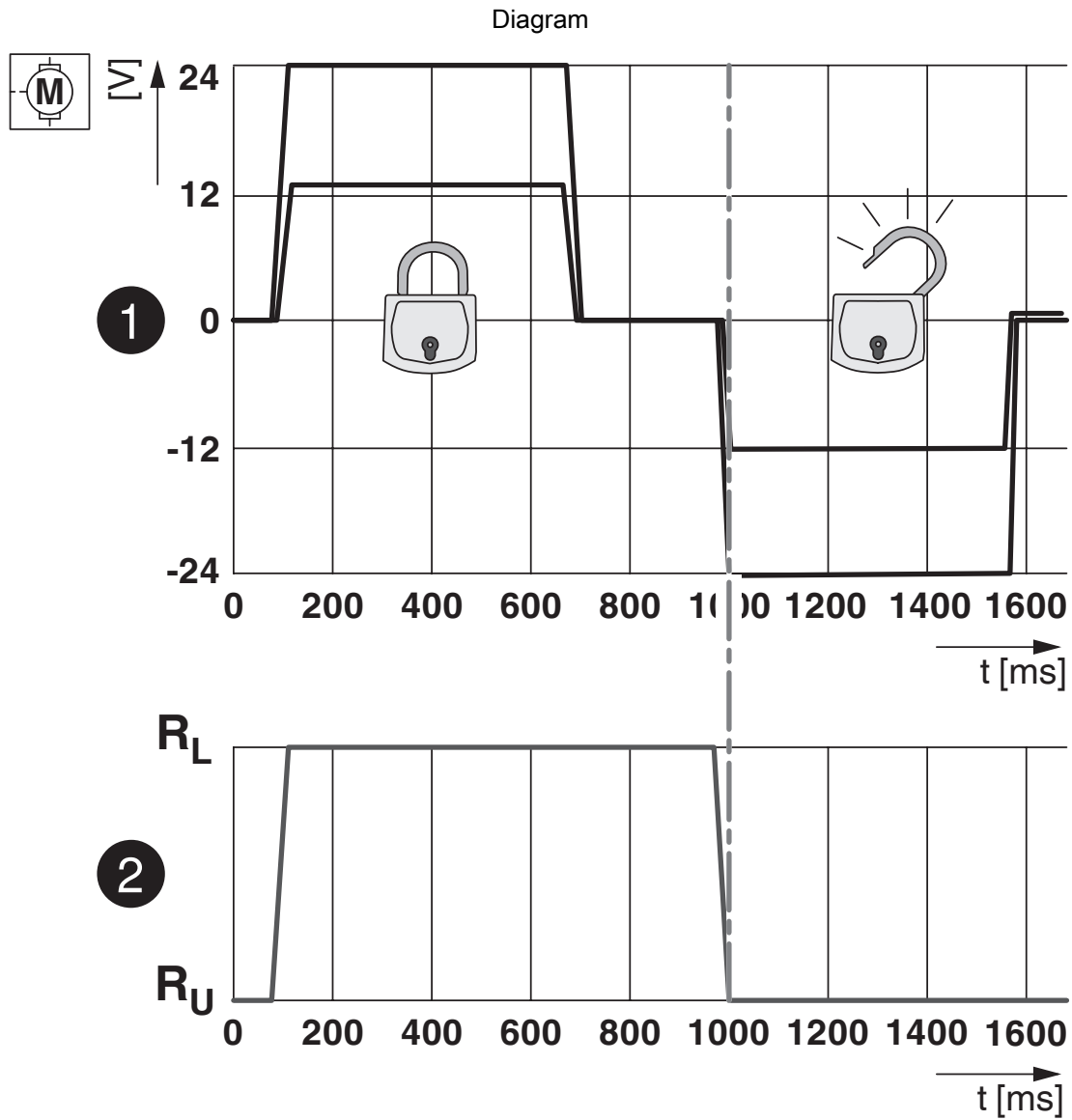

Locking states of the locking actuator

CHARX T1HCI12-1AC48-2,0M1 - Vehicle charging inlet

1271960

<https://www.phoenixcontact.com/pc/products/1271960>

Schematic diagram

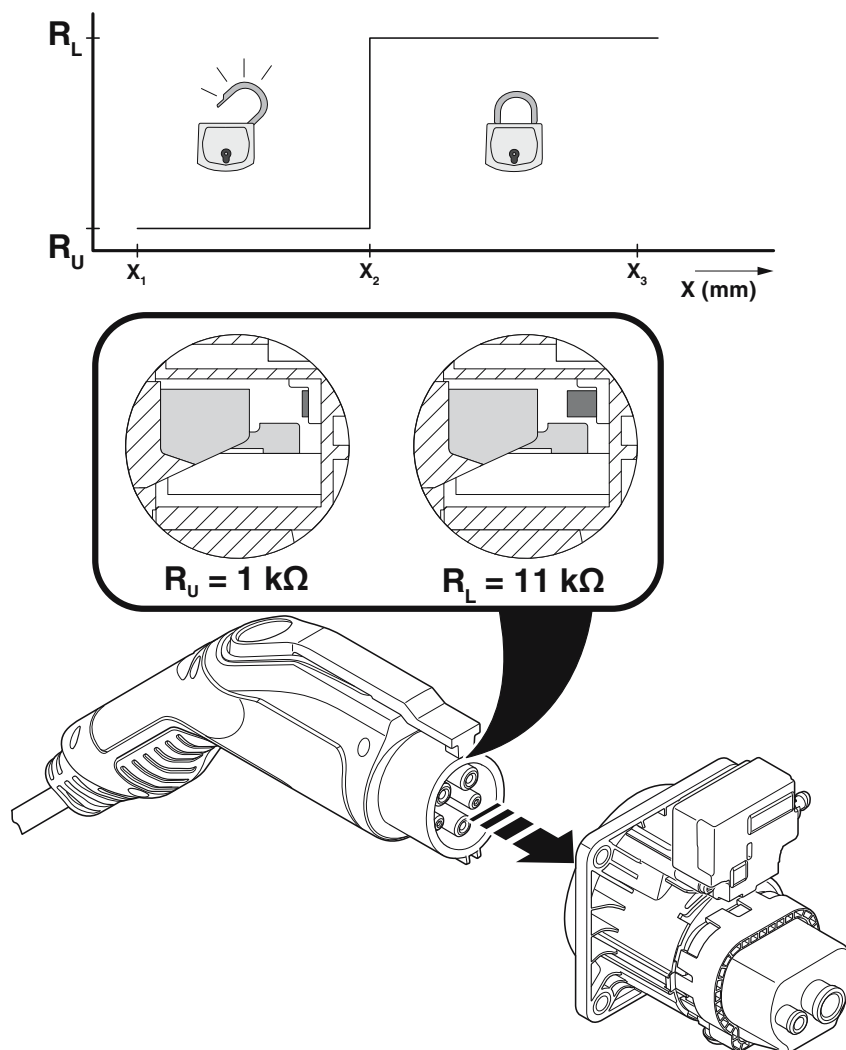

Detection for Vehicle Connector

CHARX T1HCI12-1AC48-2,0M1 - Vehicle charging inlet



1271960

<https://www.phoenixcontact.com/pc/products/1271960>

Connection diagram

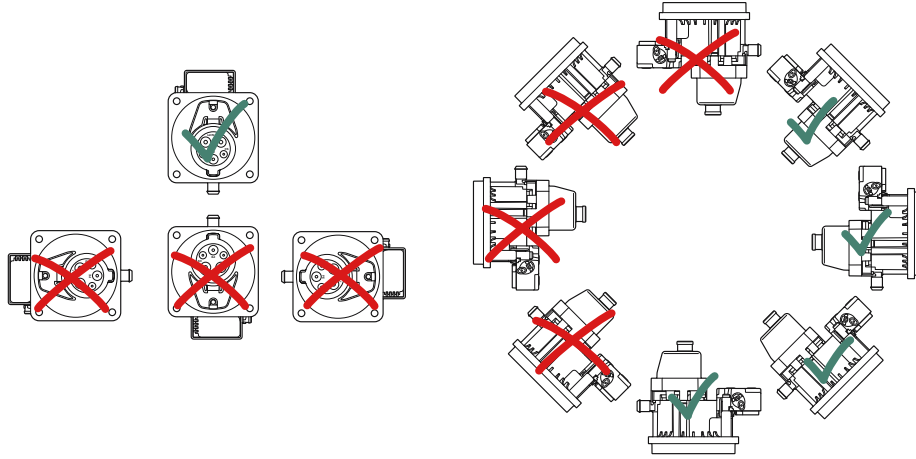

Installation positions

CHARX T1HCI12-1AC48-2,0M1 - Vehicle charging inlet



1271960

<https://www.phoenixcontact.com/pc/products/1271960>

Classifications

ECLASS

ECLASS-11.0	27144706
ECLASS-12.0	27144706
ECLASS-13.0	27144706

ETIM

ETIM 9.0	EC002898
----------	----------

UNSPSC

UNSPSC 21.0	39121800
-------------	----------

CHARX T1HCI12-1AC48-2,0M1 - Vehicle charging inlet



1271960

<https://www.phoenixcontact.com/pc/products/1271960>

Environmental product compliance

REACH SVHC	Lead 7439-92-1
China RoHS	Environmentally Friendly Use Period = 10;
	For information on hazardous substances, refer to the manufacturer's declaration available under "Downloads"

Phoenix Contact 2024 © - all rights reserved

<https://www.phoenixcontact.com>

PHOENIX CONTACT GmbH & Co. KG

Flachsmarktstraße 8

D-32825 Blomberg

+49 (0) 5235-3 00

info@phoenixcontact.com