

CHARX T2HCI24-3AC32-2,0M2 - Vehicle charging inlet



1271965

<https://www.phoenixcontact.com/pc/products/1271965>

Please be informed that the data shown in this PDF document is generated from our online catalog. Please find the complete data in the user documentation. Our general terms of use for downloads are valid.



CHARX connect universal, Vehicle charging inlet, for charging electric vehicles (EV) with alternating current (AC), AC type 2, IEC 62196-2, 32 A / 480 V (AC), Single wires, length: 2 m, locking actuator: 24 V, 4-pos., Front and rear mounting, M6, housing: black, A protective cap is supplied as standard for the AC contacts.

Product description

Vehicle charging inlet for charging with alternating current (AC), compatible with type 2 AC vehicle charging connectors (EVSE), for installation in electric vehicles (EV).

Your advantages

- Complete product range
- Uniform, space-saving dimensions for the installation space and the screw connection points of all Phoenix Contact vehicle charging inlets
- Developed and produced in accordance with the IATF 16949 automotive standard and ISO 9001
- Integrated interlock during charging
- Manual emergency release of the locking actuator
- Protected and sealed against dirt and water with a high degree of protection

Commercial data

Item number	1271965
Packing unit	1 pc
Minimum order quantity	1 pc
Product key	XWCAIC
GTIN	4063151464004
Weight per piece (including packing)	1,775 g
Weight per piece (excluding packing)	1,775 g
Customs tariff number	85444290
Country of origin	PL

CHARX T2HCI24-3AC32-2,0M2 - Vehicle charging inlet



1271965

<https://www.phoenixcontact.com/pc/products/1271965>

Technical data

Notes

General	A protective cap is supplied as standard for the AC contacts.
---------	---

Product properties

Product type	Vehicle charging inlet
Product family	CHARX connect universal
Application	for charging electric vehicles (EV) with alternating current (AC) for installation in electric vehicles (EV)
Charging standard	AC type 2
Charging mode	Mode 2, 3

Electrical properties

Type of signal transmission	Pulse width modulation with modulated Powerline communication in accordance with ISO/IEC 15118 / DIN SPEC 70121
Note on the connection method	Crimp connection, cannot be disconnected
Insulation resistance	> 200 M Ω
Coding	4.7 k Ω (between PE and PP)
Temperature monitoring	AC contacts: PTC chain (DIN EN 60738-1)
Type of charging current	AC 3-phase
Charging power	26 kW
Charging current	32 A

Power contact

Number	5 (L1, L2, L3, N, PE)
Rated voltage	480 V AC
Rated current	32 A AC

Signal contact

Number	2 (CP, PP)
Rated voltage	30 V AC
Rated current	2 A

Temperature sensors (PTC chain)

Sensor type	PTC chain
Standards/regulations	DIN EN 60738-1
Attachment point	Sensor for the AC contacts
Measuring range_resistance	790.00 Ω ... 1420.00 Ω
Resistance	max. 1280 Ω \pm 5 K
Recommended measured current	\leq 1 mA (U_{max} = 16 V DC)
Ambient temperature	-40 $^{\circ}$ C ... 130 $^{\circ}$ C (Operation)

Locking actuator

Operating voltage	24 V
-------------------	------

CHARX T2HCI24-3AC32-2,0M2 - Vehicle charging inlet



1271965

<https://www.phoenixcontact.com/pc/products/1271965>

Note number of positions	4-pos.
Position of the locking actuator	right-side

Locking actuator

Operating voltage	24 V
Note number of positions	4-pos.
Position of the locking actuator	right-side
Possible power supply range at the motor	22 V ... 26 V
Maximum voltage for locking detection	30 V
Typical motor current for locking	0.05 A
Reverse current of the motor	max. 0.5 A
Max. dwell time with reverse current	1 s
Recommended adaptation time	600 ms
Pause time after entry or exit path	3 s
Service life insertion cycles	> 10000 load cycles
Lock recognition	available
Mechanical emergency release	available
Ambient temperature (operation)	-30 °C ... 50 °C

Dimensions

Width	73 mm
Height	73 mm
Depth	73 mm

Material specifications

Color (Housing)	black (9005)
Color (Mating face)	black (9005)
Material (Housing)	Plastic
Material (Contact surface)	Silver

Cable/line

Cable length	2 m
Cable type	Single wires

Single-core wires for AC

Cable length	2 m
Cable structure	5 x 6 mm ²
Single wire, material	Silicone
Single wire, color	OG
External cable diameter	15.90 mm ±0.3 mm
Cable resistance	≤ 3.2 Ω/km

Single-core wire for PE

Cable length	2 m
--------------	-----

Single-core wires for locking actuator

CHARX T2HCI24-3AC32-2,0M2 - Vehicle charging inlet



1271965

<https://www.phoenixcontact.com/pc/products/1271965>

Cable length	0.5 m
Cable structure	4 x 0.5 mm ²
Single wire, material	PVC
Single wire, color	BU/RD, BU/GN, BU/YE, BU/BN
External cable diameter	1.60 mm ±0.20 mm
Cable resistance	≤ 37.1 Ω/m

Single-core wires for PTC temperature sensors

Cable length	1 m
Cable structure	2 x 0.5 mm ²
Single wire, material	PVC
Single wire, color	BN/GY
External cable diameter	1.60 mm ±0.20 mm
Cable resistance	≤ 37.1 Ω/m

Single-core wires for communication

Cable length	1 m
Cable structure	2 x 0.5 mm ²
Single wire, material	PVC
Single wire, color	BK WH
External cable diameter	1.60 mm ±0.20 mm
Cable resistance	≤ 37.1 Ω/m

Mechanical properties

Mechanical data

Insertion/withdrawal cycles	> 10000
Insertion force	< 100 N
Withdrawal force	< 100 N

Environmental and real-life conditions

Ambient conditions

Degree of protection (Vehicle charging inlet)	IP55 (plugged in; when plugged in and ready to operate, the degree of protection is only ensued if both plug-in components are original products from Phoenix Contact or suitable standard-compliant products) IP67 (Inner area of vehicle charging inlet)
Ambient temperature (operation)	-40 °C ... 60 °C
Ambient temperature (storage/transport)	-40 °C ... 85 °C
Altitude	4000 m (above sea level)

Standards and regulations

Standards

Standards/regulations	IEC 62196-2
-----------------------	-------------

CHARX T2HCI24-3AC32-2,0M2 - Vehicle charging inlet



1271965

<https://www.phoenixcontact.com/pc/products/1271965>

Mounting

Mounting type	Front and rear mounting (0 to 90 degree frontal inclination possible)
Mounting hole diameter	6.80 mm (ø)
Fixing screws	M6
Screws included in the scope of delivery	none

CHARX T2HCI24-3AC32-2,0M2 - Vehicle charging inlet



1271965

<https://www.phoenixcontact.com/pc/products/1271965>

Drawings

Schematic diagram

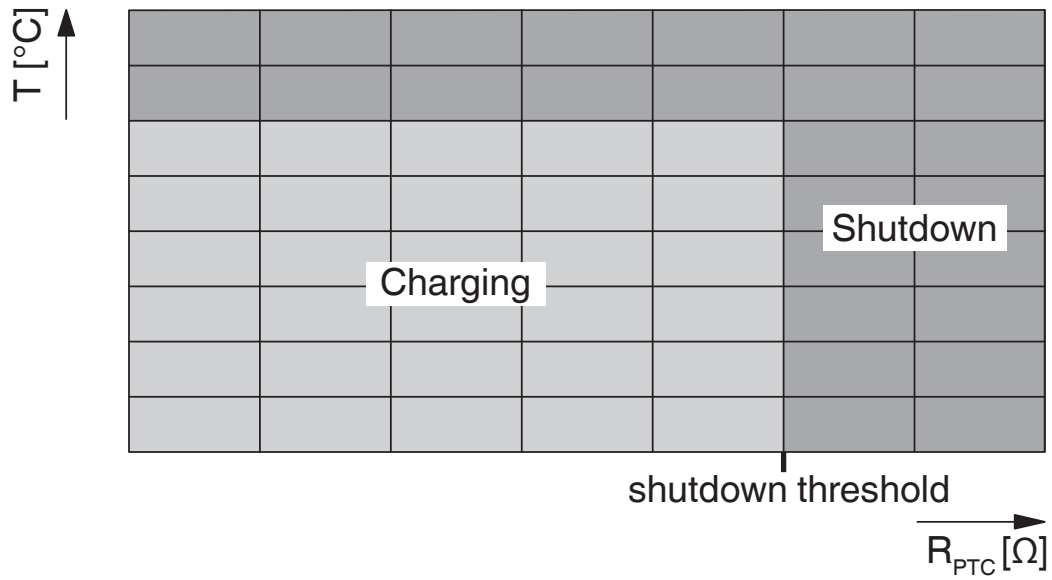

Temperature sensor technology resistance range at AC contacts

Dimensional drawing

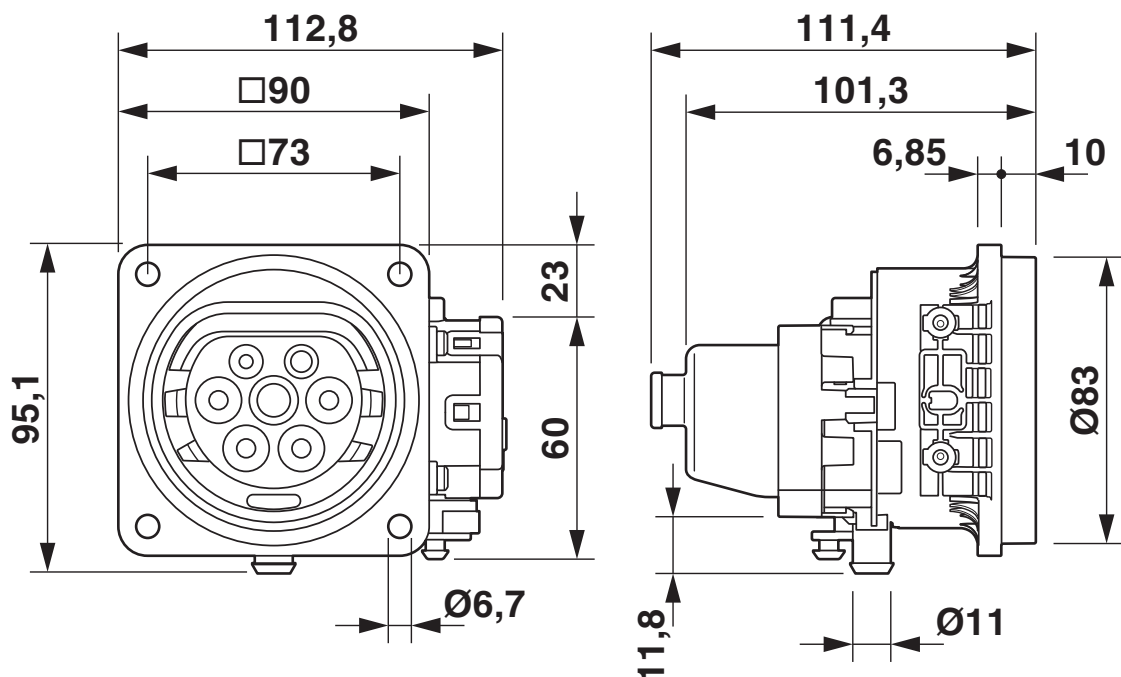

Dimensional drawing

CHARX T2HCI24-3AC32-2,0M2 - Vehicle charging inlet

1271965

<https://www.phoenixcontact.com/pc/products/1271965>

Connection diagram

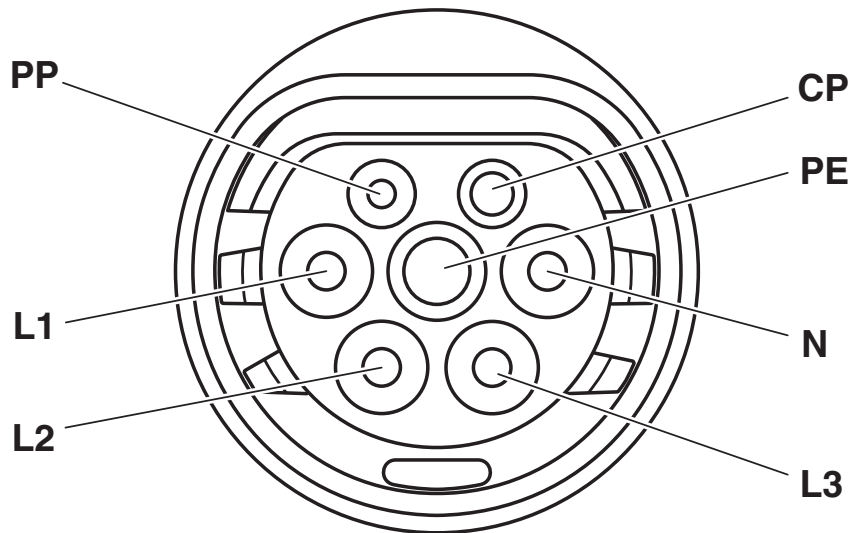

Pin assignment of vehicle charging inlets

Schematic diagram

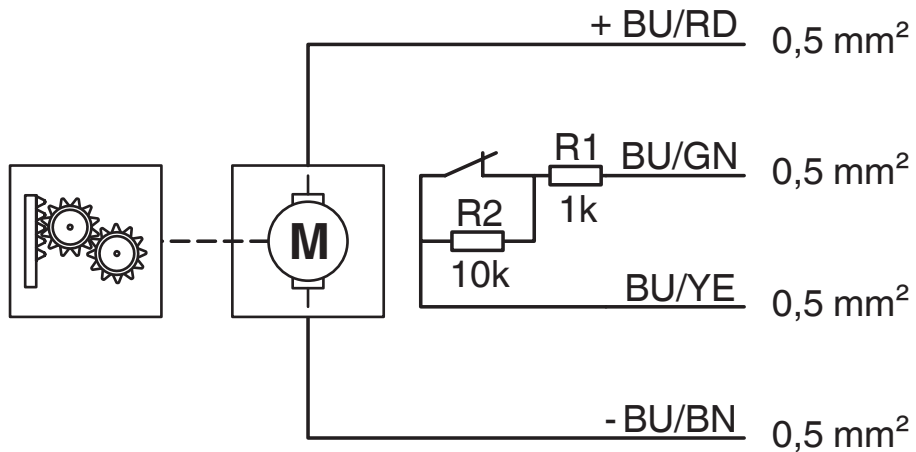

Block diagram of the locking actuator

CHARX T2HCI24-3AC32-2,0M2 - Vehicle charging inlet

1271965

<https://www.phoenixcontact.com/pc/products/1271965>

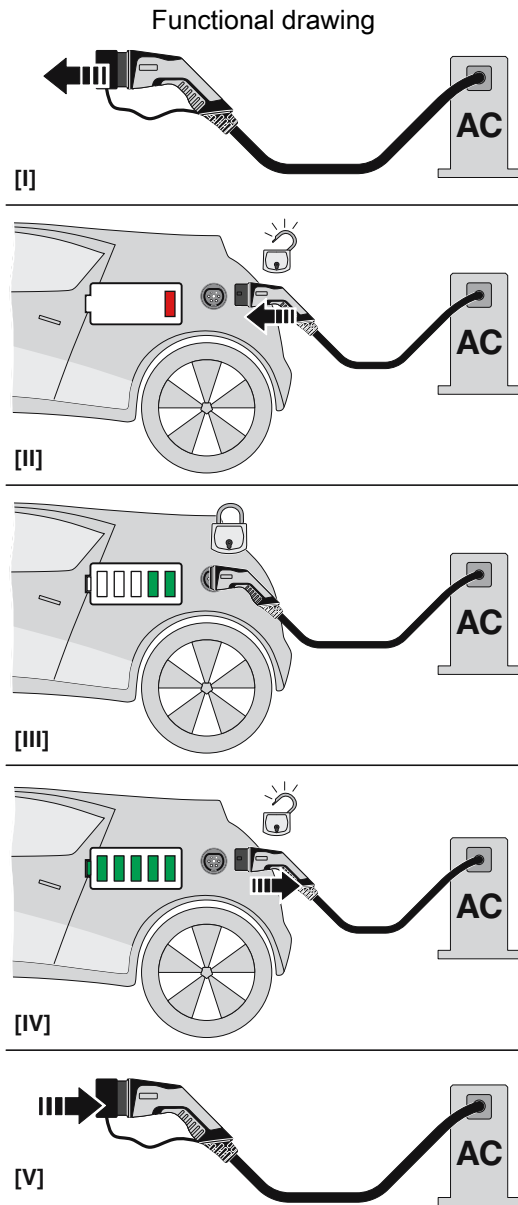

Operating instructions

CHARX T2HCI24-3AC32-2,0M2 - Vehicle charging inlet



1271965

<https://www.phoenixcontact.com/pc/products/1271965>

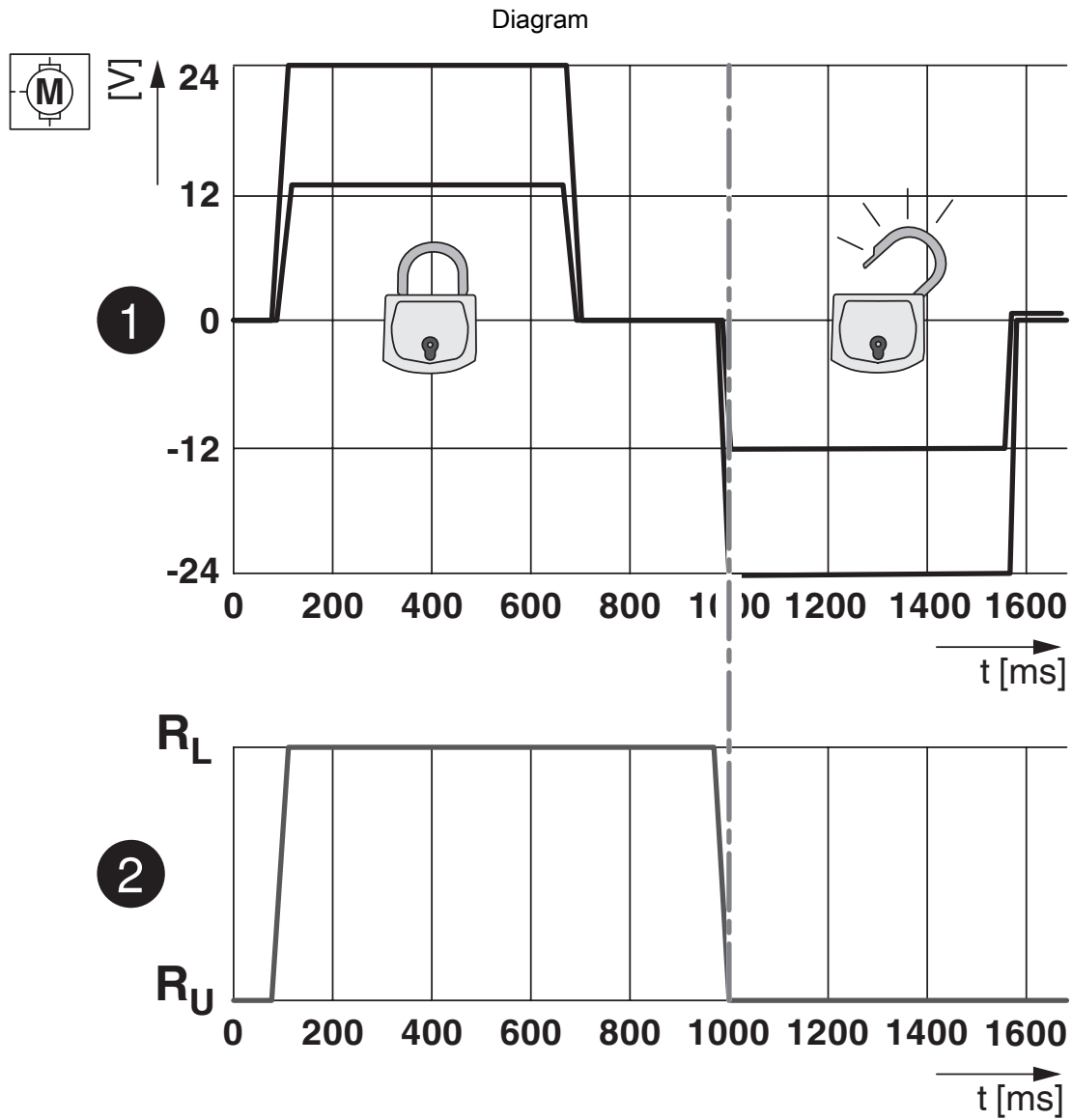

Locking states of the locking actuator

CHARX T2HCI24-3AC32-2,0M2 - Vehicle charging inlet



1271965

<https://www.phoenixcontact.com/pc/products/1271965>

Connection diagram

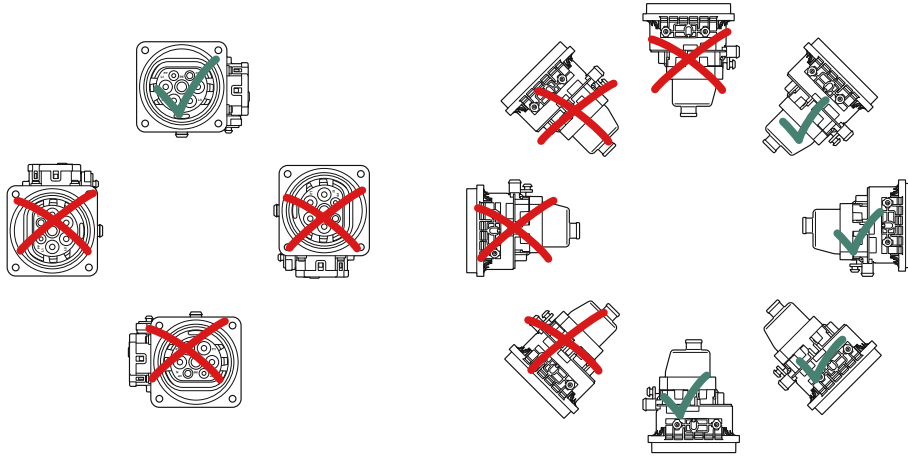

Installation positions

CHARX T2HCI24-3AC32-2,0M2 - Vehicle charging inlet

1271965

<https://www.phoenixcontact.com/pc/products/1271965>

Schematic diagram

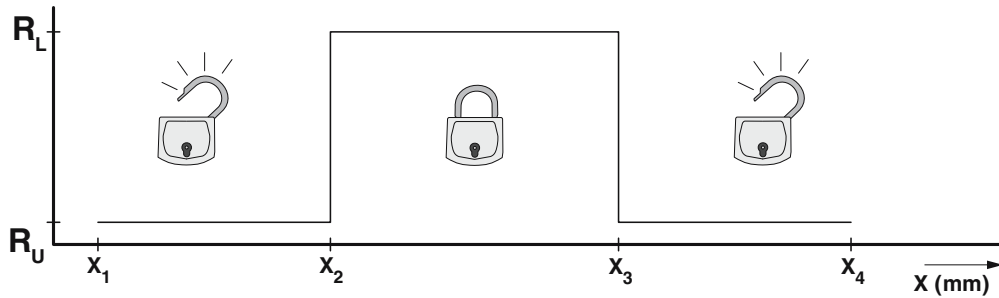

CHARX T2HCI12...: $R_U = 1 \text{ k}\Omega$	$R_L = 11 \text{ k}\Omega$	$R_U = 1 \text{ k}\Omega$
CHARX T2HCI24...: $R_U = \infty \text{ k}\Omega$	$R_L = 0 \text{ k}\Omega$	$R_U = \infty \text{ k}\Omega$

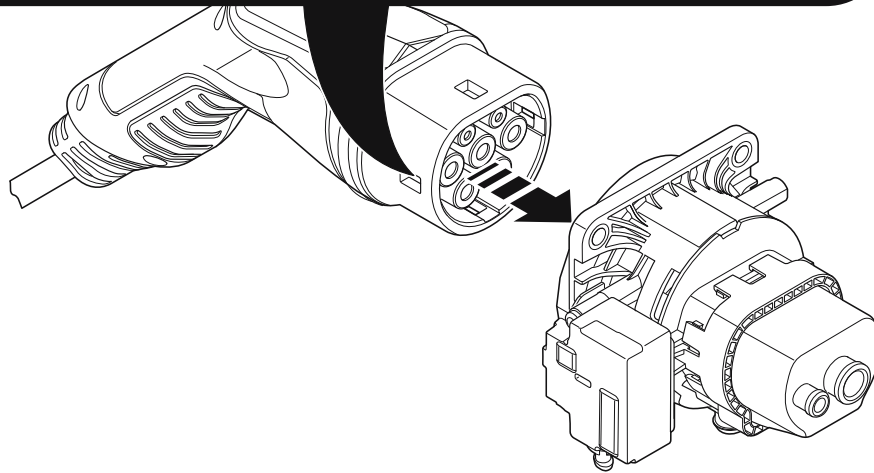

Detection for Vehicle Connector

CHARX T2HCI24-3AC32-2,0M2 - Vehicle charging inlet



1271965

<https://www.phoenixcontact.com/pc/products/1271965>

Classifications

ECLASS

ECLASS-11.0	27144706
ECLASS-12.0	27144706
ECLASS-13.0	27144706

ETIM

ETIM 9.0	EC002898
----------	----------

CHARX T2HCI24-3AC32-2,0M2 - Vehicle charging inlet



1271965

<https://www.phoenixcontact.com/pc/products/1271965>

Environmental product compliance

REACH SVHC	Lead 7439-92-1
China RoHS	Environmentally Friendly Use Period = 10;
	For information on hazardous substances, refer to the manufacturer's declaration available under "Downloads"

CHARX T2HCI24-3AC32-2,0M2 - Vehicle charging inlet



1271965

<https://www.phoenixcontact.com/pc/products/1271965>

Accessories

CHARX T2HI-ELOCK24V - Locking

1331524

<https://www.phoenixcontact.com/pc/products/1331524>

CHARX connect universal, Locking, Accessories, for mounting on vehicle charging inlets, Type 2, IEC 61851-1, Single wires, length: 1 m, locking actuator: 24 V, 4-pos.



Phoenix Contact 2024 © - all rights reserved
<https://www.phoenixcontact.com>

PHOENIX CONTACT GmbH & Co. KG
Flachsmarktstraße 8
D-32825 Blomberg
+49 (0) 5235-3 00
info@phoenixcontact.com