

Data sheet

**M12 Industrial Ethernet cable, X-coded, 2.0 m,
M12 plug straight - M12 plug angled, coding at 225°, PUR**

Page 1/4

P/N
142M2X1C020
EAN 4251394609034
2023/05/10
Version: K

Illustrations



Dimensional drawing

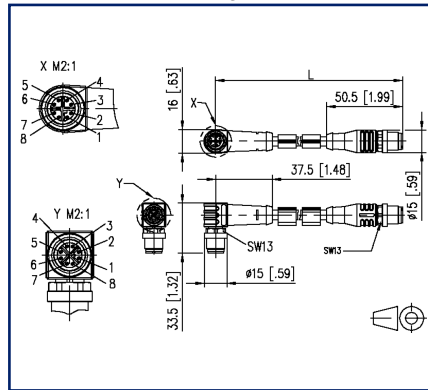

Wiring diagram

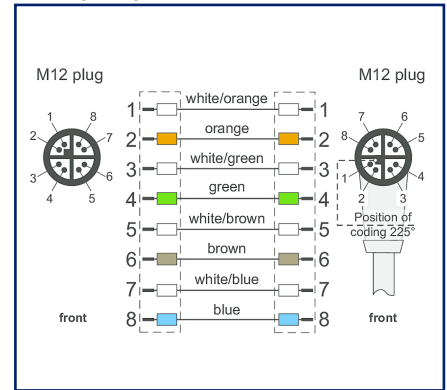

See enlarged drawings at the end of document

Product specification

Shielded PUR cable for safe and industrial data transmission in automation and fieldbus technology. The cable meets the requirements of ULStyle 20963 and complies with Cat7 (electrical properties based on EN50288-4-2). Materials and design allow increased mechanical stress (abrasion, bending, vibration, etc.) of the cable. Special properties: UL style 20963, seawater resistant, recyclable, LABS free, RoHs compliant, acid and alkali resistant, UV resistant, hydrolysis resistant, halogen free, oil resistant, high flexibility, no corrosive gases, microbe resistant, no fire propagation.

- Standard variants: 1.0 m, 2.0 m, 5.0 m, 10.0 m.
- Other cable lengths on request.

P | Cabling

Data sheet

Page 2/4

**M12 Industrial Ethernet cable, X-coded, 2.0 m,
M12 plug straight - M12 plug angled, coding at 225°, PUR**

P/N

142M2X1C020

EAN 4251394609034

2023/05/10

Version: K

Technical Data

P | Cabling

Data sheet

Page 3/4

**M12 Industrial Ethernet cable, X-coded, 2.0 m,
M12 plug straight - M12 plug angled, coding at 225°, PUR**

P/N
142M2X1C020
EAN 4251394609034
2023/05/10
Version: K

Illustrations

Dimensional drawing

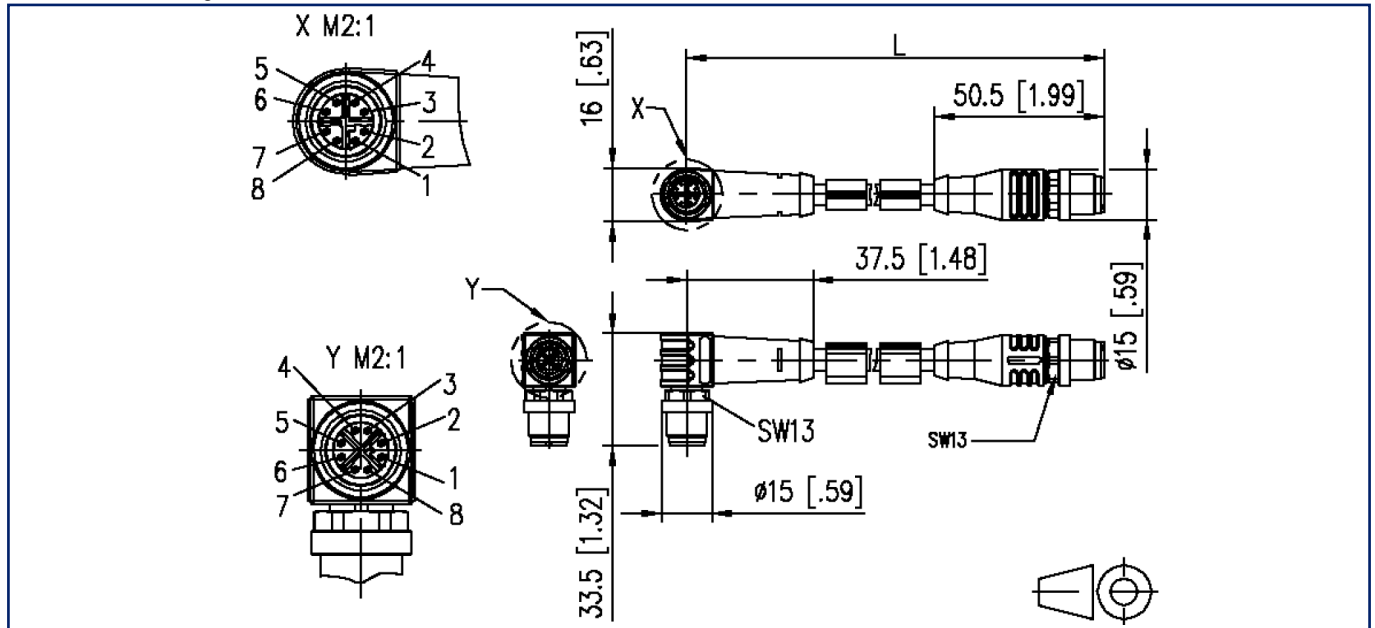

Wiring diagram

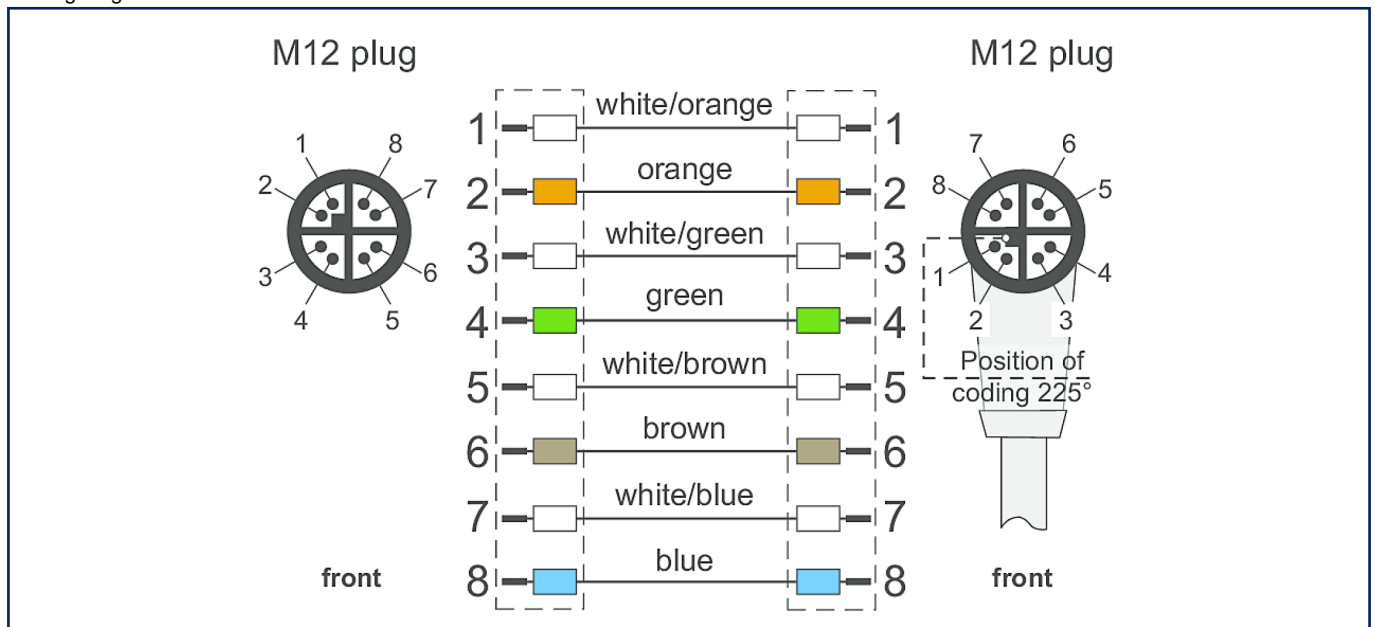

P | Cabling

Data sheet

Page 4/4

**M12 Industrial Ethernet cable, X-coded, 2.0 m,
M12 plug straight - M12 plug angled, coding at 225°, PUR**

P/N

142M2X1C020

EAN 4251394609034

2023/05/10

Version: K

Illustrations

Principle diagram

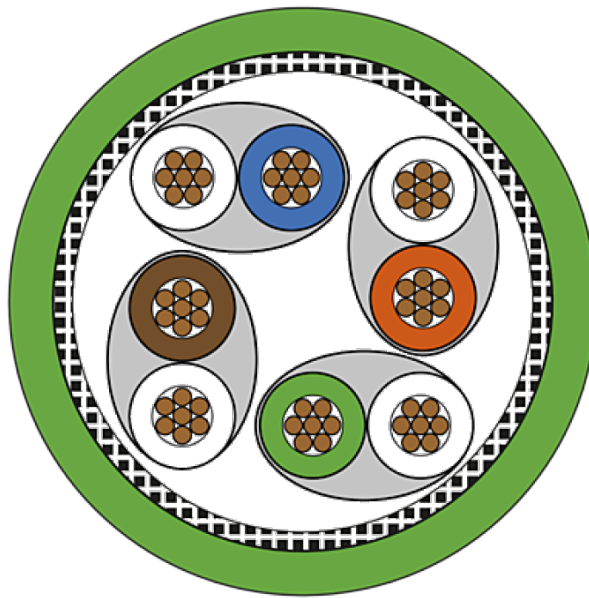

© 2023 METZ CONNECT - Technische Änderungen vorbehalten! Subject to modifications! Sous réserve de modifications techniques!

