

used for: D-SUB

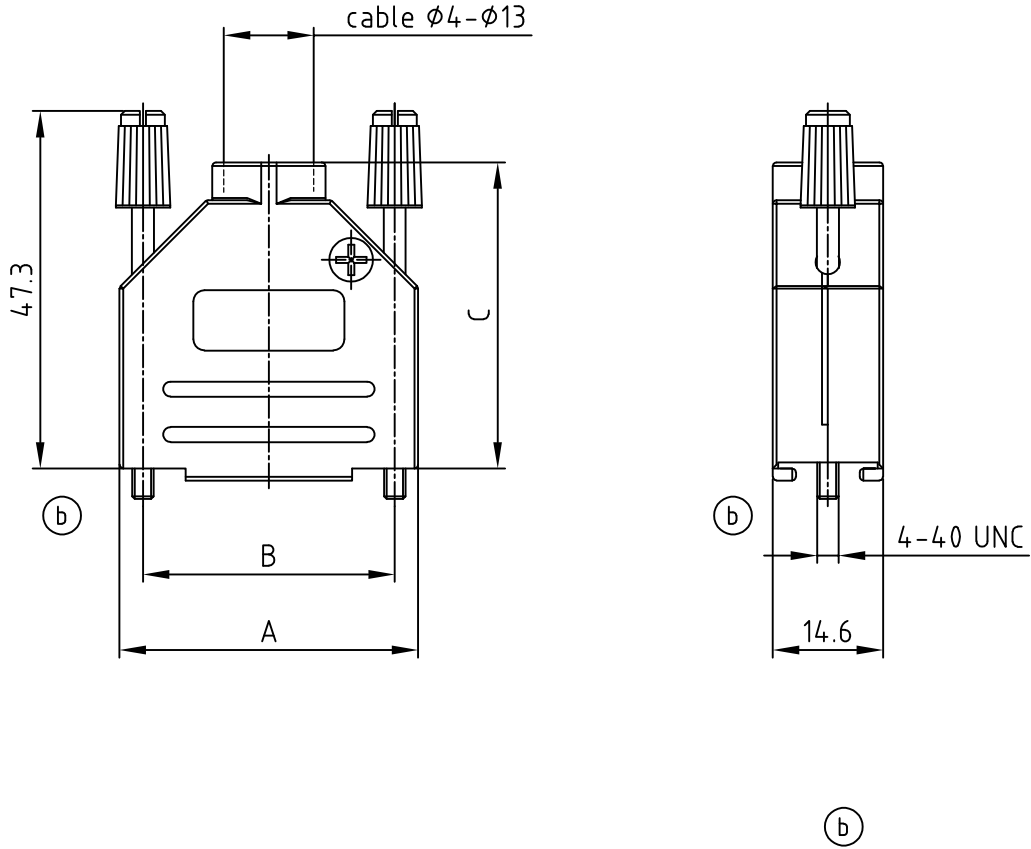

No. of pos.	A	B	C	Part NO.
9	31.2	25.0	38.3	165X02609X
15	39.3	33.3	40.5	165X02619X
25	53.4	47.0	47.8	165X02629X
37	69.9	63.5	52.2	165X02639X

(b) TECHNICAL DATA:

1. BACKSHELL HALVES: ZINC DIE-CAST; NICKEL PLATED
2. ASSEMBLY SCREWS: STEEL; TIN PLATED
3. JACK SCREWS: STEEL; TIN PLATED + PA6
4. CABLE STRAIN RELIEF: PC
5. TEMPERATURE RANGE:  $-40^{\circ}\text{C}$  to  $+120^{\circ}\text{C}$
6. ATTENUATION FACTOR:  $>40\text{dB}$  BETWEEN 30 MHz AND 1 GHz
7. ASSEMBLY INSTRUCTION SEE SHEET 2

RoHS compliant

THIS DRAWING MAY NOT BE COPIED OR REPRODUCED IN ANY WAY, AND MAY NOT BE PASSED ON TO A THIRD PARTY WITHOUT WRITTEN PERMISSION.  
 OWNERSHIP AND COPYRIGHT OF CONEC GmbH  
 DO NOT ALTER CAD DRAWING BY HAND

				tolerance		dim. in mm	
				2002	date	name	
				drawn	18.07.	Parei	
				appd.	18.07.	E. Mickenbecker	
				norm			
				d-old			
4 x b	Ä 4169	30.11.2011	Lehmen.	<b>CONEC</b> <sup>®</sup>			
a	Original						
rev.	description	date	name				

scale: 1:1	
material: SEE NOTES	
title: METAL HOOD 9-37pos. EMI/RFI SHIELDING with straight cable exit and jack screws	
dwg no: 16K1A714	DIN-A 4 sh:1/2
part no: SEE TABLE	

4

3

2

1

used for:

D-SUB

## ASSEMBLY INSTRUCTION:

C

Use two halves of the strain relief and attach around the outer cable jacket. Different sizes of the strain relief can be mixed together to give the best fit. For cable diameters exceeding 9 mm, assembly without strain relief or with just one strain relief half is applicable.

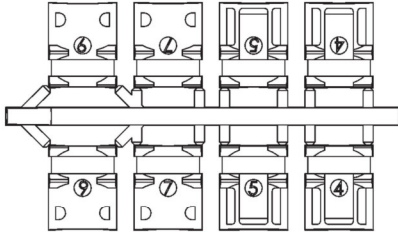

Strip the outer jacket 18 mm as illustrated below.

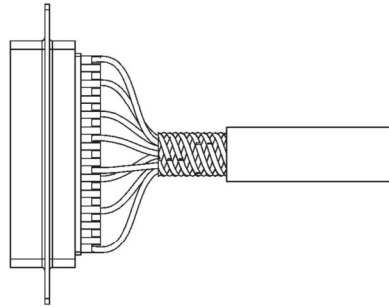

Split and pigtail the braid as illustrated below.

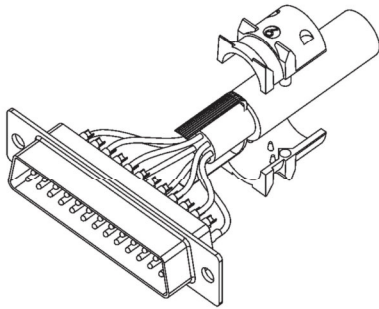

Turn the pigtail cable shield back over the strain relief. If not using any strain relief from the supplied set, use the same procedure around the outer cable jacket.

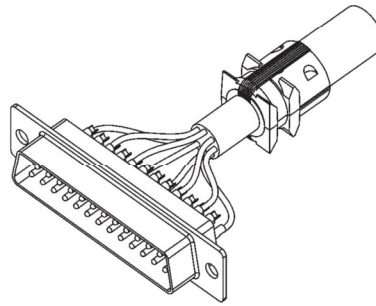

Place the assembled connectors and cable into the bottom back shell half.

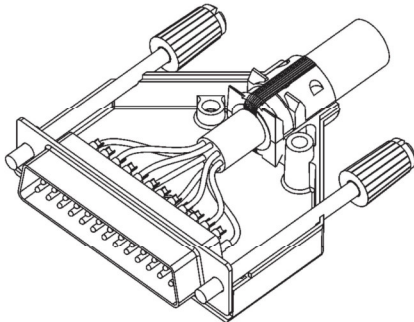

Complete the assembly by putting the top half over the assembly and tighten with accompanied assembly screws. Maximum mounting torque is 100 - 120 Ncm.

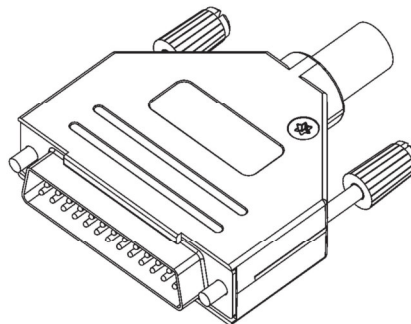

THIS DRAWING MAY NOT BE COPIED OR REPRODUCED IN ANY WAY, AND MAY NOT BE PASSED ON TO A THIRD PARTY WITHOUT WRITTEN PERMISSION.  
OWNERSHIP AND COPYRIGHT OF CONEC GmbH  
DO NOT ALTER CAD DRAWING BY HAND

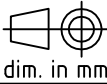
			tolerance		 dim. in mm
			2011	date	name
			drawn	30.11.	Lehmenkühler
			appd.	30.11.	Fischer
			norm		
			d-old		
1 x c	Ä 6274	22.08.2016	Unkrüer		
a	Original				
rev.	description	date	name		



scale:  
material:

title:  
ASSEMBLY INSTRUCTION  
METAL HOOD 9-37pos. EMI/RFI SHIELDING  
with straight cable exit and jack screws

dwg no:

16K1A714

DIN-A  
4  
sh:2/2

part no:

SEE SHEET 1

4

3

2

1

B

C

D

E

F

B

C

D

E

F

A

A