

# Cabinet Accessories–Electrics

## GND/EARTHING RAIL

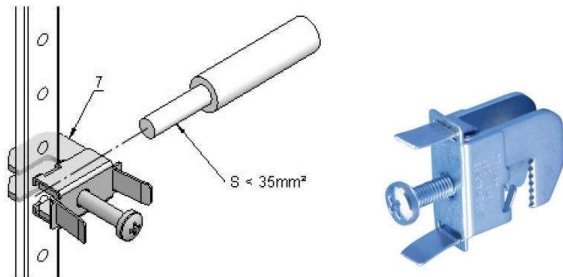
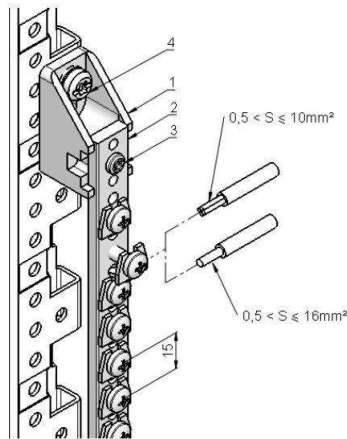

Pos. 7

- To connect GND/earthing wire and stranded conductors by means of terminal clamps

- Fixing insulated from the frame

### DELIVERY COMPRISES

Item	Qty	Description
1	2/3	Rail support block
2	1	Rail, Cu, cross Lx15x5 mm, screw-on point M5, distance 15mm, screw M5 and washer included
3	2/3	Screw D4x14, Torx 20
4	2/3	Combiscrew M6x13, Torx 30
	1	Assembly kit for cabinet assembly

Remark: 200 + 440mm versions include only 2 support blocks and 2 screws

### ORDER INFORMATION

Length mm	Part no.
200	<b>20118-859</b>
450	<b>20118-865</b>
975	<b>20118-866</b>
1680	<b>20118-867</b>
1900	<b>20118-868</b>
1980	<b>20118-869</b>

### Accessories

Pos. 7, terminal clamps, PU 20 pcs	<b>21120-209</b>
------------------------------------	------------------

<b>Delivery: supplied loose with cabinet or frame</b>	<b>Part no./35</b>
---	--------------------

### NOTE

- Please order terminal clamps (pos.7) separately

## GND/EARTHING RAIL, FLAT STRIP

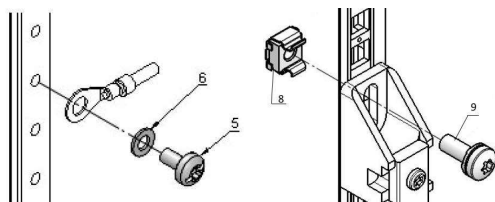
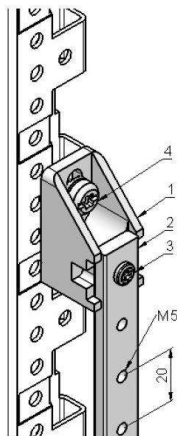

- To screw on GND/earthing cables with ring tags
- Threaded fixing points M5 in intervals of 20 mm
- Fixing insulated from the frame

### DELIVERY COMPRISES

Item	Qty	Description
1	2/3	Rail support block
2	1	Rail, Cu, cross Lx15x5 mm, screw-on point distance 20mm, M5
3	2/3	Screw D4x14, Torx 20
4	2/3	Combiscrew M6x13, Torx 30
	1	Assembly kit for cabinet assembly

Remark: 440mm version include only 2 support blocks and 2 screws

### ORDER INFORMATION

Description	L in mm	Qty/PU	Part no.
GND/earthing rail, flat strip	440	10	<b>20118-860</b>
GND/earthing rail, flat strip	980	10	<b>20118-861</b>
GND/earthing rail, flat strip	1680	10	<b>20118-862</b>
GND/earthing rail, flat strip	1900	10	<b>20118-863</b>
GND/earthing rail, flat strip	2000	10	<b>20118-864</b>

### Accessories

Pos. 5 + 6 Screw M5 x 10, St and Washer A5, PU 50 pcs	<b>21120-208</b>
---	------------------

Pos. 8 Cage Nut M6, St, zinc, PU 50 pcs	<b>21100-003</b>
---	------------------

Pos. 9 Screw M6 x 16 St, Torx30, PU 50 pcs	<b>21120-200</b>
--	------------------

<b>Delivery: supplied loose with cabinet or frame</b>	<b>Part no./35</b>
---	--------------------

### NOTE

- Please order panhead screw M5 to screw on GND/earth cable separately