

THIS DRAWING IS UNPUBLISHED. RELEASED FOR PUBLICATION
 © COPYRIGHT BY TYCO ELECTRONICS CORPORATION. ALL INTERNATIONAL RIGHTS RESERVED.

LOC	DIST	REVISIONS			
P	LTR	DESCRIPTION	DATE	DWN	APVD
FT	0	N	REVISED PER ECO-08-029122	22NOV08	HMR MS
		N1	REVISED PER ECO-09-021826	11JAN10	KK AEG

- 1 PART PACKAGED UNASSEMBLED.
- 2 CABLE CLAMPING AREA ADJUSTABLE FROM .010 TO .161 SQ IN BY REVERSING CLAMPING INSERTS. (2 INSERTS SUPPLIED)
- 3 CABLE CLAMPING AREA ADJUSTABLE FROM .010 TO .161 SQ IN BY CHANGING CLAMPING INSERTS. (4 INSERTS SUPPLIED, -4 ONLY)
- 4 .453 MAXIMUM CABLE OUTSIDE DIAMETER.
- 5 BULK PACKAGED KITS TO BE ORDERED IN MULTIPLES OF 200 ONLY.
- 6 NON-HEXAVALENT CHROMATE FINISH.
- 7 OBSOLETE PARTS: OBSOLETE CIS STREAMLINING PER D.RENAUD/D.SINISI

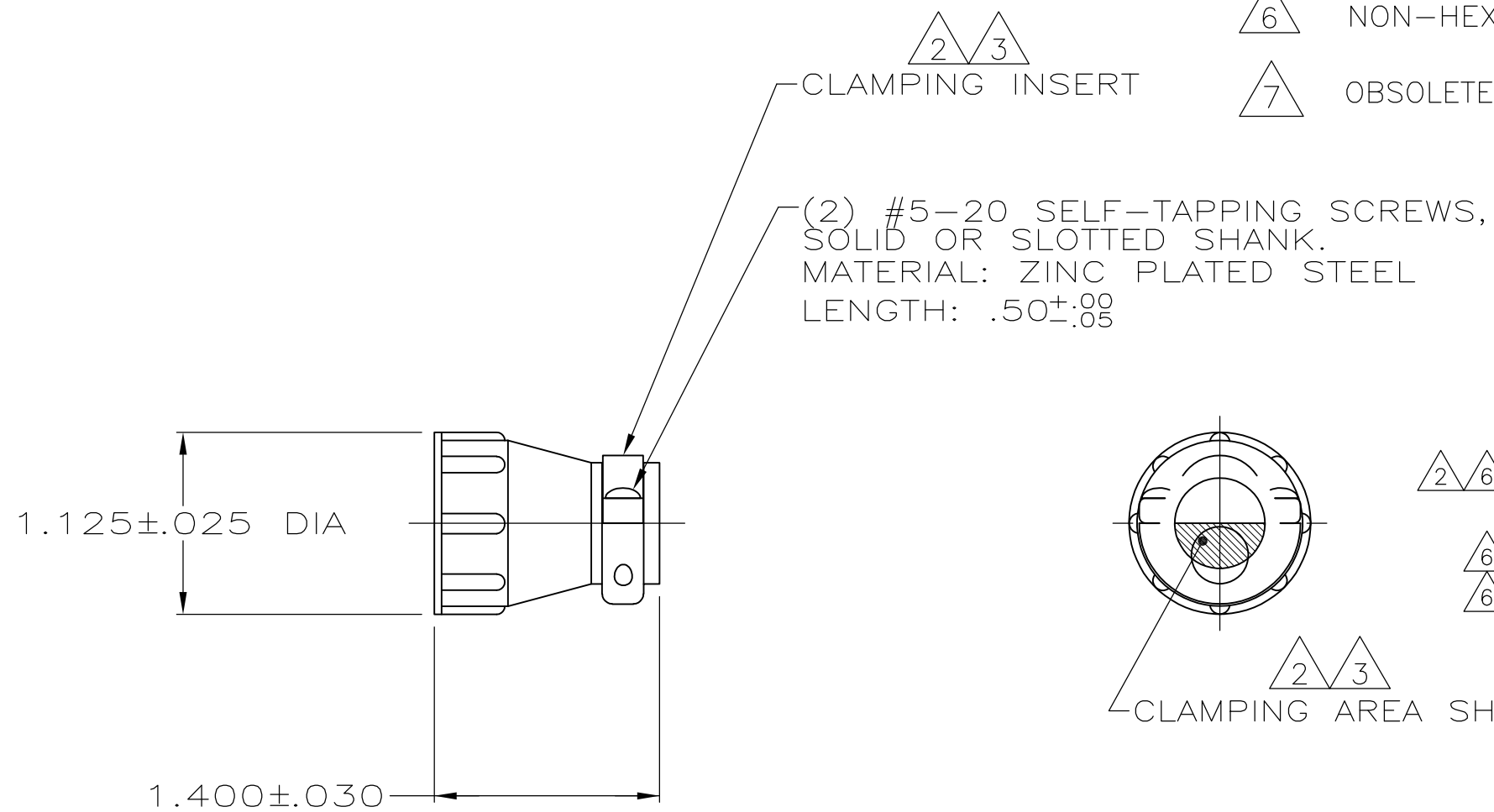

PACKAGING	PART NUMBER
INDIVIDUAL	1-206070-1
BULK	1-206070-0
OBSOLETE SMALL PACK	206070-9
INDIVIDUAL	206070-8
OBSOLETE INDIVIDUAL	206070-7
OBSOLETE SMALL PACK	206070-6
OBSOLETE BULK	206070-4
BULK	206070-3
INDIVIDUAL	206070-1

THIS DRAWING IS A CONTROLLED DOCUMENT.		DWN A GRAFF 4/23/91	Tyco Electronics Corporation Harrisburg, PA 17105-3608	
DIMENSIONS: INCHES		CHK W.G.LENKER 7-22-92	NAME CABLE CLAMP KIT, STANDARD, SHELL SIZE 17, CPC	
TOLERANCES UNLESS OTHERWISE SPECIFIED:		APVD -	PRODUCT SPEC 108-10024	
MATERIAL THERMOPLASTIC		FINISH -	APPLICATION SPEC -	RESTRICTED TO -
		WEIGHT -	SIZE A3	CAGE CODE 00779
		DRAWING NO C-206070		SCALE NTS
		CUSTOMER DRAWING		SHEET 1 OF 1
				REV N1