

QUINT-ORING/24DC/2X20/1X40

Active redundancy module

Data sheet
104623_en_06

© PHOENIX CONTACT 2015-07-15

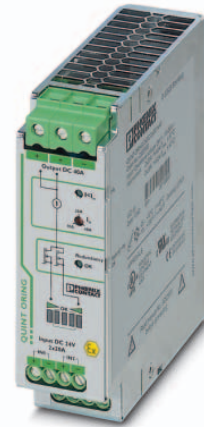

1 Description

QUINT ORING is the DIN-rail mountable active redundancy module from the QUINT POWER product range.

With the help of the redundancy module, two power supply units of the same type switched for redundancy on the output side are decoupled 100% from each other.

Redundant systems are used in plants that make particularly high demands on operational safety. The power supply units involved must be dimensioned to enable the total current requirements of all loads to be covered by one single power supply unit.

If the total requirement increases, e. g., due to additionally installed loads, and exceeds the nominal current of the power supply units, the power supply unit system is no longer redundant. A defect in the power supply unit or the wiring can also lead to loss of redundancy.

This can be detected immediately via a floating signal contact and a corresponding LED.

The Auto Current Balance (ACB) technology allows even current distribution of the load current to the connected power supply units, which decisively increases the service life of the redundant system.

Features

- low-loss decoupling of power supply units connected in parallel
- Preventive function monitoring
- Auto Current Balance technology



Make sure you always use the latest documentation.
It can be downloaded from the product at phoenixcontact.net/products.

2	Table of contents	
1	Description	1
2	Table of contents	2
3	Ordering data	3
4	Technical data	4
5	Safety regulations and installation notes.....	8
6	Structure	9
7	Basic circuit diagram	9
8	Installation	9
9	Mounting position	10
10	Mounting on DIN rails	11
11	Input	11
12	Output.....	11
13	Signaling.....	12
	13.1 "Redundancy OK" floating signal contact	13
	13.2 "ACB OK" floating signal contact	13
14	Function.....	13
	14.1 Input/output	13
	14.2 ACB technology	13
	14.3 Protection against static surge voltage	13
15	Derating.....	14
	15.1 Temperature response	14
	15.2 Position-dependent derating.....	14

3 Ordering data

Description	Type	Order No.	Pcs./Pkt.
Active QUINT redundancy module for DIN rail mounting with ACB technology (Active Current Balancing) and monitoring functions, input: 24 V DC, output: 24 V DC/2 x 20 A or 1 x 40 A, including mounted universal DIN rail adapter UTA 107/30	QUINT-ORING/24DC/2X20/1X40	2320186	1
Accessories	Type	Order No.	Pcs./Pkt.
Universal DIN rail adapter	UTA 107/30	2320089	100
Universal wall adapter	UWA 182/52	2938235	1
Assembly adapter for QUINT-PS... power supply on S7-300 rail	QUINT-PS-ADAPTERS7/1	2938196	1



Our range of accessories is being continually extended, our current range can be found in the download area.

4 Technical data

Input data/output data	
Nominal input voltage	24 V DC
Input voltage range	18 V DC ... 28 V DC (SELV)
Voltage drop, input/output	0.2 V ($I_{OUT} = 40$ A)
Nominal current	2x 20 A (-25 °C ... 60 °C) 1x 40 A (-25 °C ... 60 °C)
Maximum current	2x 26 A (-25 °C ... 40 °C) 1x 52 A (-25 °C ... 40 °C) 120 A (12 ms, SFB Technology)
Transient surge protection	Varistor
Protection against polarity reversal	Yes, < 60 V
Protective circuit	Protection against static surge voltages > 30 V
Nominal output voltage	0.2 V (< DC input)
Output current	40 A (Increasing power) 20 A (Redundancy)
Derating	60 °C ... 70 °C (2.5%/K)
Power loss nominal load max.	8 W ($I_{OUT} = 40$ A)
Efficiency	> 98 %
Protection against surge voltage on the output	≤ 32 V DC

Redundancy OK, 13/14	
Output description	Group contact
Voltage	max. 30 V AC/DC
Current	≤ 100 mA (short-circuit resistant)
Status display	LED redundancy OK / Green

ACB (Auto Current Balancing) OK, 23/24	
Output description	Contact closed: $\Delta U_{IN} \leq 300$ mV
Voltage	max. 30 V AC/DC
Current	≤ 100 mA (short-circuit resistant)
Status display	ACB OK LED / LED bar graph green

General data	
Insulation voltage input, output / housing	500 V
MTBF (IEC 61709, SN 29500)	> 720000 h (40 °C)
Mounting position	horizontal DIN rail NS 35, EN 60715
Dimensions W/H/D	38 mm / 130 mm / 125 mm
Dimensions W / H / D (90° turned)	122 mm / 130 mm / 41 mm
Weight	0.6 kg

Security	
Degree of protection	IP20
Protection class	III
SELV	IEC 60950-1 (SELV) and EN 60204-1 (PELV)

Input connection data

Connection method	Screw connection
Conductor cross section, solid	0.2 mm ² ... 6 mm ²
Conductor cross section, flexible	0.2 mm ² ... 4 mm ²
Conductor cross section AWG	10
Stripping length	8 mm
Screw thread	M3
Tightening torque	0.5 Nm ... 0.6 Nm

Output connection data

Connection method	Screw connection
Conductor cross section, solid	0.5 mm ² ... 16 mm ²
Conductor cross section, flexible	0.5 mm ² ... 16 mm ²
Conductor cross section AWG	6
Stripping length	10 mm
Screw thread	M4
Tightening torque	1.2 Nm ... 1.5 Nm

Signal connection data

Connection method	Screw connection
Conductor cross section, solid	0.2 mm ² ... 6 mm ²
Conductor cross section, flexible	0.2 mm ² ... 4 mm ²
Conductor cross section AWG	16 ... 10
Stripping length	10 mm
Screw thread	M3
Tightening torque	0.5 Nm ... 0.6 Nm

Ambient conditions

Ambient temperature (operation)	-25 °C ... 70 °C (> 60 °C Derating: 2,5 %/K)
Ambient temperature (start-up type tested)	-40 °C
Ambient temperature (storage/transport)	-40 °C ... 85 °C
Max. permissible relative humidity (operation)	≤ 100 % (at 25 °C, non-condensing)
Vibration (operation)	< 15 Hz, amplitude ±2.5 mm (according to IEC 60068-2-6) 15 Hz ... 150 Hz, 2.3g, 90 min.
Shock	30g in each direction, according to IEC 60068-2-27
Pollution degree in acc. with EN 50178	2
Climatic class	3K3 (in acc. with EN 60721)

Standards

Electrical Equipment for Machinery	EN 60204-1
Electrical safety (of information technology equipment)	EN 60950-1/VDE 0805 (SELV)
Electronic equipment for use in electrical power installations	EN 50178/VDE 0160 (PELV)
SELV	IEC 60950-1 (SELV) and EN 60204-1 (PELV)

Approvals

ATEX

Ex II 3 G Ex nA IIC T4 Gc

IECEX

Ex nA IIC T4 Gc

UL approvals

UL/C-UL listed UL 508

UL/C-UL Recognized UL 60950

UL ANSI/ISA-12.12.01 Class I, Division 2, Groups A, B, C, D (Hazardous Location)



Current approvals/permissions for the product can be found in the download area under phoenixcontact.net/products.

Conformance with EMC Directive 2004/108/EC

Noise immunity according to EN 61000-6-2

	EN 61000-6-2 requirement	Tested
Electrostatic discharge EN 61000-4-2		
Housing contact discharge	4 kV (Test intensity 2)	8 kV (Test intensity 4)
Housing air discharge	8 kV (Test intensity 3)	15 kV (Test intensity 4)
Comments	Criterion B	Criterion B
Electromagnetic HF field EN 61000-4-3		
Frequency range	80 MHz ... 1 GHz	80 MHz ... 1 GHz
Test field strength	10 V/m (Test intensity 3)	20 V/m (Test intensity 3)
Frequency range	1.4 GHz ... 2 GHz	1 GHz ... 2 GHz
Test field strength	3 V/m (Test intensity 2)	10 V/m (Test intensity 3)
Frequency range	2 GHz ... 2.7 GHz	2 GHz ... 3 GHz
Test field strength	1 V/m (Test intensity 1)	10 V/m (Test intensity 3)
Comments	Criterion A	Criterion A
Fast transients (burst) EN 61000-4-4		
Input	2 kV (Test intensity 3 - asymmetrical)	2 kV (Test intensity 3 - asymmetrical)
Output	2 kV (Test intensity 3 - asymmetrical)	2 kV (Test intensity 3 - asymmetrical)
Signal	1 kV (Test intensity 3 - asymmetrical)	2 kV (Test intensity 4 - asymmetrical)
Comments	Criterion B	Criterion B
Surge current loads (surge) EN 61000-4-5		
Input	0.5 kV (Test intensity 1 - symmetrical) 0.5 kV (Test intensity 1 - asymmetrical)	1 kV (Test intensity 2 - symmetrical) 2 kV (Test intensity 3 - asymmetrical)
Output	0.5 kV (Test intensity 1 - symmetrical) 0.5 kV (Test intensity 1 - asymmetrical)	1 kV (Test intensity 2 - symmetrical) 2 kV (Test intensity 3 - asymmetrical)
Signal	1 kV (Test intensity 2 - asymmetrical)	1 kV (Test intensity 2 - asymmetrical)
Comments	Criterion B	Criterion B
Conducted interference EN 61000-4-6		
Input/Output/Signal	asymmetrical	asymmetrical
Frequency range	0.15 MHz ... 80 MHz	0.15 MHz ... 80 MHz
Voltage	10 V (Test intensity 3)	10 V (Test intensity 3)
Comments	Criterion A	Criterion A

Key

Criterion A	Normal operating behavior within the specified limits.
Criterion B	Temporary impairment to operational behavior that is corrected by the device itself.

Emitted interference in acc. with EN 61000-6-3

Radio interference voltage in acc. with EN 55011	EN 55011 (EN 55022) Class B, area of application: Industry and residential
Emitted radio interference in acc. with EN 55011	EN 55011 (EN 55022) Class B, area of application: Industry and residential



All technical specifications are nominal values and refer to a room temperature of 25 °C and 70 % relative humidity at 100 m above sea level.

5 Safety regulations and installation notes

**EXPLOSION HAZARD**

Only remove equipment when it is disconnected and not in the potentially explosive area!

DANGER

Never carry out work on live parts!
The housing can become very hot, depending on the ambient temperature and load!

**CAUTION:**

Before startup please ensure:

The connection must be carried out by a competent person and protection against electric shock guaranteed.

It must be possible to switch off power to device according to EN 60950.

All feed lines are sufficiently protected and dimensioned!

All output lines are dimensioned according to the maximum output current of the device or separately protected!

Sufficient convection must be guaranteed.

**NOTE: Danger if used improperly**

The redundancy module is a device installing into an enclosed space. Installation and start-up may only be carried out by qualified personnel. The relevant country-specific regulations must be observed.

6 Structure

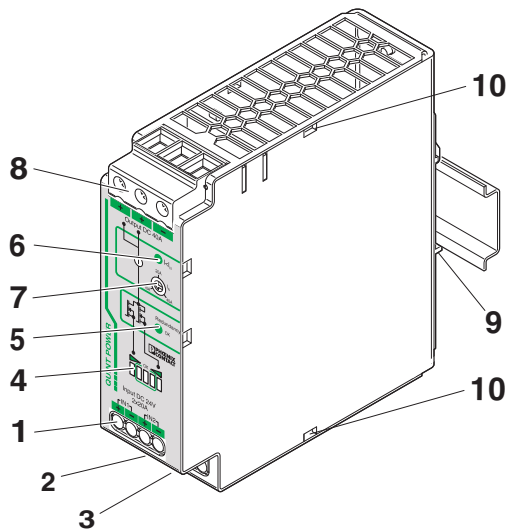
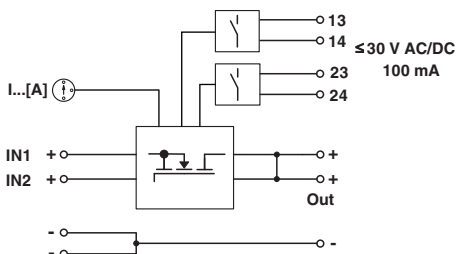

Figure 1 Function elements

- 1 IN1/IN2 DC input:
24 V input voltage, $I_N = 2 \times 20 \text{ A}$
- 2 Floating relay contact
13/14 "Redundancy OK"
(max. 30 V, 100 mA, short-circuit-proof)
- 3 Floating relay contact
23/24 "ACB OK"
(max. 30 V, 100 mA, short-circuit-proof)
- 4 Bar graph for displaying the current balance I_1/I_2
- 5 "Redundancy OK" LED, green
- 6 LED " $I < I_N$ ", green
- 7 Rotary selector switch for selecting the nominal current of the power supply units
- 8 DC output approx. $0.2 \text{ V} < \text{DC input}$
- 9 Universal snap-on foot for EN DIN rails
- 10 Strain relief for connecting cables

7 Basic circuit diagram



8 Installation

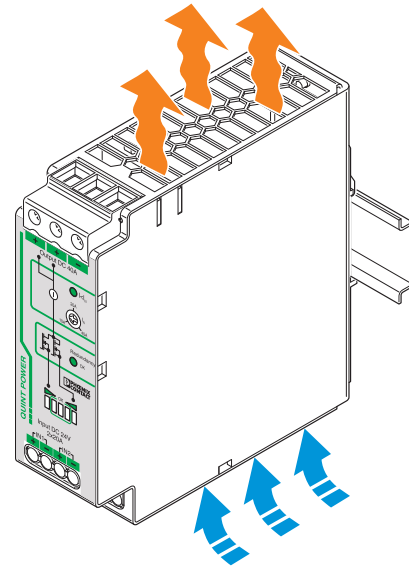

Figure 2 Convection



In order to ensure sufficient convection, we recommend a minimum vertical distance of 50 mm to the other modules. A lateral distance of 5 mm, and in the case of active components, that of 15 mm is necessary for proper functioning of the module. Depending on the ambient temperature and the load of the module, the housing can become very hot.



The module can be snapped onto all DIN rails according to EN 60715 and should be mounted in the normal mounting position (horizontal device orientation, connection terminal blocks on top and bottom).

9 Mounting position

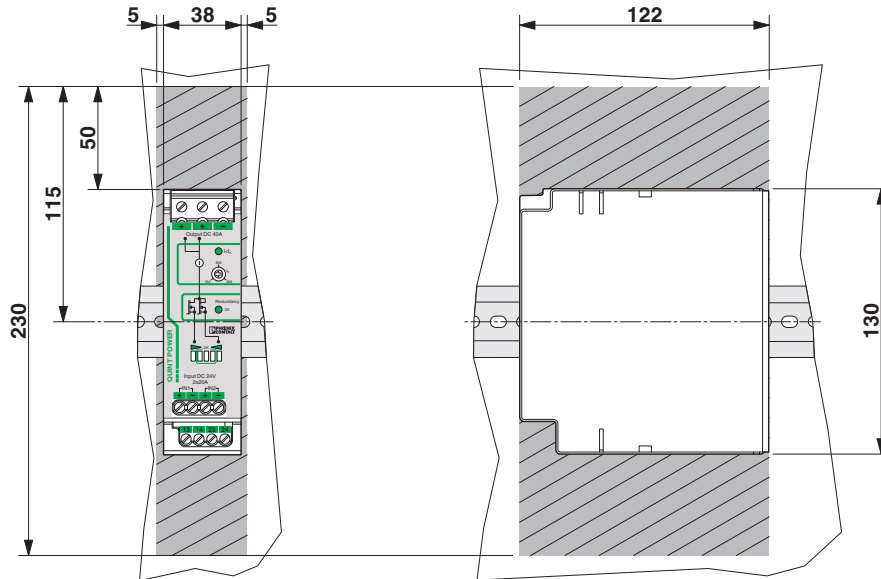

Figure 3 Installation dimensions

Possible mounting positions:

Normal mounting position, installation depth 125 mm (+ DIN rail) (delivery state)

Rotated mounting position, 270° Y-axis, installation depth: 41 mm (+ DIN rail)

10 Mounting on DIN rails

Assembly

Position the module with the DIN rail guide on the upper edge of the DIN rail, and snap it in with a downward motion.

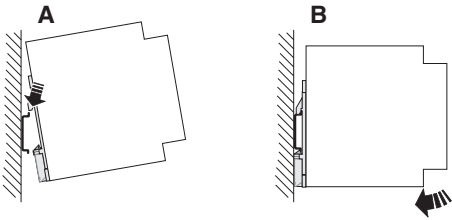

Figure 4 Assembly

Removal

Pull the snap lever open with the aid of a screwdriver and slide the module out at the lower edge of the DIN rail.

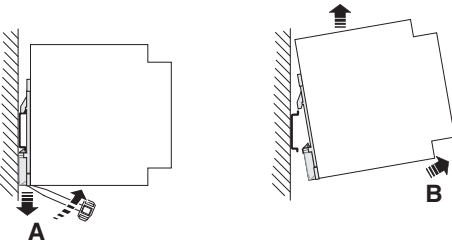

Figure 5 Removal

Rotated mounting position (270° Y-axis)

A rotated mounting position can be achieved by mounting the module onto the DIN rail at a 270° angle. Mount the DIN rail adapter (UTA 107/30) as shown in the figure. No additional assembly material is required. Mounting screws: Torx® T10 (0.8 Nm ... 0.9 Nm tightening torque).

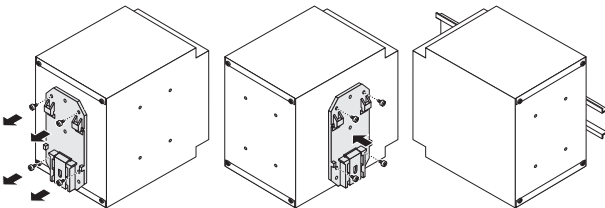

Figure 6 Rotated mounting position (270° Y-axis)



Other mounting positions are also possible. Always observe position-dependent derating.

11 Input

Connection of the input is made via connection terminal blocks "In1+" and "In2+".

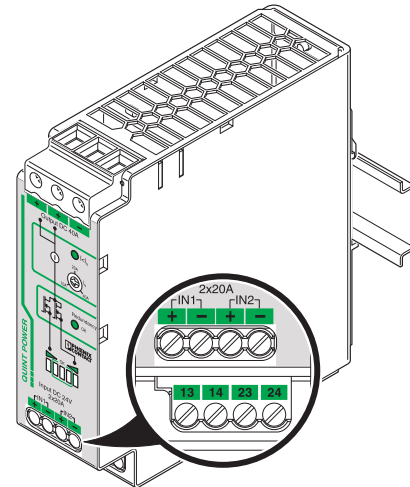

Figure 7 Input

Protection of the primary side

The maximum current for each input is 26 A. Therefore use a current-limited source (e. g., QUINT POWER) or a suitable fuse.

12 Output

Connection of the output takes place via the internally connected "+" terminals and the "-" terminal.

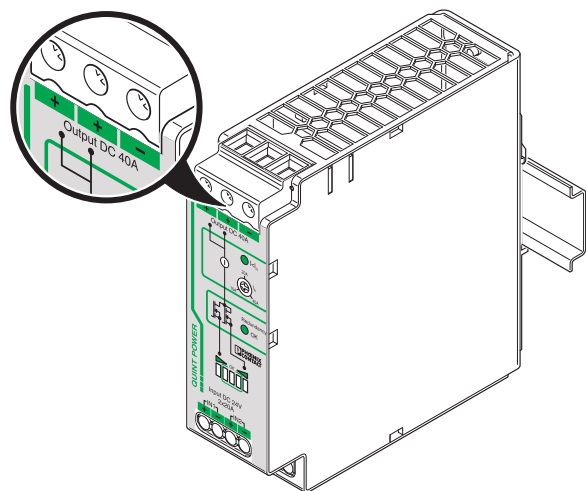

Figure 8 Output

13 Signaling

The "Redundancy OK" (13/14) and "ACB OK" (23/24) floating signal contacts are available for function monitoring.

In addition, the "Redundancy OK" and " $I < I_N$ " LEDs as well as the bar graph allow onsite function evaluation of the redundancy module.

To monitor the redundancy, the nominal current of the upstream power supply units can be set on the redundancy module using the rotary selection switch

The following table shows the possible states.

a)		b)		$I < I_N$	Redundancy OK	ACB OK	Description	
OK		OK		LED	LED	Relay 13/14		Relay 23/24
	or					closed	closed	Redundancy OK, load distribution OK
	or					closed	closed	Redundancy OK Load distribution OK by ACB however, power supply not optimally adjusted a) increase voltage at IN2 or decrease voltage at IN1 b) increase voltage at IN1 or decrease voltage at IN2
	or					closed	open	Redundancy OK No load distribution because power supply not adjusted a) increase voltage at IN2 or decrease voltage at IN1 b) increase voltage at IN1 or decrease voltage at IN2
X	or	X				open	X	No redundancy because $I > I_N$ Verify load current
	or					open	open	No redundancy because an input is not being supplied with power a) Check input IN2 and its connections b) Check input IN1 and its connections
	or					open	open	Short circuit at output of the redundancy module or Device is not being supplied with power
	or			X		open	X	If a red LED lights up permanently, the device must be checked by the manufacturer.

LED flashing
 LED on
 LED off
 X Not relevant

Figure 9 Signaling

13.1 "Redundancy OK" floating signal contact

The floating signal contact reports the loss of redundancy by opening.

The following causes are possible:

- The decoupled component is defective.
- At least one input voltage is too low or does not exist.
- If the load current is higher than the set threshold value of I_N , a single power supply unit can no longer sustain the load. This is reported after 4 seconds.

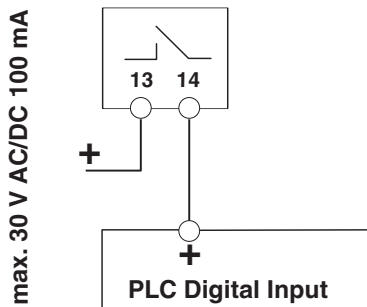

13.2 "ACB OK" floating signal contact

The floating signal contact opens and reports that the load current is not distributed symmetrically on both parallel connected power supply units.

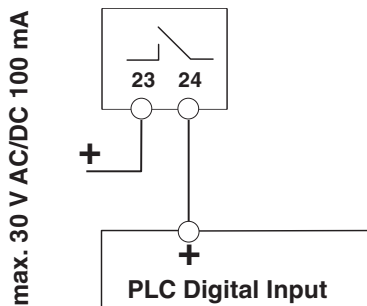

14 Function

The redundancy module decouples the outputs of two power supply units and ensures safe redundancy.

14.1 Input/output

Only one redundancy module is required for decoupling two power supply units 1 and 2 switched in parallel with nominal currents of up to 20 A.

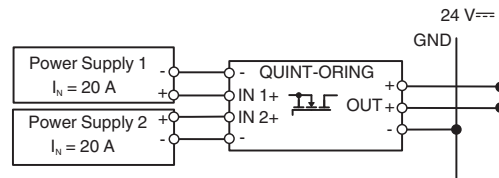

14.2 ACB technology

The service life of the redundantly operated power supply unit can be doubled by the Auto Current Balance (ACB) technology, which evenly loads both power supply units. The load current is automatically distributed symmetrically. Use connection cables of the same length and cross section.

14.3 Protection against static surge voltage

The IN 1 and IN 2 inputs are equipped with a protective circuit that is triggered in the event of static surge voltages >30 V. Two input voltages must be present that are independent of each other. Two-fold error safety against surge voltages can therefore be ensured in a system with QUINT POWER power supply units.

15 Derating

15.1 Temperature response

The active redundancy module can be operated with a maximum current of 2 x 26 A up to an ambient temperature up to +40 °C. In the case of ambient temperatures up to +60 °C, the device can be operated continually with the nominal current. In the case of ambient temperatures of more than +60 °C, the output power must be reduced by 2.5 % for each Kelvin increase of temperature. In the case of ambient temperatures of more than +70 °C or thermal overload, the device is not switched off. Reduce the output power enough to ensure protection of the device.

When using the QUINT POWER (20 A) power supply unit, the derating curve is maintained automatically.

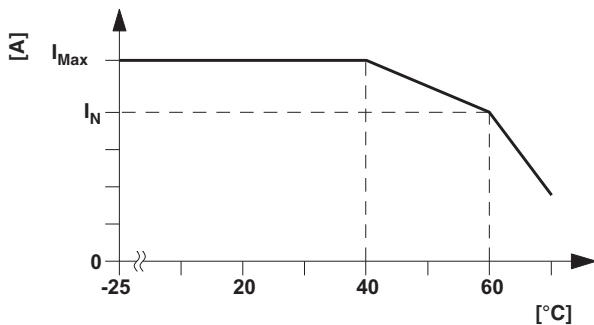

Figure 10 Derating diagram

15.2 Position-dependent derating

The redundancy module can be snapped onto all DIN rails according to EN 60715. It should be mounted horizontally in the normal mounting position (with the input terminals facing downward).

When installing in a different mounting position, derating should be adhered to.

The characteristic curve can be used to determine the maximal output power to be drawn for each ambient temperature for different mounting positions.

Normal mounting position

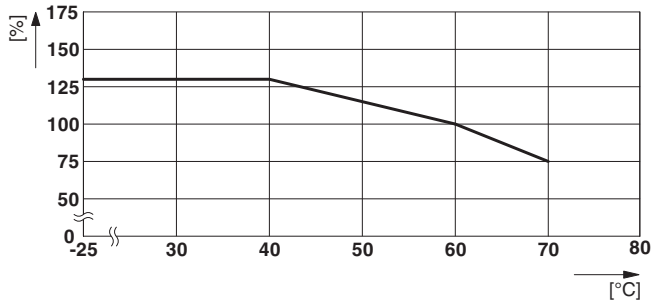
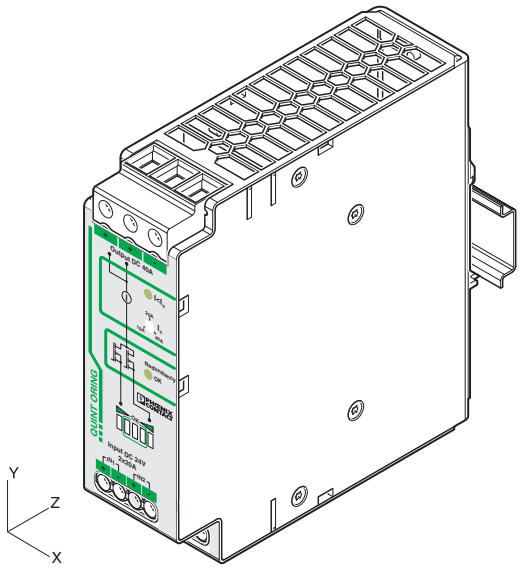

Rotated mounting position 90° X-axis

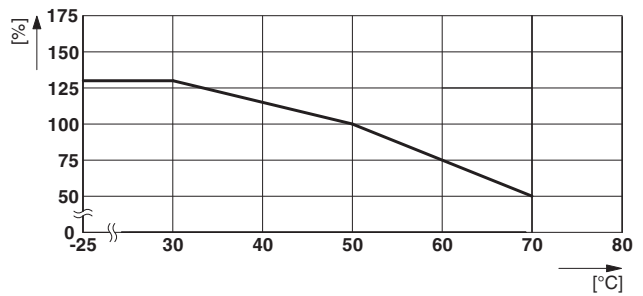
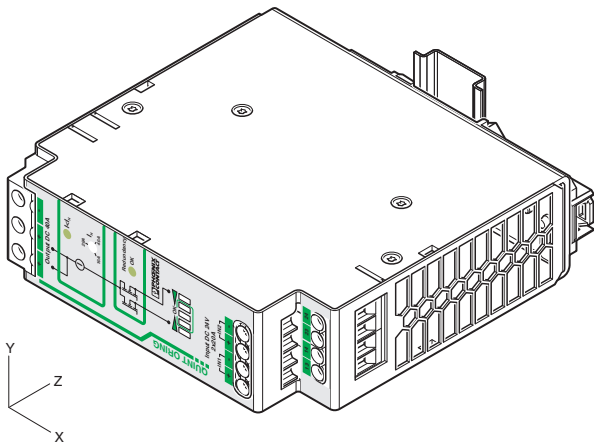

Rotated mounting position 180° X-axis

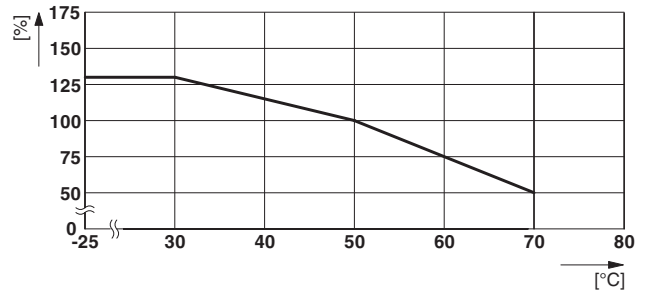
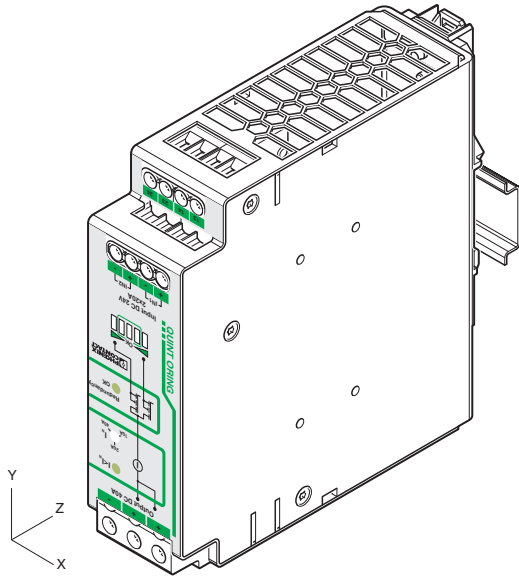

Rotated mounting position 270° X-axis

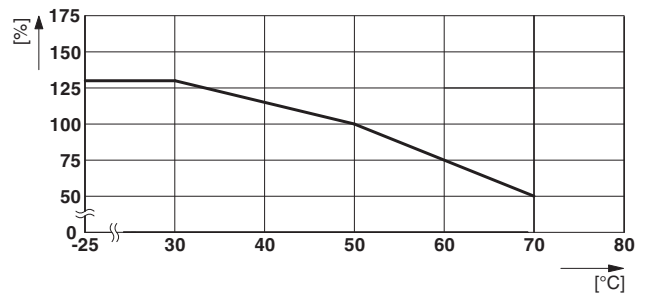
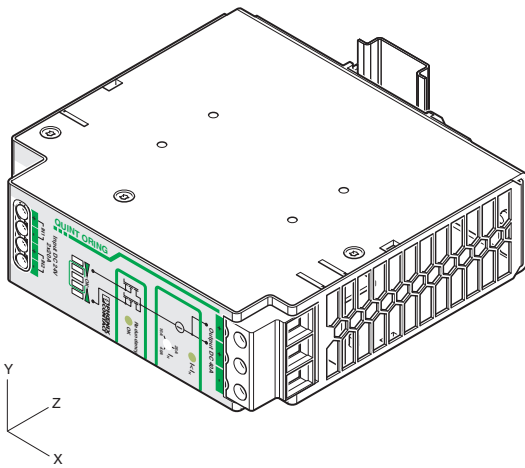

Rotated mounting position 90° Z-axis

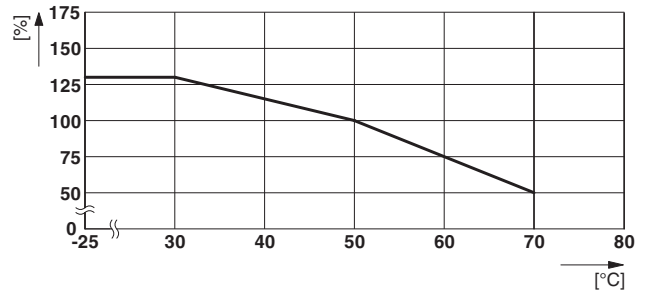
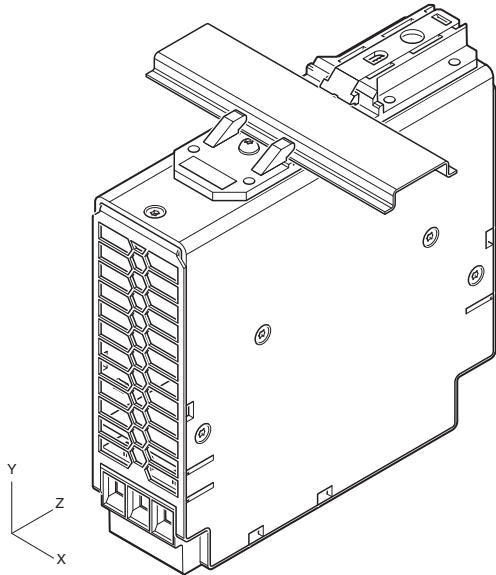

Rotated mounting position 270° Z-axis

