

## M422, Pt Temperature Sensor according to DIN EN 60751

Temperature range -70 °C to +500 °C, temporary up to +550 °C

- Excellent long term stability and low drift
- High accuracy and interchangeability
- High vibration and shock resistance
- Optimized for welding, brazing and crimping
- Ideal choice for your large volume applications

M-series RTDs are characterized by long-term stability and excellent precision over a wide temperature range. The M422 combines performance and high volume availability. The perfect choice for pyrolytic ovens, home appliance, HVAC industries, medical devices, industrial process monitoring and more. In principle, the products can also be used in automotive applications, in this case Heraeus will check upon the request of the customer, whether additional requirements can be met (e.g. IMDS, PPAP).

Nominal Resistance $R_0$ [ $\Omega$ ]	Tolerance Class	Order Number	Packaging
Pt100	F 0.1 (Class 1/3 B) F 0.15 (Class A) F 0.3 (Class B)	32208500 / 32208522 32208498 / 32208521 32208392 / 32208520	Plastic bag / Blister reel Plastic bag / Blister reel Plastic bag / Blister reel
Pt500	F 0.1 (Class 1/3 B) F 0.15 (Class A) F 0.3 (Class B)	32208502 32208501 / 32208524 32208414 / 32208523	Plastic bag Plastic bag / Blister reel Plastic bag / Blister reel
Pt1000	F 0.1 (Class 1/3 B) F 0.15 (Class A) F 0.3 (Class B)	32208537 32208503 / 32208527 32208499 / 32208526	Plastic bag Plastic bag / Blister reel Plastic bag / Blister reel

The measuring point for the nominal resistance is 8 mm from the end of the sensor body.

### Temperature Range of Tolerance Class

Tolerance Class F 0.1 (1/3 B)      0 °C to +150 °C  
 Tolerance Class F 0.15 (A)        -50 °C to +300 °C  
 Tolerance Class F 0.3 (B)         -70 °C to +500 °C  
 The specified tolerance classes refer to continuous operation.  
 Class F 0.3 also applies up to +550 °C for short periods.

### Temperature Coefficient

TCR = 3850 ppm/K

### Response Time

Water ( $v = 0.4$  m/s):                 $t_{0.5} = 0.07$  s  
     $t_{0.9} = 0.2$  s  
 Air ( $v = 2$  m/s):                      $t_{0.5} = 3.2$  s  
     $t_{0.9} = 11$  s

### Measuring Current

Pt100  $\Omega$ : 0.3 to 0.3 mA  
 Pt500  $\Omega$ : 0.1 to 0.7 mA  
 Pt1000  $\Omega$ : 0.1 to 0.3 mA  
 (self-heating has to be considered)

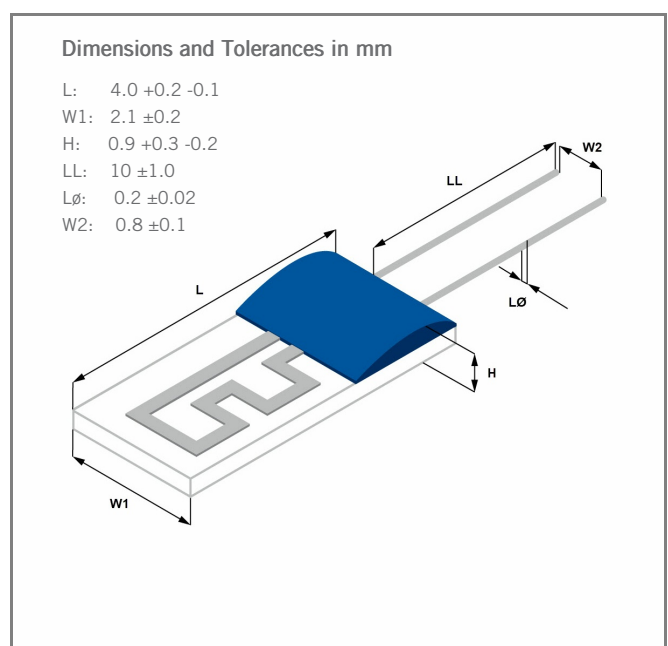

Image for illustration purposes only  
 Color, shape and forming of fixing drop may vary

## M422, Pt Temperature Sensor according to DIN EN 60751

Temperature range -70 °C to +500 °C, temporary up to +550 °C

### Long-Term Stability

The drift of the resistance value at 0 °C after a storage for 1000 hours in air at the declared upper temperature limit is not more than the tolerance value of the declared tolerance class according DIN EN 60751.

Typical drift of R(0 °C) is 0.04 % after 1000 hours at +500 °C.

### Self-Heating

0.3 K/mW at 0 °C

### Insulation Resistance

> 100 MΩ at 20 °C

> 2 MΩ at 500 °C

### Vibration Resistance

At least 40 g acceleration at 10 to 2000 Hz, depends on installation

### Shock Resistance

At least 100 g acceleration with 8 ms half sine wave, depends on installation

### Connection Technology

Welding, Crimping, Brazing

### Lead Type

Pt clad Ni-wire

### Tensile Strength of Leads

≥ 9N

### Packaging

Blister reel, Plastic bag

Alternative packaging forms on request.

### Storage Life

Min. 12 months (in original packaging)

### Note

Other tolerances, values of resistance and wire lengths are available on request.

Due to random sample measurements, a bending of connection wires may occur (called V-shape). This bending is batch-dependent and has no influence on the functionality of the platinum measuring resistor.

### California Proposition 65



## WARNING

WARNING: This product can expose you to chemicals including lead oxide, which is known to the State of California to cause cancer and birth defects or other reproductive harm, and including cobalt oxide, nickel and cobalt, which are known to the State of California to cause cancer.

For more information go to [www.p65warnings.ca.gov](http://www.p65warnings.ca.gov)



The information provided in this data sheet describes certain technical characteristics of the product, but shall not be qualified or construed as quality guarantee (Beschaffenheitsgarantie) in the meaning of sections 443 and 444 German Civil Code. The information provided in this data sheet regarding measurement values (including, but not limited to, response time, long-term stability, vibration and shock resistance, insulation resistance and self-heating) are average values that have been obtained under laboratory conditions in tests of large numbers of the product. Product results or measurements achieved by customer or any other person in any production, test, or other environment may vary depending on the specific conditions of use.

The customer is solely responsible to determine whether the product is suited for the customer's intended use; in this respect Heraeus cannot assume any liability. The sale of any products by Heraeus is exclusively subject to the General Terms of Sale and Delivery of Heraeus in their current version at the time of purchase, which is available under [www.heraeus.com/gtc](http://www.heraeus.com/gtc) or may be furnished upon request. This data sheet is subject to changes without prior notice.

Heraeus Nexensos GmbH, Reinhard-Heraeus-Ring 23, 63801 Kleinostheim, Germany

Heraeus Nexensos GmbH, Germany  
 Web: [www.heraeus-nexensos.com](http://www.heraeus-nexensos.com)  
 Contact: [nexensos.america@heraeus.com](mailto:nexensos.america@heraeus.com)

Document: 20002221052 | Part 001 | Version 01 | Status: 09/2021

Page 2 of 2