

引き出し方向
PULL OUT DIRECTION

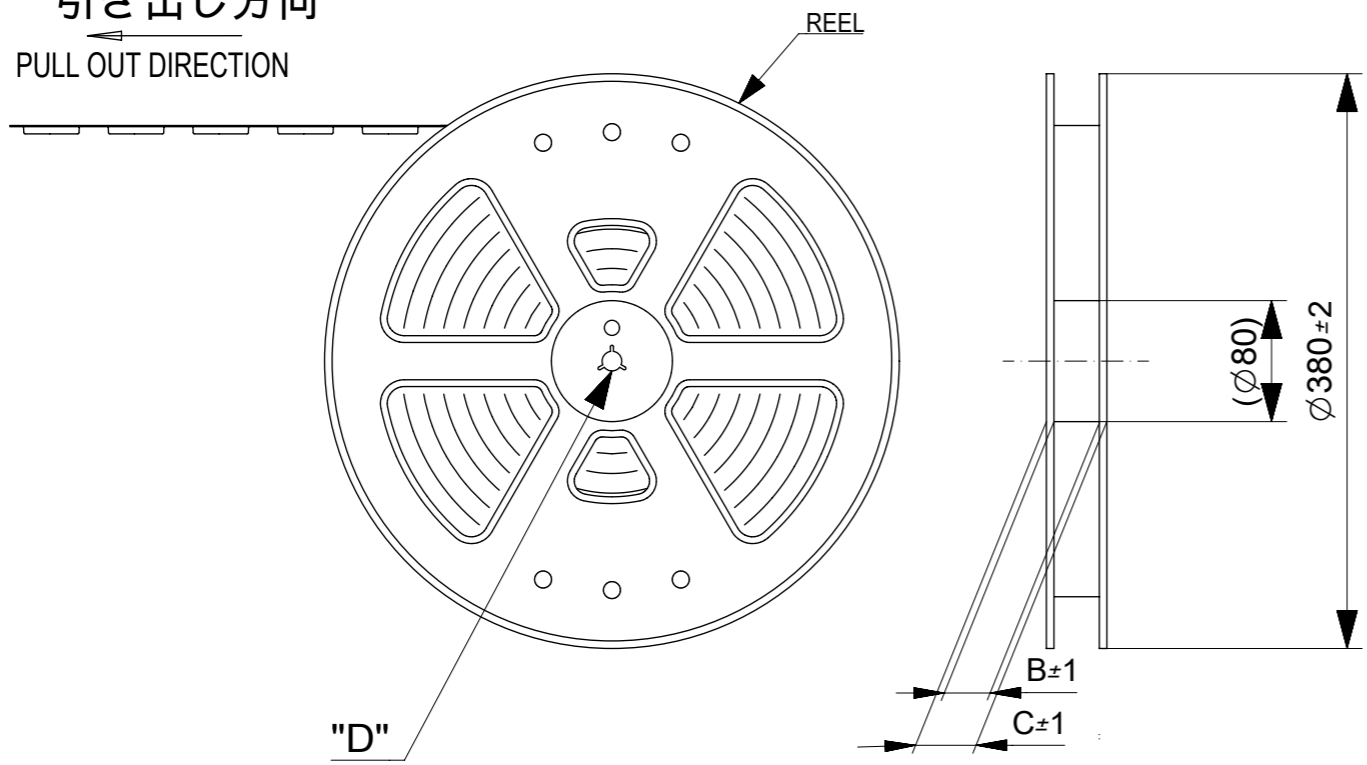

注記 NOTES

- 製品詳細寸法については製品単体図面を参照下さい。
RE DETAILED DIMENSION, SEE PRODUCT DRAWING.
- 梱包数量：7000個 / リール
NUMBER OF CONNECTORS : 7000 PCS/REEL.
- リードテープ長さ LEAD TAPE LENGTH.

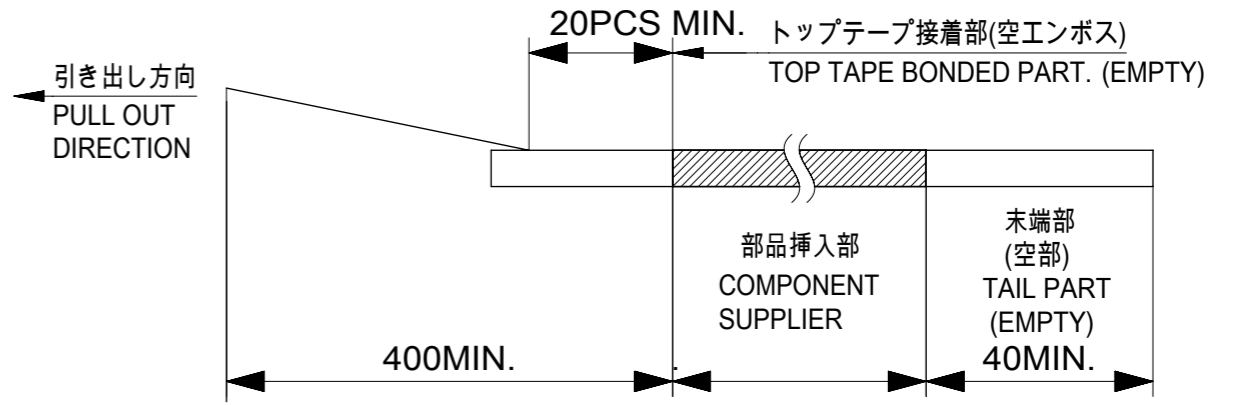

- カバーテープの剥離強度については、IEC60286-3に準拠。
COVER TAPE PEEL FORCE IS DEFINED BY IEC60286-3.
- 材料 MATERIAL
キャリアテープ(CARRIER TAPE) : ポリスチレン(POLYSTYRENE)
トップテープ(TOP TAPE) : PET, OTHER
リール(REEL) : ポリスチレン(PS) <リサイクル材を含む>
POLYSTYRENE(PS) < RECYCLE MATERIAL CONTAINED >

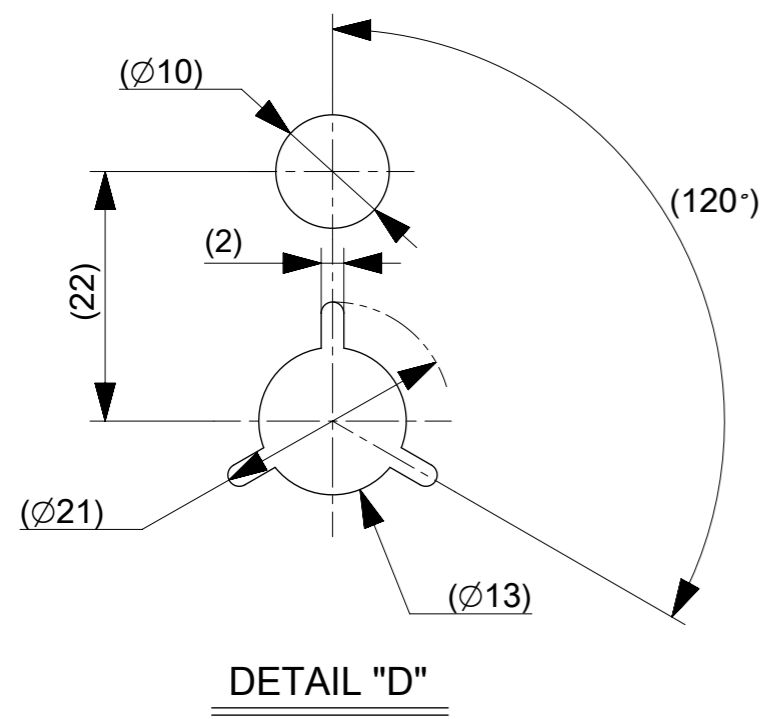

DETAIL "D"

THIS DRAWING CONTAINS INFORMATION THAT IS PROPRIETARY TO MOLEX ELECTRONIC TECHNOLOGIES, LLC AND SHOULD NOT BE USED WITHOUT WRITTEN PERMISSION										
REVISED	EC NO. 169127	2017/12/06	GENERAL TOLERANCES (UNLESS SPECIFIED)		DIMENSION UNITS	SCALE	molex [®]			
	DRWN: GB	2017/12/06	ANGULAR TOL ± 3.0 °		mm	NTS				
	CHK'D: TNAKAGAWA01	2017/12/06	4 PLACES	± 0.03	DRWN BY	DATE	0.4 BB CONN. HGT=0.8 PLUG ASSY			
	REVISION: C	2017/12/14	3 PLACES	± 0.03	YSHIBATA	2016/12/07				
	DATE: 2015/12/14		2 PLACES	± 0.05	CHK'D BY	DATE	PRODUCT CUSTOMER DRAWING			
		1 PLACE	± 0.1	KTAKAHASHI	2016/12/26					
		0 PLACES	± 0.2	APPR BY	DATE	SERIES MATERIAL NUMBER CUSTOMER				
		DRAFT WHERE APPLICABLE MUST REMAIN WITHIN DIMENSIONS		MSASAO	2016/12/26				503776	SEE CHART
				DRAWING SIZE	THIRD ANGLE PROJECTION	DOCUMENT NUMBER		DOC TYPE	DOC PART	SHEET NUMBER
				A3		5037760001		PSD	000	1 OF 3

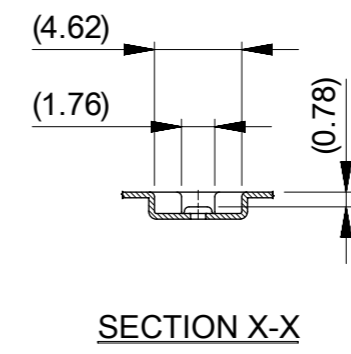
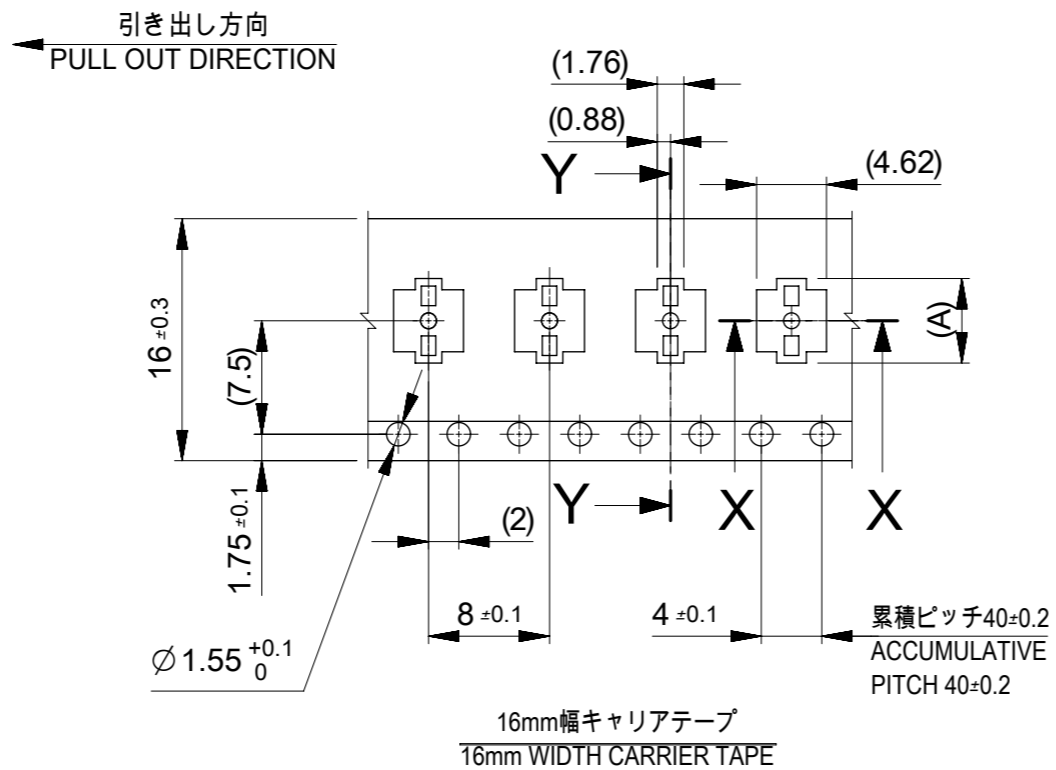
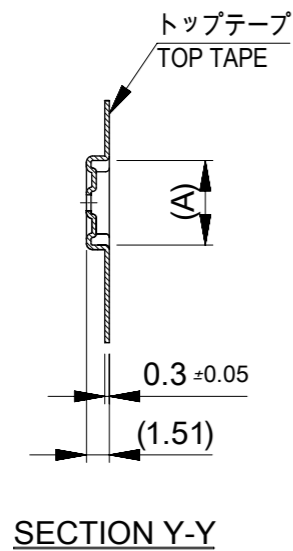

16	21.4	17.4	6.39	503776-2420	24
			5.59	503776-2020	20
			4.79	503776-1620	16
			3.59	503776-1020	10
キャリアテープ幅 CARRIER TAPE WIDTH		C	B	(A)	EMBOSSED PACKAGE 極数 CIRCUITS
			オーダー番号 ORDER No.		
			CONNECTOR SERIES NO.:503776-**09		

THIS DRAWING CONTAINS INFORMATION THAT IS PROPRIETARY TO MOLEX ELECTRONIC TECHNOLOGIES, LLC AND SHOULD NOT BE USED WITHOUT WRITTEN PERMISSION

EC NO: 169127 DRWN: GB CHK'D: TNAKAGAWA01 APPR: MSASAO REV:	2017/12/06	2017/12/06	GENERAL TOLERANCES (UNLESS SPECIFIED)		DIMENSION UNITS	SCALE				
			ANGULAR TOL ± 3.0 °		mm	NTS				
	4 PLACES	± 0.03	YSHIBATA		DATE		0.4 BB CONN. HGT=0.8 PLUG ASSY			
	3 PLACES	± 0.03	KTAKAHASHI		2016/12/07					
	2 PLACES	± 0.05	MSASAO		DATE		PRODUCT CUSTOMER DRAWING			
	1 PLACE	± 0.1	MSASAO		2016/12/26					
0 PLACES	± 0.2	DRAWING SIZE		THIRD ANGLE PROJECTION		SERIES	MATERIAL NUMBER	CUSTOMER		
DRAFT WHERE APPLICABLE MUST REMAIN WITHIN DIMENSIONS		A3	A3		A3		503776	SEE CHART	GENERAL	
						DOCUMENT NUMBER		DOC TYPE	DOC PART	SHEET NUMBER
						5037760001		PSD	000	2 OF 3

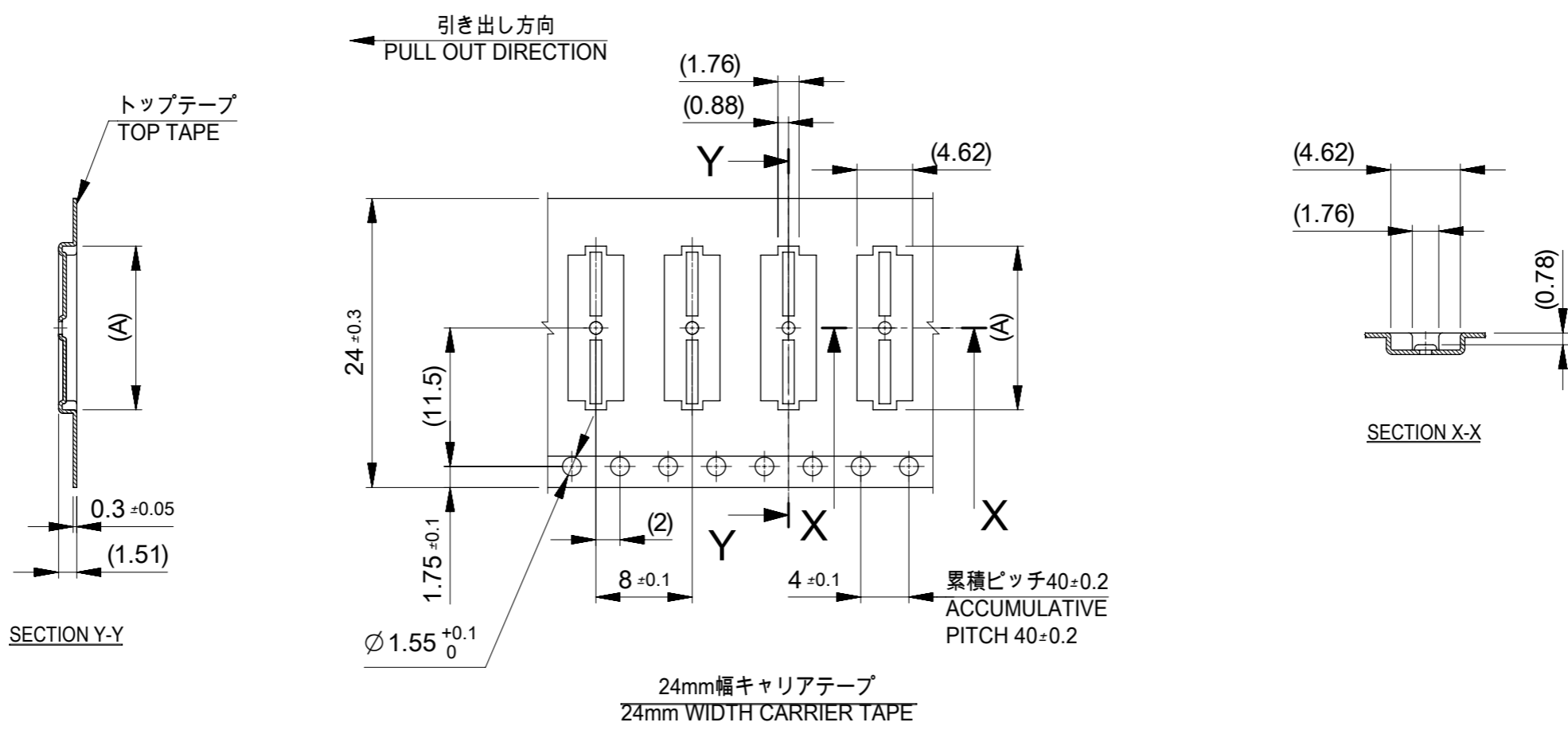

24	29.4	25.4	13.59	503776-6020	60
			11.59	503776-5020	50
			9.59	503776-4020	40
			8.39	503776-3420	34
			7.59	503776-3020	30
キャリアテープ幅 CARRIER TAPE WIDTH	C	B	(A)	EMBOSSED PACKAGE	極数
				オーダー番号 ORDER No.	CIRCUITS
				CONNECTOR SERIES NO.:503776-**09	

THIS DRAWING CONTAINS INFORMATION THAT IS PROPRIETARY TO MOLEX ELECTRONIC TECHNOLOGIES, LLC AND SHOULD NOT BE USED WITHOUT WRITTEN PERMISSION

EC NO: 169127 DRWN: GB CHK'D: TNAKAGAWA01 APPR: MSASAO REV:	2017/12/06 2017/12/06 2017/12/06	GENERAL TOLERANCES (UNLESS SPECIFIED) ANGULAR TOL ± 3.0 ° 4 PLACES ± 0.03 3 PLACES ± 0.03 2 PLACES ± 0.05 1 PLACE ± 0.1 0 PLACES ± 0.2	DIMENSION UNITS: mm SCALE: NTS		
	DRWN BY: YSHIBATA DATE: 2016/12/07	CHK'D BY: KTAKAHASHI DATE: 2016/12/26	DRWN BY: MSASAO DATE: 2016/12/26		0.4 BB CONN. HGT=0.8 PLUG ASSY
	DRAFT WHERE APPLICABLE MUST REMAIN WITHIN DIMENSIONS				
	PRODUCT CUSTOMER DRAWING				SERIES: 503776 MATERIAL NUMBER: SEE CHART CUSTOMER: GENERAL
	DOCUMENT NUMBER: 5037760001				DOC TYPE: PSD DOC PART: 000 SHEET NUMBER: 3 OF 3

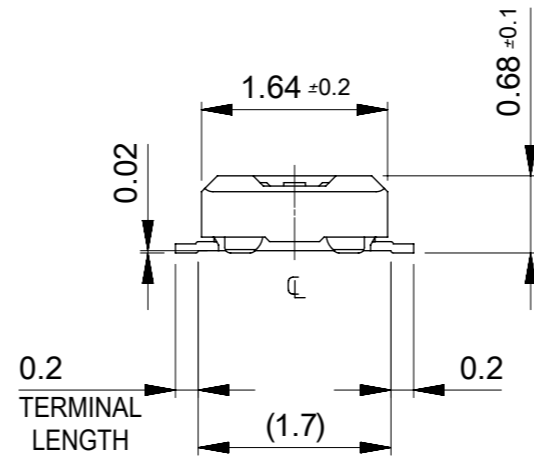
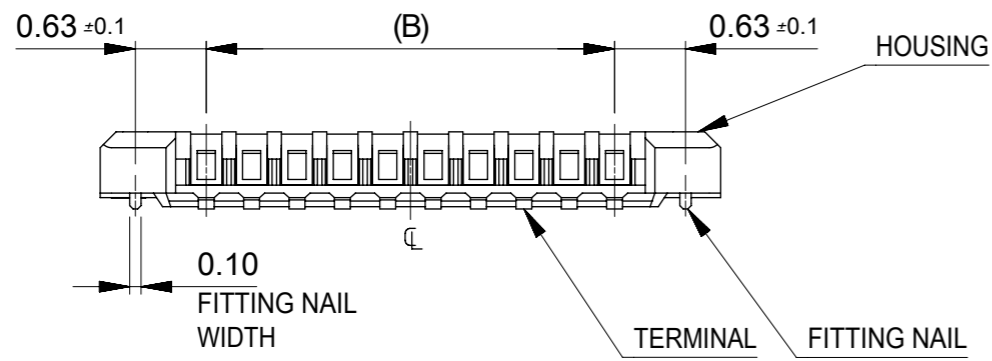
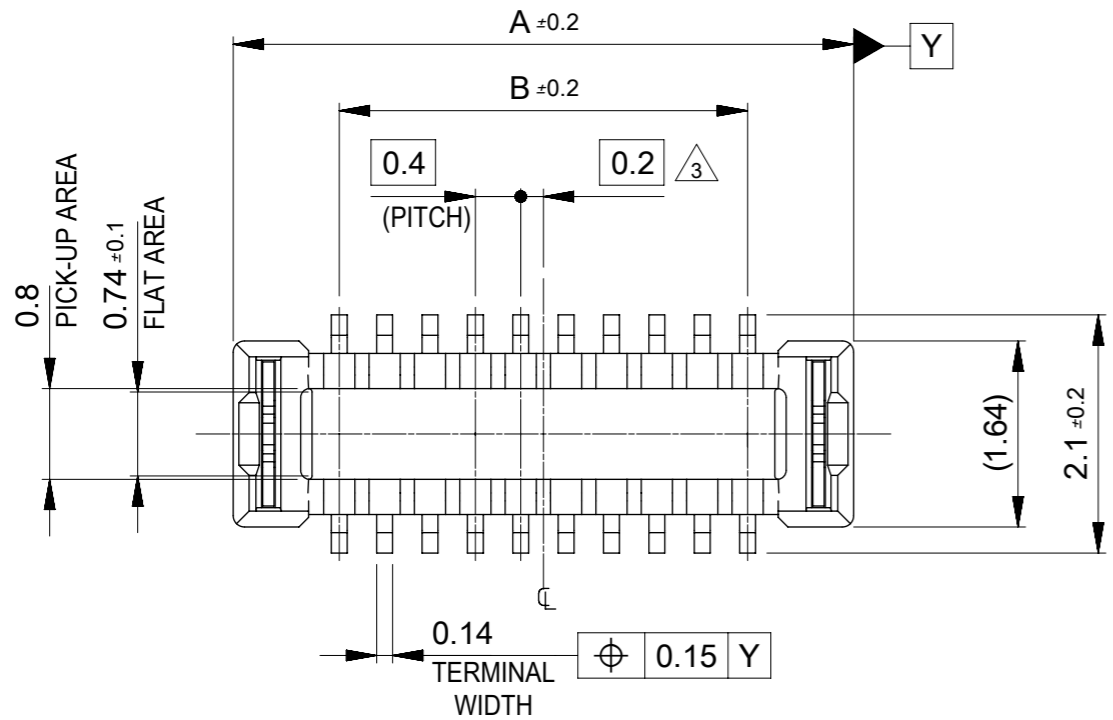

注記 NOTES

1. 使用材料 MATERIAL

ハウジング:液晶ポリマー(LCP) UL94V-0(黒)
 HOUSING : LIQUID CRYSTAL POLYMER UL94V-0 (COLOR : BLACK)
 ターミナル : 銅合金
 TERMINAL : COPPER ALLOY
 金具 : 銅合金
 FITTING NAIL : COPPER ALLOY

2. メッキ仕様 PLATING

ターミナル TERMINAL
 金メッキ
 GOLD
 下地メッキ : ニッケルメッキ
 UNDER PLATING : NICKEL
 ※コンタクト部とテール部はニッケルメッキによって分断されている金メッキです。
 DIVIDE INTO PARTS THE GOLD PLATING OF THE CONTACT AND THE TAIL PART BY THE NICKEL PLATING.

金具 FITTING NAIL

錫メッキ
 Tin PLATING
 下地メッキ : ニッケルメッキ
 UNDER PLATING : NICKEL

△3. (全極数/2)=偶数の場合に適用。
 APPLY FOR (CIRCUIT/2)=EVEN.

4. 嵌合相手 : 503772 シリーズ
 MATE WITH : 503772 SERIES.

5. テール及び金具の平坦度は、0.08以下。60極は0.1以下。
 TAIL AND FITTING NAIL COPLANARITY TO BE 0.08 MAXIMUM.
 TAIL AND FITTING NAIL COPLANARITY WITH 60ckt TO BE 0.1 MAXIMUM.

11.6	13.47	503776-6020	60
9.6	11.47	503776-5020	50
7.6	9.47	503776-4020	40
6.4	8.27	503776-3420	34
5.6	7.47	503776-3020	30
4.4	6.27	503776-2420	24
3.6	5.47	503776-2020	20
2.8	4.67	503776-1620	16
1.6	3.47	503776-1020	10
B	A	EMBOSSED PACKAGE	
		オーダー番号 ORDER No.	極数 CIRCUITS
		CONNECTOR SERIES No. : 503776-**09	

THIS DRAWING CONTAINS INFORMATION THAT IS PROPRIETARY TO MOLEX ELECTRONIC TECHNOLOGIES, LLC AND SHOULD NOT BE USED WITHOUT WRITTEN PERMISSION

REVISED EC NO: 169127 DRWN: GB CHK'D: TNAKAGAWA01 APPR: MSASAO	GENERAL TOLERANCES (UNLESS SPECIFIED)		DIMENSION UNITS	SCALE
	ANGULAR TOL ± 3.0 °		mm	15:1
	4 PLACES	± 0.03	DRWN BY	DATE
	3 PLACES	± 0.03	YSHIBATA	2016/12/07
	2 PLACES	± 0.05	CHK'D BY	DATE
	1 PLACE	± 0.1	KTAKAHASHI	2016/12/26
	0 PLACES	± 0.2	APPR BY	DATE
			MSASAO	2016/12/26
DRAFT WHERE APPLICABLE MUST REMAIN WITHIN DIMENSIONS		DRAWING SIZE	THIRD ANGLE PROJECTION	
		A3		

molex

0.4 BB CONN. HGT=0.8 W=2.5 PLUG ASSY

PRODUCT CUSTOMER DRAWING

SERIES	MATERIAL NUMBER	CUSTOMER	
503776	SEE TABLE	GENERAL	
DOCUMENT NUMBER		DOC TYPE	DOC PART SHEET NUMBER
5037761001		PSD	000 1 OF 2

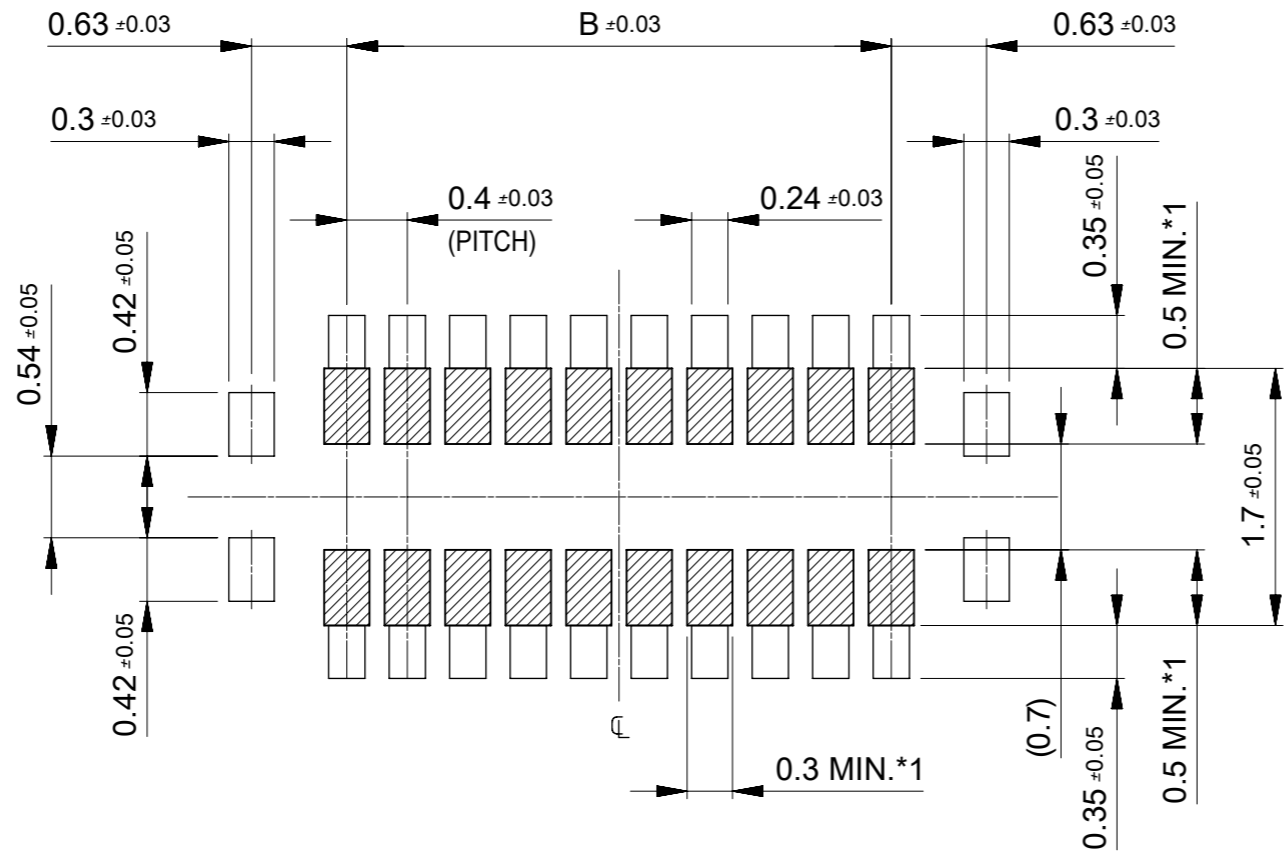

RECOMMENDED P.W. BOARD
PATTERN LAYOUT

- *1 パターン引き回し、および半田禁止エリア
(当該箇所においては、これと接する回路以外の配線を禁止する。
また、接する回路を配線する場合はレジストを施し、この部分に
半田は無きこととする。)
- *1 PROHIBITED AREA OF PATTERN WIRING AND SOLDER.
(FOR EACH AREA, THE WIRING THAT TOUCHES ON THE SOLDER
CAN BE ATTACHED, THEN COVERED WITH A FILM TO KEEP SOLDER OUT.)

THIS DRAWING CONTAINS INFORMATION THAT IS PROPRIETARY TO MOLEX ELECTRONIC TECHNOLOGIES, LLC AND SHOULD NOT BE USED WITHOUT WRITTEN PERMISSION

EC NO: 169127 DRWN: GB CHK'D: TNAKAGAWA01 APPR: MSASAO REV:	2017/12/06 2017/12/06 2017/12/06	GENERAL TOLERANCES (UNLESS SPECIFIED) ANGULAR TOL ± 3.0 ° 4 PLACES ± 0.03 3 PLACES ± 0.03 2 PLACES ± 0.05 1 PLACE ± 0.1 0 PLACES ± 0.2 DRAFT WHERE APPLICABLE MUST REMAIN WITHIN DIMENSIONS	DIMENSION UNITS mm	SCALE 20:1					
	DRWN BY YSHIBATA		DATE 2016/12/07	0.4 BB CONN. HGT=0.8 W=2.5 PLUG ASSY					
	CHK'D BY KTAKAHASHI		DATE 2016/12/26						
	APPR BY MSASAO		DATE 2016/12/26	PRODUCT CUSTOMER DRAWING			SERIES 503776	MATERIAL NUMBER SEE TABLE	CUSTOMER GENERAL
	DRAWING SIZE A3		THIRD ANGLE PROJECTION 	DOCUMENT NUMBER 5037761001			DOC TYPE PSD	DOC PART 000	SHEET NUMBER 2 OF 2
	C		REV						