

viewmate ^x

5

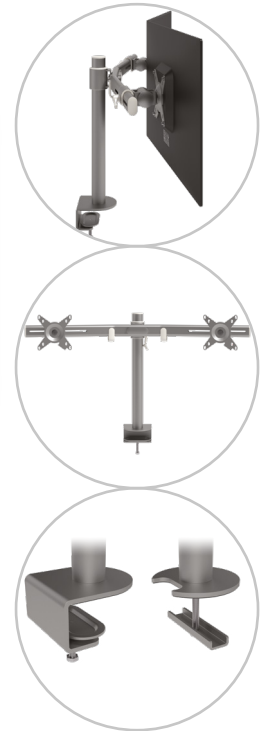
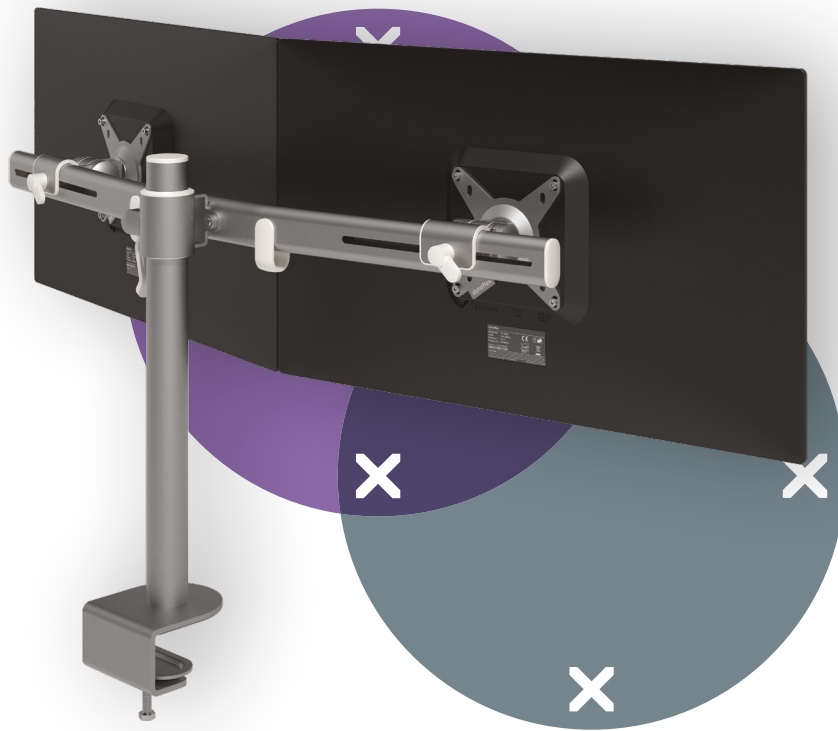

52.642

Viewmate monitor arm - desk 642

This dual monitor arm combines strength, practicality and usability in one package. The clamp lever lets you adjust the height of your monitors with the greatest of ease. With cable management on the crossbar and pole, this product offers a practical and user-friendly way to achieve a great and affordable dual monitor set-up.

- Easy to adjust in height using a clamp lever
- Static height adjustment range of 295 mm (11,6")
- Fixed depth
- Fitted with cable clips and cable loop ties to guide cables tidily
- Main components made of steel
- VESA MIS-D 75 x 75/100 x 100 mm compatible
- Monitor: tilt +90°/-90°, rotate 360°
- Arm: swivel 360°
- Weight capacity max. 15 kg (33 lb) per monitor
- Monitor size limit: width 640 mm (25,2") - height 712 mm (28,0")
- Comes with a desk clamp mount and bolt-through desk mount
- Suitable for a desktop thickness of 5 up to 40 mm (0,2" - 1,6") (clamp) or 50 mm (2,0") (bolt through)

dataflex^x

feeling at work

viewmate ^x

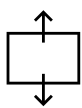
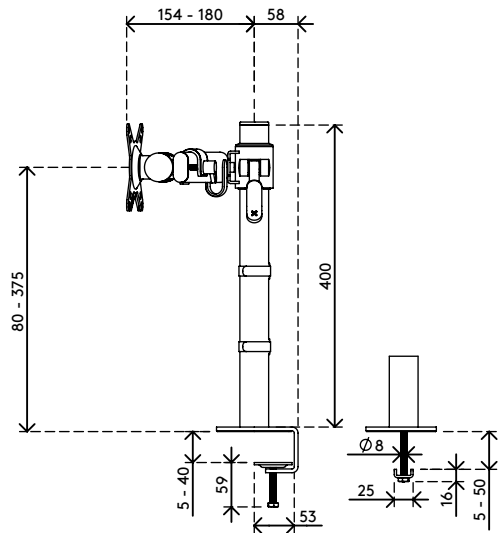
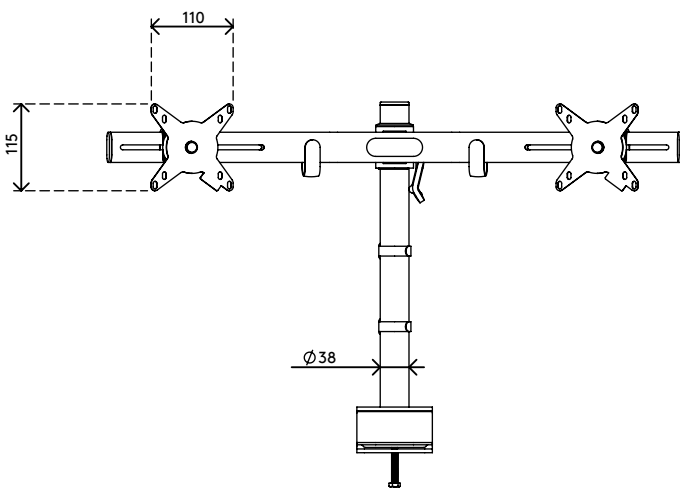
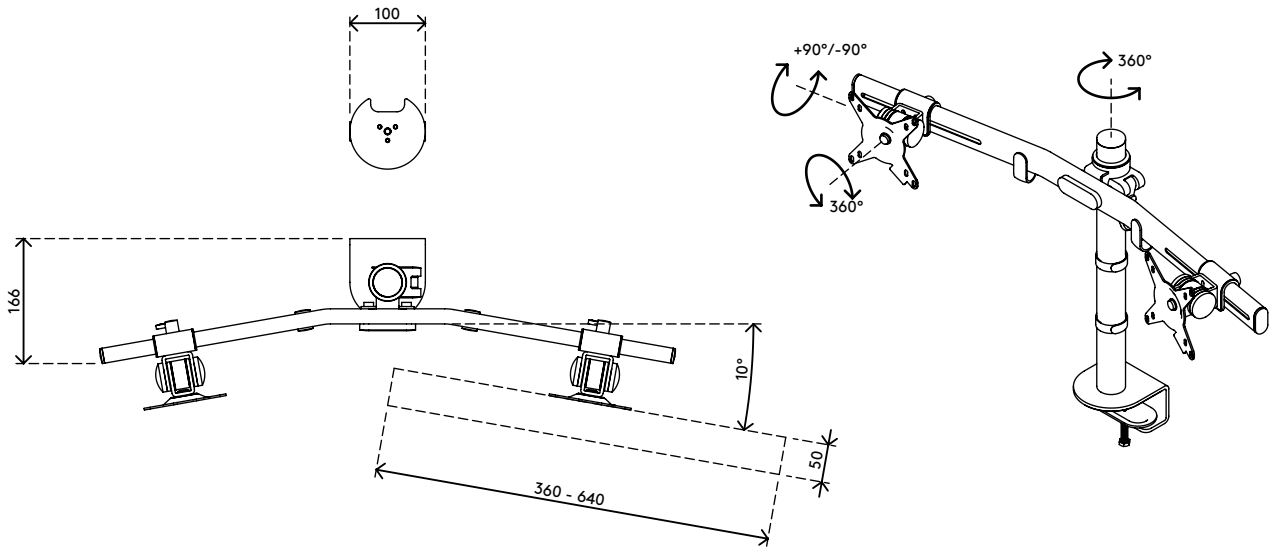

295 mm (11,6")



+90°/-90°



360°



640 mm (25,2")



713 mm (28,1")



75 x 75/100 x 100



(2x) 15 kg (33 lb)

Viewmate monitor arm - desk 642

2019/06/20

52.642

730 x 170 x 111 mm

1 pcs

silver

4,5 kg

805410526429