

SIZE	Part Number	Packing
25	8655MH2501LF	in bulk:Qty:60
	8655MH2511LF	individual set 50 sets/carton

NOTE:RoHS INFORMATIONS

- The LF product meets European union Directives and other country regulations as described in GS-22-009
- The product is not intended to be exposed to a manufacturing solder process
- Packaging spec:see GS-14-920

NOTES:for all sizes

Material and finish: Zinc die-cast nickel plated

Cable strain relief: Zinc die-cast

Jackscrew: Steel,nickel plated UNC 4.40

Temperature range: -55°C to +125°C

Attenuation factor: >40 dB between 10 MHz

Other size details: see on next pages.

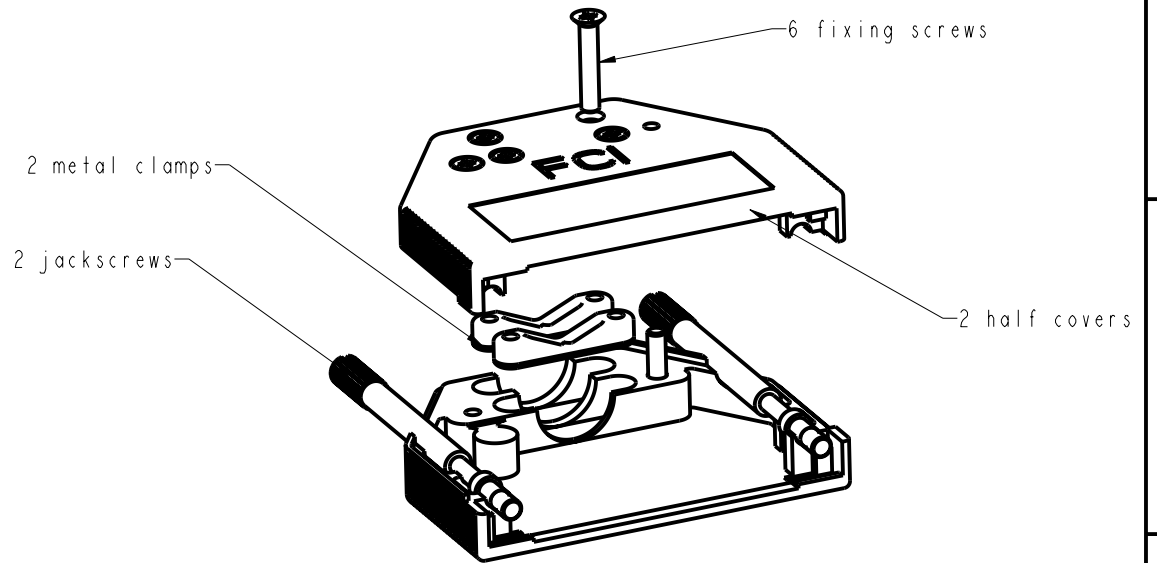
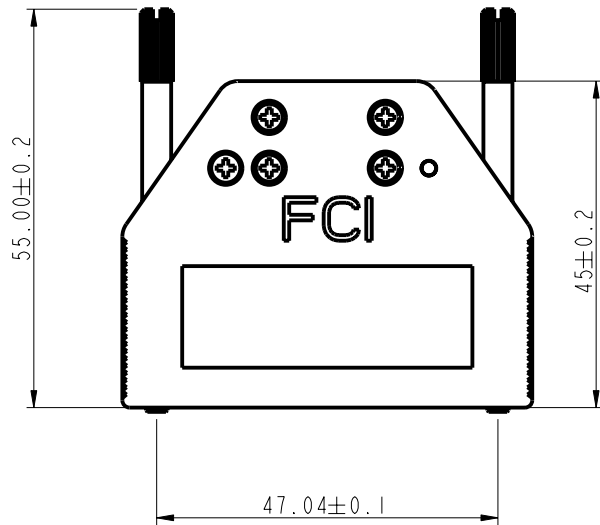
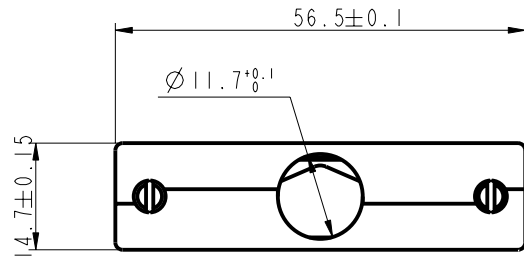

Copyright FCI

www.fciconnect.com				surface ISO 1302	tolerance std ISO 406 ISO 1101	projection mm	mm			
				TOLERANCES UNLESS OTHERWISE SPECIFIED		↔				
Dr	M PESSON	2008/02/19	ANGULAR	0.X	±0.3	size A3	Scale 1:1	ECN LS08-0058		
Eng	M PESSON	2008/02/19	LINEAR	0.XX	±0.1					
Chr	P LEGARE	2008/02/19	0° ±2°	0.XXX	±0.05					
Appr	P LEGARE	2008/02/19	Product family			Spec ref				
rev	ecn no	dr	date	FCI			title STRAIGHT METAL HOODS WITH 2 METAL CLAMPS		dwg no C-8655-1685	Rev. A
A	LS08-0058	MPE	2008/02/21				catalog no		CUSTOMER	sheet 1 of 4

REV F - 2006-04-17

SIZE	Part Number	Packing
09	8655MH0901LF	in bulk:Qty:80
	8655MH0911LF	individual set 50 sets /carton

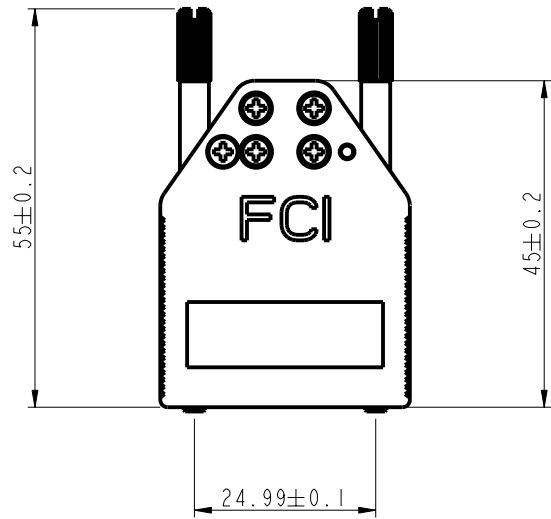
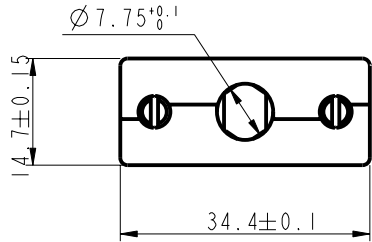

SIZE	Part Number	Packing
15	8655MH1501LF	in bulk:Qty:80
	8655MH1511LF	individual set 50 sets/carton

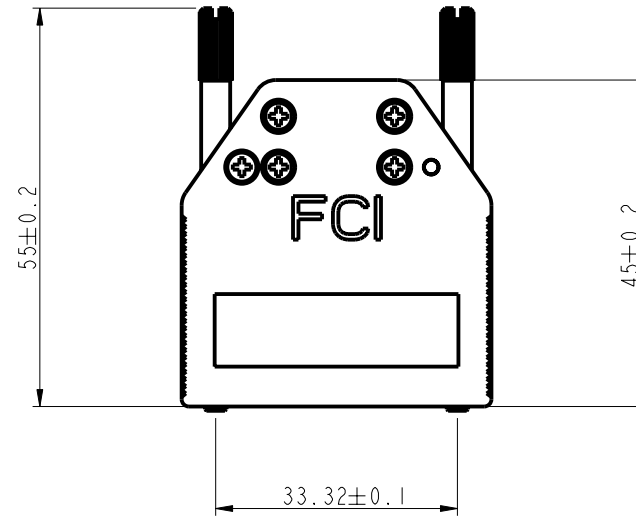
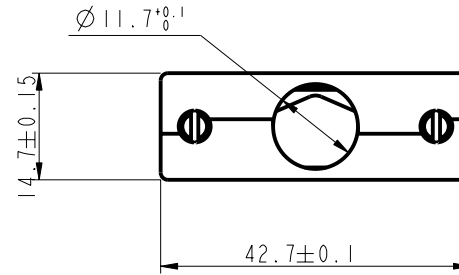

Copyright FCI.

REV 1 - 2006-04-17

www.fciconnect.com			surface - <input checked="" type="checkbox"/>	tolerance std	projection	mm
			ISO 1302	ISO 406 ISO 1101		
			TOLERANCES UNLESS OTHERWISE SPECIFIED			
Dr	M PESSON	2008/02/19	ANGULAR	0.X ±0.3	size	Scale
Eng	M PESSON	2008/02/19	LINEAR	0.XX ±0.1	A3	1:1
Chr	P LEGARE	2008/02/19		0° ±2°	0.XXX ±0.05	ECN
Appr	P LEGARE	2008/02/19	Product family	D-SUB	Spec ref	
	TITLE STRAIGHT METAL HOODS			dwg no	C-8655-1685	Rev.
	WITH 2 METAL CLAMPS					A
	catalog no			CUSTOMER	sheet 2 of 4	

SIZE	Part Number	Packing
37	8655MH3701LF	in bulk:Qty:40
	8655MH3711LF	individual set 50 sets /carton

$\varnothing 11.7^{+0.1}_0$

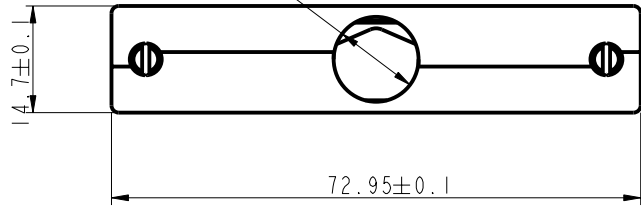

SIZE	Part Number	Packing
50	8655MH5001LF	in bulk:Qty:40
	8655MH5011LF	individual set 50 sets /carton

$\varnothing 14^{+0.1}_0$

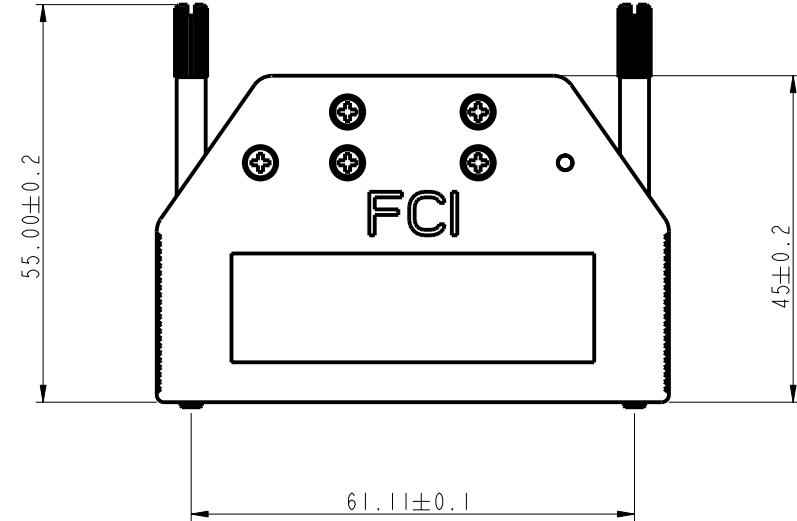
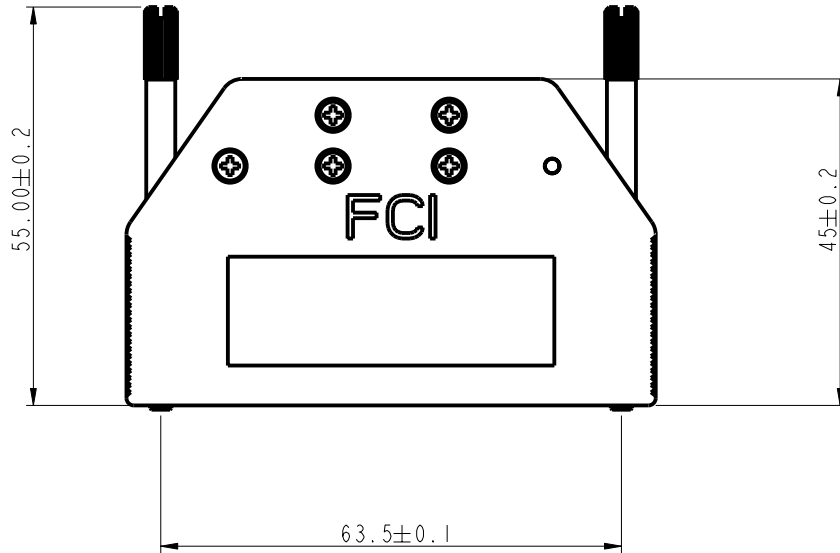
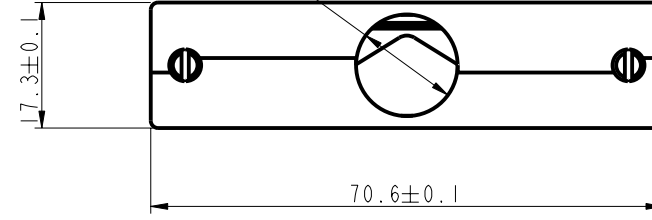

Copyright FCI

www.fciconnect.com			surface - <input checked="" type="checkbox"/>	tolerance std	projection	mm
			ISO 1302	ISO 406 ISO 1101		
			TOLERANCES UNLESS OTHERWISE SPECIFIED			
Dr	M PESSON	2008/02/19	ANGULAR	0.X	±0.3	size A3
Eng	M PESSON	2008/02/19	LINEAR	0.XX	±0.1	Scale 1:1
Chr	P LEGARE	2008/02/19	0° ±2°	0.XXX	±0.05	ECN LS08-0058
Appr	P LEGARE	2008/02/19	Product family	D-SUB		Spec ref
	TITLE STRAIGHT METAL HOODS			DWG no C-8655-1685		Rev. A
	WITH 2 METAL CLAMPS			CUSTOMER		sheet 3 of 4
	catalog no					

REV F - 2006-04-17

## CABLING INSTRUCTIONS

1- Strip the cable and solder or crimp the wires

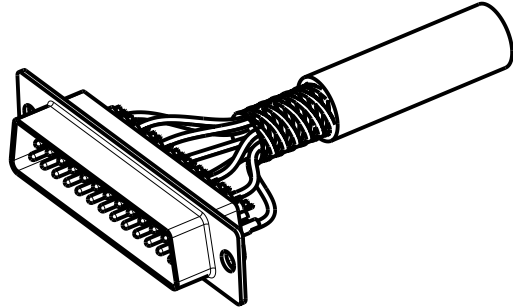

SCALE 3:2

2- Put the connector into a half hood and tighten the jacket with a metal clamp

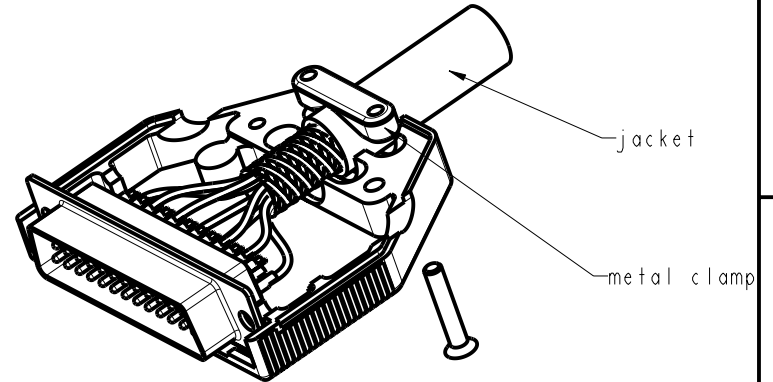

SCALE 3:2

3- To get the electrical continuity between the cable outer conductor and the hood tighten the outer conductor with the other metal clamp as shown

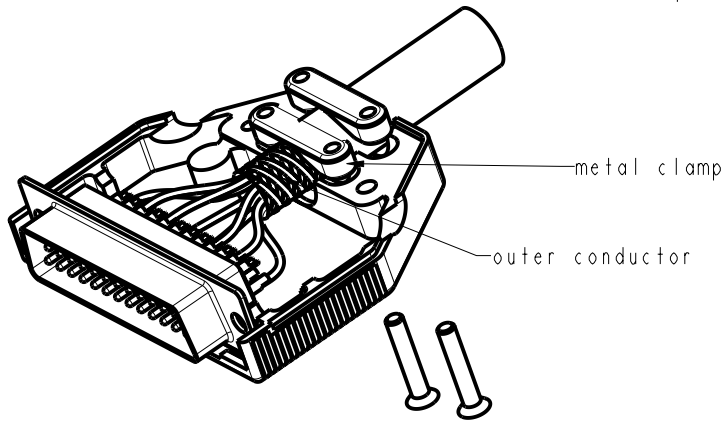

SCALE 3:2

4- Mount the jackscrews, the other half hood and tighten with 2 screws

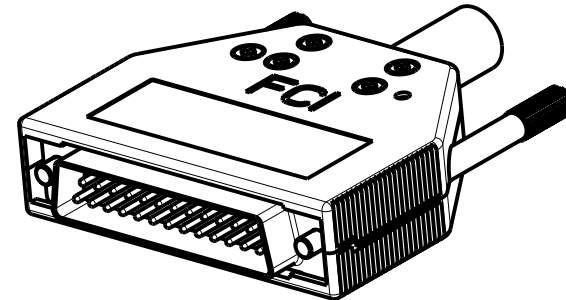

Copyright FCI.

www.fciconnect.com			surface - <input checked="" type="checkbox"/>	tolerance std	projection	mm
			ISO 1302	ISO 406 ISO 1101		
			TOLERANCES UNLESS OTHERWISE SPECIFIED			
Dr	M PESSON	2008/02/19	ANGULAR	0.X ±0.3	size A3	Scale 1:1
Eng	M PESSON	2008/02/19	LINEAR	0.XX ±0.1		
Chr	P LEGARE	2008/02/19	0° ±2°	0.XXX ±0.05	ECN LS08-0058	
Appr	P LEGARE	2008/02/19	Product family	- Spec ref		
			TITLE STRAIGHT METAL HOODS		dwg no	Rev.
			WITH 2 METAL CLAMPS		C-8655-1685	A
			catalog no	CUSTOMER	sheet 4 of 4	