



Product features

- Efficient LED technology with up to 100 lm/W and 40,000 hours of service life (L80/B50)
- Suitable for light management systems thanks to DALI
- Consistent design for LED: extremely flat with a height below 8 mm
- Perfectly matched system with OSRAM components
- Suitable for the illumination of VDU (visual display unit) workstations (UGR<19)
- Direct and indirect light distribution for a harmonious room atmosphere
- Available in two light colors (3000 K and 4000 K)

NEW:
Available
as DUO from
October
2014

Light is aesthetic ARKTIKA-P LED

The ultra-slim designer pendant luminaire for aesthetical office lighting – now with new canopy and as DUO version.

Light is OSRAM

siteco
AN OSRAM BUSINESS

OSRAM

Elegant eye-catcher for the office

With its purist design, the ARKTIKA-P LED fits perfectly into aesthetically sophisticated environments. In addition, its special reflector technology in a honey-comb design ensures that it fulfills all relevant standards for VDU workstations. The ARKTIKA-P with DALI allows the combination with external light management systems (presence and daylight control) and increases the potential for energy savings. Very efficient: ARKTIKA DUO – with its length of 2280 mm, it is suited for the illumination of three-person workspaces. It only requires two suspension points and is therefore particularly easy to install.

All versions of the ARKTIKA-P LED are pendant luminaires with a pendant kit and separate control gear in a canopy. Due to its doubled length, the ARKTIKA DUO opens up new solutions for large-area illumination.

Application areas

- Offices: desk lighting, VDU workstations, meeting rooms, open-plan offices
- Prestigious foyers and reception areas

DUO:
double
luminous
flux

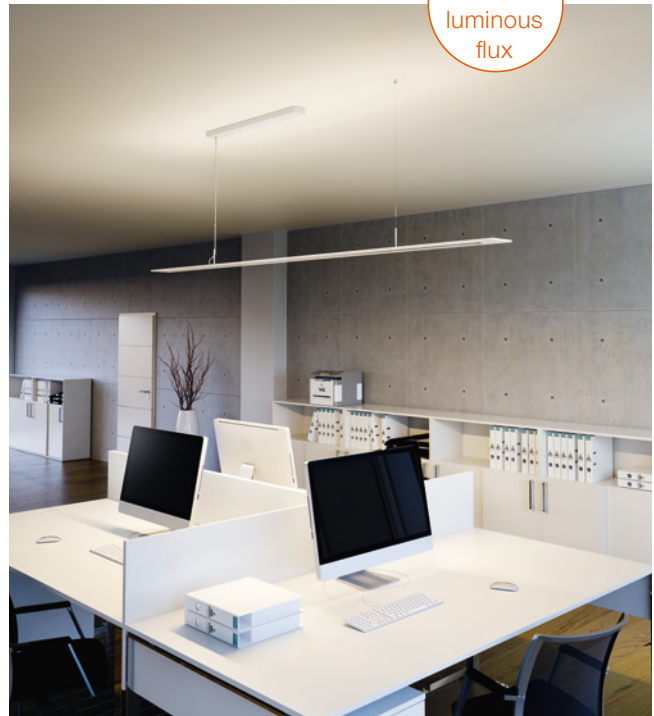

Special reflectors for high visual comfort

The sophisticated lighting technology of the ARKTIKA-P LED achieves uniform illumination without hard shadows. High-gloss, honey-comb-shaped darklight reflectors limit the glare of each individual LED and thus ensure highly efficient light distribution with minimized glare effects for comfortable viewing.

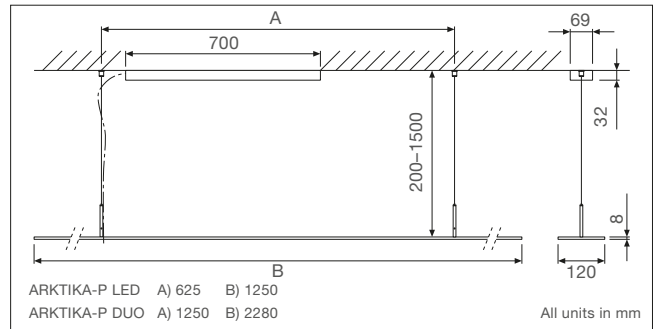
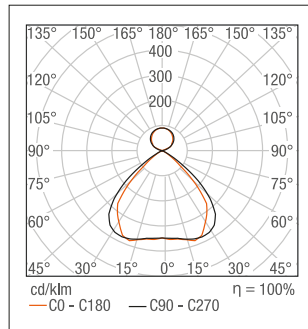

ARKTIKA-P LED

with new canopy | 220-240V, 1.8kg

Order number (EAN)	Order number (Siteco)	K	R _a	lm	W	EVG / VVG
4052899224711	0MB2512L40830	3000	> 85	3800 (75 %/25 %)	40	EVG
4052899224735	0MB251DL40830	3000	> 85	3800 (75 %/25 %)	40	EVG
4052899224728	0MB2512L40840	4000	> 85	4000 (75 %/25 %)	40	DALI
4052899224742	0MB251DL40840	4000	> 85	4000 (75 %/25 %)	40	DALI

— Energy efficiency classes of included LED modules: A++, A+, A. LED modules cannot be replaced.

ARKTIKA-P DUO DALI

220-240V, 3.2kg

Order number (EAN)	Order number (Siteco)	K	R _a	lm	W
4052899156968	0MB252DL80830	3000	> 85	7600 (75 %/25 %)	80
4052899157002	0MB252DL80840	4000	> 85	8000 (75 %/25 %)	80

— Energy efficiency classes of included LED modules: A++, A+, A. LED modules cannot be replaced.





OSRAM GmbH

Head office:

Marcel-Breuer-Strasse 6
80807 Munich | Germany
Phone +49 89 6213-0
Fax +49 89 6213-2020
www.osram.com

Siteco Beleuchtungstechnik GmbH

Head office:

Georg-Simon-Ohm-Strasse 50
83301 Traunreut | Germany
Phone +49 8669 33-0
Fax +49 8669 33-397
www.siteco.com

Member of

