

**Light Modules, Light/Sound Combination Modules, Piezo Single Tone Sound Module**  
**Éléments Lumineux, Éléments Lumineux et Sonore, Module à Signal Unique Piezo**  
**Leuchten-Module, Leuchten-Summer-Module, Piezo-Einzelton Module**  
**Moduli Luminosi, Moduli Luminosi/Acustici, Modulo a Tono Singolo Piezo**  
**Módulos Luminosos, Módulos Luminosos/Sonoros, Módulo Piezo de Tono Único**  
**Módulos de Luz, Módulos Combinados Luz/Sonido, Módulo Piezo de Tom Único**

FOR USE ON A FLAT SURFACE OF INDICATED TYPE ENCLOSURE

À UTILISER SUR UNE SURFACE PLANE DE L'ENCEINTE DU TYPE INDIQUÉ

ZUR VERWENDUNG AUF EINER FLACHEN OBERFLÄCHE DES ANGEgebenEN GEHÄUSETYP

DA UTILIZZARE SU UNA SUPERFICIE PIANA DEL TIPO DI CUSTODIA INDICATO

PARA USO SOBRE LA SUPERFICIE PLANA DE UN ENVOLVENTE DEL TIPO INDICADO

PARA USO EM SUPERFÍCIE PLANA NO TIPO DE PROTEÇÃO INDICADA



**ATTENTION:** Disconnect from power source to prevent electrical shock before installing or servicing. Check power supply voltage and frequency. Use only modules and lamps with the same voltage and frequency ratings.

**ATTENTION:** Déconnecter l'alimentation avant toute opération d'installation ou de maintenance, afin d'éviter les décharges électriques. Contrôler la tension et la fréquence d'alimentation. Utiliser seulement des éléments et des lampes de même tension et de même fréquence.

**ACHTUNG:** Strom abschalten um einen elektrischen Schock zu vermeiden während der Installation oder Wartungsarbeit. Prüfen Sie die Spannung und Frequenz. Benützen Sie ausschließlich Module und Glühlampen die die selbe Spannung und Frequenzen angeben.

**ATTENZIONE:** Scollegare dall'alimentazione prima dell'installazione e della messa in servizio. Controllare la tensione di alimentazione e la frequenza. Usare solo moduli e lampadas con la stessa tensione e frequenza.

**ATENÇÃO:** Desligar a alimentação antes de realizar qualquer intervenção. Verificar a tensão e frequência da alimentação. Só utilizar módulos e lâmpadas com as mesmas tensões e frequências.

**ATENCION:** Durante el proceso de instalación o mantenimiento desconectar la tensión de alimentación para evitar descargas eléctricas. Comprobar tensión y frecuencia de alimentación. Utilizar módulos y lámparas con la misma tensión y frecuencia.



**ATTENTION:** Do not use strobe lights around anyone suffering from cerebral disorders (epilepsy). Strobe lights may cause seizures to occur.

**ATTENTION:** Ne pas utiliser de stroboscopique à proximité de personnes souffrant de problèmes cérébraux (épilepsie), afin d'éviter tout risque de crise.

**ACHTUNG:** Verwenden Sie keine Blitzleuchten-Module im Nahbereich von Personen die an Epilepsie leiden.

**ATTENZIONE:** Non usare luci stroboscopiche nelle vicinanze di persone sofferenti di epilessia.

**ATENÇÃO:** Não usar luzes strobe perto de pessoas sofrendo de problemas cerebrais (epilepsia). Estas luzes podem provocar um ataque.

**ATENCION:** No utilizar luz estroboscópica alrededor de personas con problemas cerebrales (epilepsia). La luz estroboscópica puede causar ataques epilépticos.

**Base Mounting Procedure**  
**Montage du Socle de Fixation**  
**Basis-Modul Montage**  
**Montaggio della Base**  
**Procedimentos de Montagem da Base**  
**Montaje de la Base de Fijación**

Operating temperature: -25°C to +70°C  
 Température de fonctionnement: -25°C à +70°C  
 Betriebstemperatur: -25°C bis +70°C  
 Temperatura operativa: -25°C e +70°C  
 Temperatura operaciones: -25°C a +70°C  
 Temperatura para operacao: -25°C a +70°C

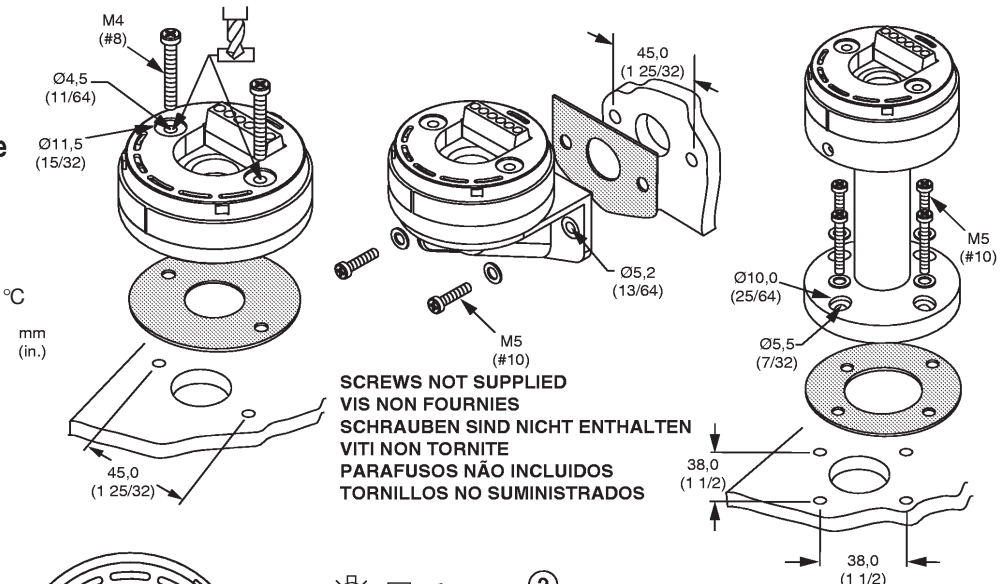

**Electrical Connection**  
**Raccordement Electrique**  
**Elektrischer Anschluß**  
**Collegamento Elettrico**  
**Ligações Elétricas**  
**Conexiones Eléctricas**

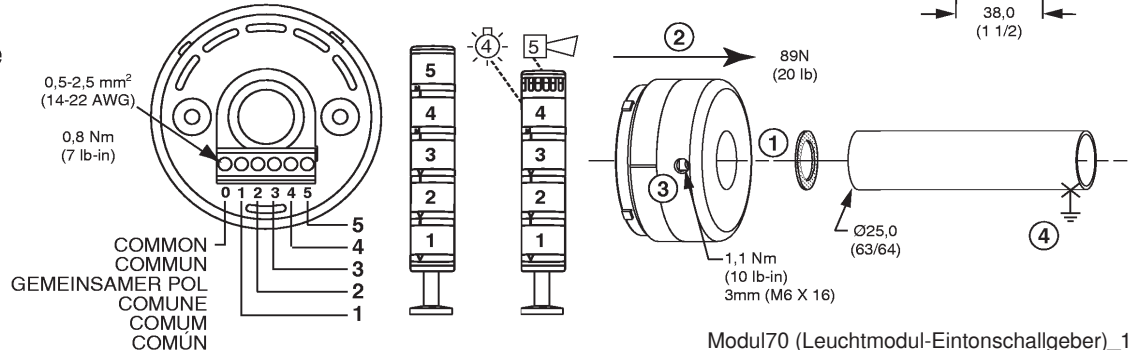

**Module and Cap Mounting Procedure**  
**Montage de L'élément et du Couvercle**  
**Modul und Kappe Montage**  
**Procedura di Montaggio del Modulo e del Calotta**  
**Procedimento de Montagem do Módulo e da Cobertura**  
**Procedimiento de Montaje de Módulo y Cubierta**

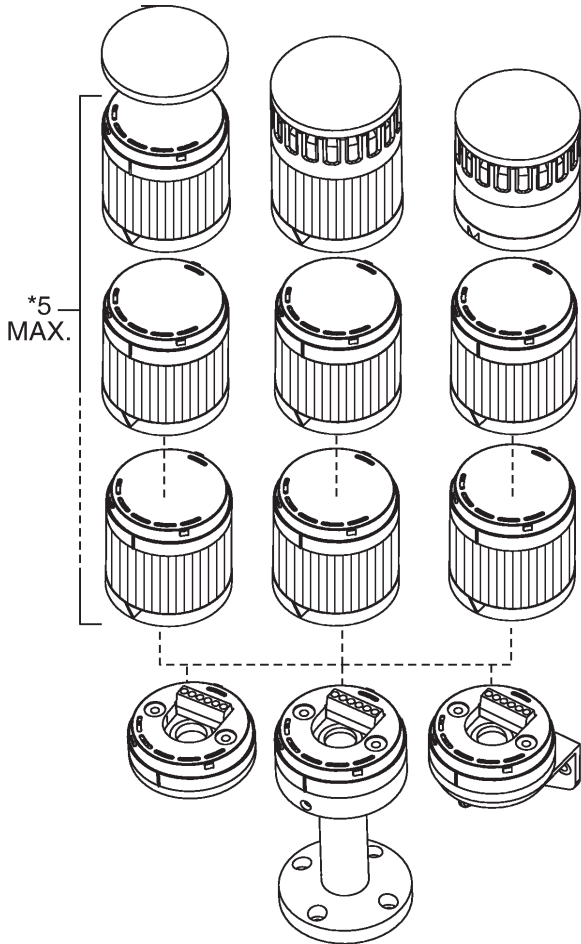

**Light/Sound Combination Modules, Piezo Single Tone Module**  
**Éléments Lumineux et Sonore, Module à Signal Unique Piezo**  
**Leuchten-Summer-Module, Piezo-Einzelton Module**  
**Moduli Luminosi/Acustici, Modulo a Tono Singolo Piezo**  
**Módulos Luminosos/Sonoros, Módulo Piezo de Tono Único**  
**Módulos Combinados Luz/Sonido, Módulo Piezo de Tom Único**

CONTINUOUS TONE  
 SIGNAL CONTINU  
 DAUERTON  
 CONTINUA  
 SOM CONTÍNUO  
 TONO CONTÍNUO

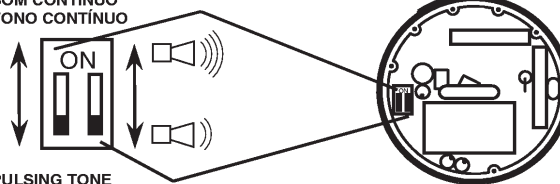

STROBE  
 STROBOSCOPIQUE  
 BLITZ  
 STROBOSCOPICA  
 ESTROBOSCÓPICO  
 ESTROBE

PULSING TONE  
 SIGNAL A IMPULSIONS  
 PULSIERENTER TON  
 PULSANTE  
 SOM PULSANTE  
 TONO PULSANTE

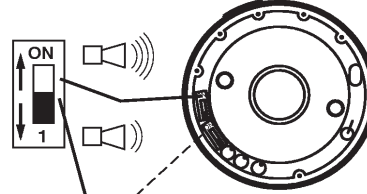

INCANDESCENT/SOCKET  
 MOUNT LED  
 LAMPE A INCANDESCENCE/  
 SUPPORT LED DE PLOT  
 GLÜHBIRNE/EINFÜHRUNG  
 MONTIERUNG LED  
 INCANDESCENZA/SUPPORTO LED  
 DELLA ZOCCOLO  
 INCANDESCENTE/MONTAJE LED  
 DEL SOCKET  
 INCANDESCENTE/LED DA  
 MONTAGEM DO SOQUETE

CONTINUOUS TONE  
 SIGNAL CONTINU  
 DAUERTON  
 CONTINUA  
 SOM CONTÍNUO  
 TONO CONTÍNUO



PULSING TONE  
 SIGNAL A IMPULSIONS  
 PULSIERENTER TON  
 PULSANTE  
 SOM PULSANTE  
 TONO PULSANTE

PIEZO  
 PIEZO  
 PIEZO  
 PIEZO  
 PIEZO  
 PIEZO

**Lamp Installation**  
**Installation de la Lampe**  
**Glühlampen-Montage**  
**Installazione della Lampada**  
**Montagem da Lâmpada**  
**Instalación de la Lámpara**

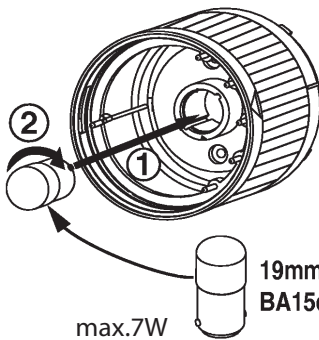

**Metal Foot Grounding**  
**Connecteur de Masse de l'embase en Métal**  
**Metallfußerdung**  
**Fondazione Metallica**  
**Suporte con pie Metálico**  
**Fundação do pé de Metal**

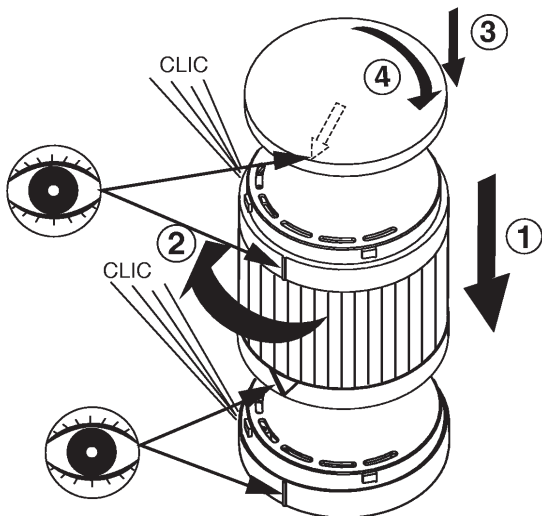
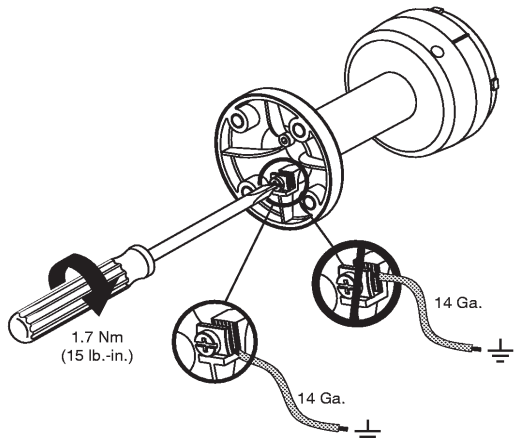

**Sound Modules**  
**Éléments Sonore**  
**Schallgeber-Modul**  
**Moduli Acustici**  
**Módulos Sonoros**  
**Módulos de Sonido**

**Single Tone Sound Module**  
**Tone Table**

**Élément Sonore Un Ton**  
**Table de Tonalités**

**Schallgeber-Modul (Einton)**  
**Tonartentabelle**

**Modulo Monotonale**

**Tabella dei Toni**

**Módulo de Um Som**

**Tabela de Sons**





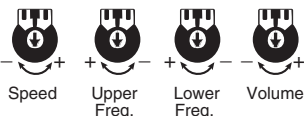
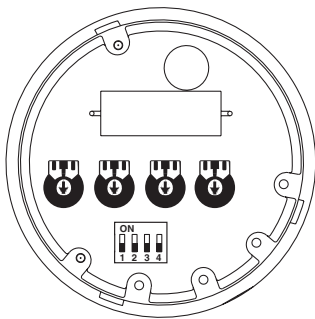



















**Módulo de Sonido de Un**

**Solo Tono Tabla de Tonos**



**Adjustable Sound Settings**  
**Réglages du Son**  
**Tonauswahl**  
**Regolarione dei Suoni**  
**Configuração dos Sons**  
**Ajustes de Sonido**

-25°C to +70°C  
 (-13°F to +158°F)

	Tone Signal Tonart Tono Som Tono	Speed Vitesse Taktfrequenz Velocità Velocidade Velocidad	Upper Frequency Fréquence Haute Obere Tonfrequenz Frequenza Superiore Frequência Superior Frecuencia Superior	Lower Frequency Fréquence Basse Untere Tonfrequenz Frequenza Inferiore Frequência Inferior Frecuencia Inferior	Volume Volume Lautstärke Volume Volume Volumen	
	Triangle Tone Triangulaire Dreieckton Triangolo Som Triangular Tono Triangulo		7-22 Hz	1500 Hz	500 Hz	80-100 dB(A)
	Continuous Tone Continu Dauerton Continuo Som Continuo Tono Continuo		—	①	500-1500 Hz	83-103 dB(A)
	Interrupted Tone Intermittent Unterbrochener Ton Intermittenza Som Intermitente Tono Interrumpido		0.5-1.5 Hz	①	500-1500 Hz	83-103 dB(A)
	Changing Tone Clignotant Wechselton Instabile Som Onda Quadrada Tono Cambiante		0.5-1.5 Hz	500-1500 Hz	500-1500 Hz	83-103 dB(A)
	Saw Tooth Tone Ascending Dents de Scie Ascendant Sägezahnnton Ansteigend Dente di Segna Ascendente Som Dente de Serra Ascendente Tono de Diente de Sierra Ascendente		0.5-1.5 Hz	500-1500 Hz	500-1500 Hz	83-103 dB(A)
	Saw Tooth Tone Descending Dents de Scie Descendant Sägezahnnton Abfallend Dente di Segna Discendente Som Dente de Serra Descendente Tono de Diente de Sierra Descendente		0.5-1.5 Hz	500-1500 Hz	500-1500 Hz	83-103 dB(A)
	Sine Wave Tone Sinusoïdale Sinuston Onda Sinusoidale Som Sinusoidal Tono de Onda Senoidal		0.5-1.5 Hz	500-1500 Hz	500-1500 Hz	82-102 dB(A)
	DIN Emergency Signal Signal D'Urgence-DIN DIN-Notsignal Segnale D'Emergenza DIN Sinal de Emergência DIN Tono de Emergencia DIN	DIN 33404	1 Hz	1200 Hz	500 Hz	82-102 dB(A)
	Siren (Non-repeating) Sirène (Non répétitif) Sirene (Nicht wiederkehrend) Sirena (Non ripetitivo) Sirena (Não repetitivo) Sirena (No repetitiva)		2-4 s	1500 Hz	500 Hz	83-103 dB(A)
	Signal Horn (Continuous Tone) Corne (Signal Continu) Hupe (Dauerton) Dorno (Tono Continuo) Corneta (Som Continuo) Señal de Bocina (Tono Continuo)		—	①	100-350 Hz	64-80 dB(A)
	Three Tone Gong Gong Trois Tons Dreiklanggong Gong a 3 Toni Gongo Três Tons Tres Tonos Gong		2-4 s	660 Hz 550 Hz 440 Hz		76-95 dB(A)
	Two Tone Gong Gong Deux Tons Zweiklanggong Gong a 2 Toni Gongo Dois Tons Dos Tonos Gong		2-3 s	550 Hz 440 Hz		75-93 dB(A)
	Gong Gong Gong Gongo Gongo Gong		1-3 s	①	500-1500 Hz	75-93 dB(A)

- ① Set to maximum (+).  
 Régler sur le maximum (+).  
 Auf Maximum (+) einstellen.  
 Impostare al massimo (+).  
 Ajuste máximo (+).  
 Establecer a máximo (+).

**Dual Tone Sound Module  
Tone Table**

**Élément Sonore Deux Tons  
Table de Tonalités**

**Schallgeber-Modul (Zweitön)  
Tonartentabelle**

**Modulo Bitonale  
Tabella dei Toni**

**Módulo Sonoro Duplo Som  
Tabela de Sons**

**Módulo de Sonido de Doble Tono  
Tabla de Tonos**

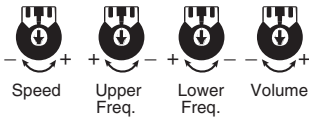
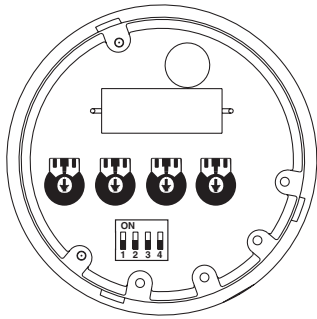

**Adjustable Sound Settings  
Réglages du Son  
Tonauswahl  
Regolarione dei Suoni  
Configuração dos Sons  
Ajustes de Sonido**

-25°C to +70°C  
(-13°F to +158°F)

	<b>Tone A Signal A Ton A Tono A Som A Tono A</b>	<b>Tone B Signal B Ton B Tono B Som B Tono B</b>	
	Triangle Tone Triangulaire Dreieckton Triangolo Som Triangular Tono Triangulo		Continuous Tone Continu Dauerton Continuo Som Continuo Tono Continuo
	Continuous Tone Continu Dauerton Continuo Som Continuo Tono Continuo		Changing Tone Clignotant Wechselton Instabile Som Onda Quadrada Tono Cambiante
	Continuous Tone Continu Dauerton Continuo Som Continuo Tono Continuo		Interrupted Tone Intermittent Unterbrochener Ton Intermittenza Som Intermittente Tono Interrumpido
	Interrupted Tone Intermittent Unterbrochener Ton Intermittenza Som Intermittente Tono Interrumpido		Three Tone Gong Gong Trois Tons Dreiklanggong Gong a 3 Toni Gongo Três Tons Tres Tonos Gong
	Interrupted Tone Intermittent Unterbrochener Ton Intermittenza Som Intermittente Tono Interrumpido		Siren (Non-repeating) Sirène (Non répétitif) Sirene (Nicht wiederkehrend) Sirena (Non ripetitivo) Sirena (Não repetitivo) Sirena (No repetitiva)
	Changing Tone Clignotant Wechselton Instabile Som Onda Quadrada Tono Cambiante		DIN Emergency Signal Signal D'Urgence-DIN DIN-Notsignal Segnale D'Emergenza DIN Sinal de Emergência DIN Tono de Emergencia DIN
	Saw Tooth Tone Ascending Dents de Scie Ascendant Sägezahn Ton Ansteigend Dente di Segna Ascendente Som Dente de Serra Ascendente Tono de Diente de Sierra Ascendente		Continuous Tone Continu Dauerton Continuo Som Continuo Tono Continuo
	Saw Tooth Tone Descending Dents de Scie Descendant Sägezahn Ton Abfallend Dente di Segna Discendente Som Dente de Serra Descendente Tono de Diente de Sierra Descendente		Interrupted Tone Intermittent Unterbrochener Ton Intermittenza Som Intermittente Tono Interrumpido
	Sine Wave Tone Sinusoïdale Sinuston Onda Sinusoidale Som Sinusoidal Tono de Onda Senoidal		DIN Emergency Signal Signal D'Urgence-DIN DIN-Notsignal Segnale D'Emergenza DIN Sinal de Emergência DIN Tono de Emergencia DIN
	DIN Emergency Signal Signal D'Urgence-DIN DIN-Notsignal Segnale D'Emergenza DIN Sinal de Emergência DIN Tono de Emergencia DIN	DIN 33404	Three Tone Gong (Non-repeating) Gong Trois Tons (Non répétitif) Dreiklanggong (Nicht wiederkehrend) Gong a 3 Toni (Non ripetitivo) Gongo Três Tons (Não repetitivo) Tres Tonos Gong (No repetitiva)
	Siren (Non-repeating) Sirène (Non répétitif) Sirene (Nicht wiederkehrend) Sirena (Non ripetitivo) Sirena (Não repetitivo) Sirena (No repetitiva)		Triangle Tone Triangulaire Dreieckton Triangolo Som Triangular Tono Triangulo
	Signal Horn (Continuous Tone) Corne (Signal Continu) Hupe (Dauerton) Dorno (Tono Continuo) Corneta (Som Continuo) Señal de Bocina (Tono Continuo)		Continuous Tone Continu Dauerton Continuo Som Continuo Tono Continuo
	Three Tone Gong Gong Trois Tons Dreiklanggong Gong a 3 Toni Gongo Três Tons Tres Tonos Gong		Sine Wave Tone Sinusoïdale Sinuston Onda Sinusoidale Som Sinusoidal Tono de Onda Senoidal
	Two Tone Gong Gong Deux Tons Zweiklanggong Gong a 2 Toni Gongo Dois Tons Dos Tonos Gong		Two Tone Gong (Non-repeating) Gong Deux Tons (Non répétitif) Zweiklanggong (Nicht wiederkehrend) Gong a 2 Toni (Non ripetitivo) Gongo Dois Tons (Não repetitivo) Dos Tonos Gong (No repetitiva)
	Gong Gong Gong Gongo Gongo Gong		Continuous Tone Continu Dauerton Continuo Som Continuo Tono Continuo

**Dual Tone Sound Module**  
**Élément Sonore Deux Tons**  
**Schallgeber-Modul (Zweitono)**  
**Modulo Bitonale**  
**Módulo Sonoro Duplo Som**  
**Módulo de Sonido de Doble Tono**



FOR USE ON A FLAT SURFACE OF INDICATED TYPE ENCLOSURE  
 À UTILISER SUR UNE SURFACE PLANE DE L'ENCEINTE DU TYPE INDIQUÉ  
 ZUR VERWENDUNG AUF EINER FLACHEN OBERFLÄCHE DES ANGEGBENEN GEHÄUSETYP  
 DA UTILIZZARE SU UNA SUPERFICIE PIANA DEL TIPO DI CUSTODIA INDICATO  
 PARA USO SOBRE LA SUPERFICIE PLANA DE UN ENVOLVENTE DEL TIPO INDICADO  
 PARA USO EM SUPERFÍCIE PLANA NO TIPO DE PROTEÇÃO INDICADA

**WARNING**

**AVERTISSEMENT**

**WARNUNG**

**AVVERTENZA**

**ATENÇÃO**

**ADVERTENCIA**

Check power supply voltage and frequency. Use only modules and lamps with the same voltage and frequency ratings. Disconnect from power source to prevent electrical shock before installing or servicing.

Controler la tension et la fréquence d'alimentation. Utiliser seulement des éléments et des lampes de meme tension et de meme fréquence. Déconnecter l'alimentation avant toute opération d'installation ou de maintenance, afin d'éviter les décharges électriques.

Prüfen Sie die Spannung und Frequenz. Benützen Sie ausschließlich Module und Glühlampen die die selbe Spannung und Frequenzen angeben. Strom abschalten um einen elektrischen Schock zu vermeiden während der Installation oder Wartungsarbeit.

Controllare la tensione di alimentazione e la frequenza. Usare solo moduli e lampadas con la stessa tensione e frequenza. Scollegare dall'alimentazione prima dell'installazione e della messa in servizio.

Verificar a tensão e frequência da alimentação. Só utilizar módulos e lâmpadas com as mesmas tensões e frequências. Desligar a alimentação antes de realizar qualquer intervenção.

Comprobar tensión y frecuencia de alimentación. Utilizar módulos y lámparas con la misma tensión y frecuencia. Durante el proceso de instalación o mantenimiento desconectar la tensión de alimentación para evitar descargas eléctricas.

**Base Mounting Procedure**  
**Montage du Socle de Fixation**  
**Basis-Modul Montage**  
**Montaggio della Base**  
**Procedimentos de Montagem da Base**  
**Montaje de la Base de Fijación**

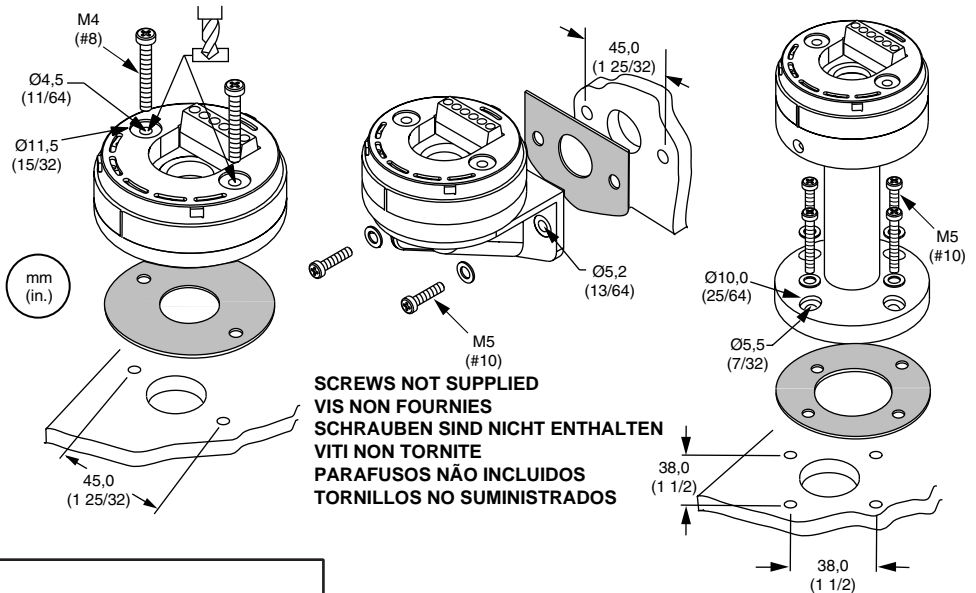

Operating temperature: -25°C to +70°C  
 Température de fonctionnement: -25°C à +70°C  
 Betriebstemperatur: -25°C bis +70°C  
 Temperatura operativa: -25°C e +70°C  
 Temperatura operacionais: -25°C a +70°C  
 Temperatura para operacao: -25°C a +70°C

**SCREWS NOT SUPPLIED**  
**VIS NON FOURNIES**  
**SCHRAUBEN SIND NICHT ENTHALTEN**  
**VITI NON TORNITE**  
**PARAFUSOS NÃO INCLUIDOS**  
**TORNILLOS NO SUMINISTRADOS**

**Metal Foot Grounding**  
**Connecteur de Masse de l'embase en Métal**  
**Metallfußberdung**  
**Fondazione Metallica**  
**Suporte con pie Metálico**  
**Fundação do pé de Metal**

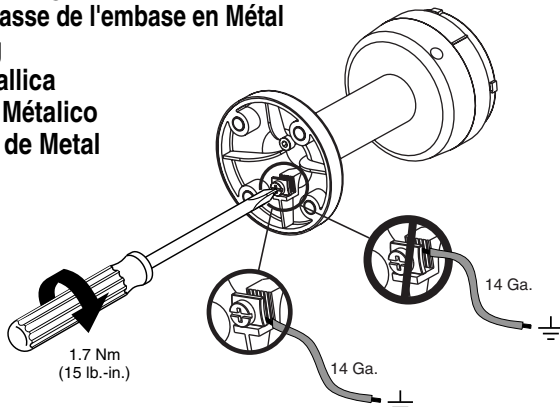

- Important:** Do not adjust setscrew on pole base. Ingress rating will be lost.
- Important:** Ne pas modifier le réglage de la vis. Le système ne serait plus étanche.
- Wichtig:** Die Fixierschraube des Rohrständer-Basis-Modules darf nicht verändert werden, da dies zur Beeinträchtigung der Schutzart-Klassifikation führt.
- Importante:** Non regolare la vite di fissaggio della base a tubo. Le caratteristiche d'ingresso verrebbero perse.
- Importante:** Não ajustar os parafusos na base do pólo. Pode perder a capacidade de encaixe.
- Importante:** No aflojar los tornillos de la base. El valor de entrada se perderá.

**Electrical Connection**  
**Raccordement Electrique**  
**Elektrischer Anschluß**  
**Collegamento Elettrico**  
**Ligações Eléctricas**  
**Conexiones Eléctricas**

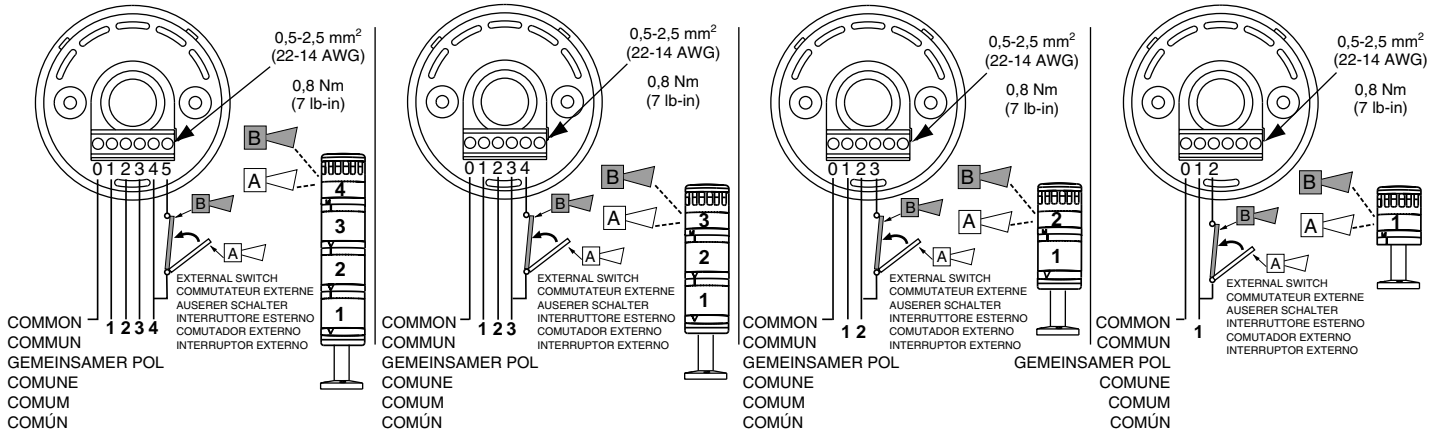

**Module Mounting Procedure**  
**Montage des Eléments**  
**Modul-Montage**  
**Montaggio dei Moduli**  
**Procedimento de Montagem do Módulo**  
**Montaje del Módulo de Fijación**

