

Lieferzustand:
delivery condition:

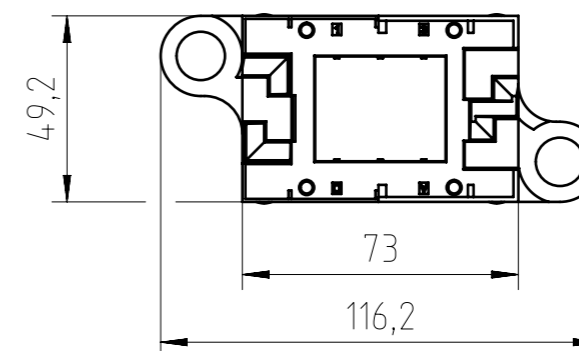

Schrauben lose beigelegt
screws attached loose

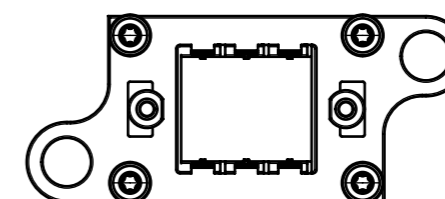
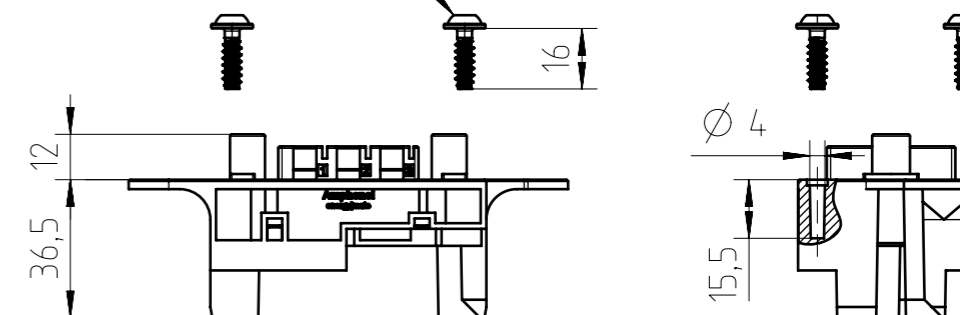

Hinweise zum Einbau siehe Seite 2
information for assembly see page 2

General Characteristics	Standard	Value
size		3 modules
tolerance compensation		both connectors floating: ±5mm one con. fix, other con. floating: ±2,5mm both connectors fixed: ±0mm
guiding range (suitable design of customers' devices to allow movement required)		one con. fix, other con. floating: up to ±7,5mm both connectors fixed: up to ±10mm
panel cut out		see page 2
protection class	IEC 60529	IP20
Climatical Characteristics	Standard	Value
climatic category	IEC 60068-1	40 / 125 / 21
upper temperature	IEC 60512-11-9	+125°C
lower temperature	IEC 60512-11-10	-40°C
Mechanical Characteristics	Standard	Value
mechanical operation	IEC 60512-9-1	≥500 mating cycles
Materials	Standard	Value
module frame		PA-GF
flammability	UL 94	V-0
screws		steel Zn-plated

Alle technischen Daten wurden unter Laborbedingungen ermittelt und können im Praxisbetrieb abweichen. Es handelt sich bei den Angaben weder um Beschaffenheits- noch um Haltbarkeitsgarantien. Beim Gebrauch von Fremdkontakten wird für abweichende Eigenschaften keine Haftung übernommen. All technical data have been measured in a laboratory environment and can be different during practical usage of the product. Any product information is for descriptive usage only and not legally binding, particularly the information does not constitute or provide any legal guarantees ("Beschaffenheitsgarantie" or "Haltbarkeitsgarantie").
By using contacts from other manufacturers the liability of the part is not assumed

Gewicht (errechnet) / Calc WT: 61,8 kg		Zul. Abw./Tolerances:		Maßstab / Scale: 1:2		A3	
Prüfmaß / Testdimension		ISO 2768-mH		DIN / ISO 13715		CUSTOMER DRAWING	
Teileindex / Partindexnumber:		Gez. 10.12.2020		Drawn PWOELFFLE		energymate 3 Module	
Bagatelle change:		Status Released		Gepr. 16.12.2020		energymate 3 modules	
		Checked MBERTSCH		Amphenol Tuchel Industrial GmbH		Blatt / Sheet 1	
01 202000172		15.12.2020		PWOLF		M C146 N03 004 G8	
Index Änderung / Description		Datum / Date		Name		Ers. f. / Replacement for:	

Copying of this document and giving it to others and the use or communication of the contents thereof, are forbidden without express authority. Offenders are liable to the payment of damages. All rights are reserved in the event of the grant of a patent or the registration of the utility model or design.
 Weitergabe sowie Vervielfältigung dieser Unterlage, Verwertung und Mitteilung ihres Inhalts nicht gestattet, soweit nicht ausdrücklich zugestanden. Zuwiderhandlungen verpflichten zu Schadenersatz. Alle Rechte für den Fall der Patenterteilung oder Gebrauchsmuster-Eintragung vorbehalten.

FAI2020-004486
NXM-V01

Montageausschnitt feste Lagerung /
panel cut-out fixed assembly :

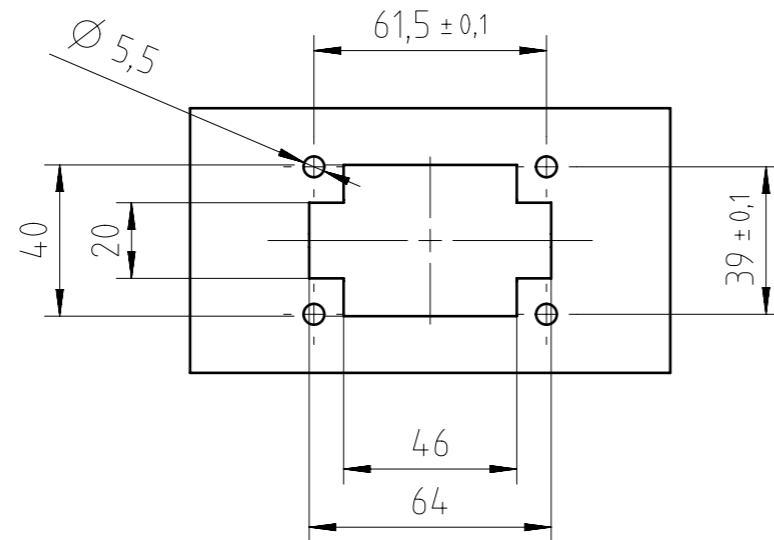

Gesteckter Zustand /
mated condition :

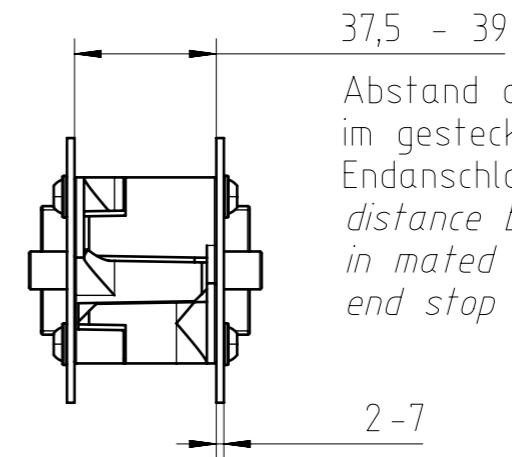

Abstand der Steckpartner
im gesteckten Zustand;
Endanschlag bei 37,5mm
distance between the sheets
in mated condition;
end stop at 37,5mm

Blechstärke;
auf Anfrage: dickere Bleche mit
längeren Schrauben möglich
sheet metal thickness;
on demand: thicker sheet metals
possible by using longer screws

Anziehdrehmoment / tightening torque :

sheet metal thickness	tightening torque
2mm	5,3Nm
3mm	4,9Nm
4mm	4,5Nm
5mm	4,1Nm
6mm	3,7Nm
7mm	3,2Nm

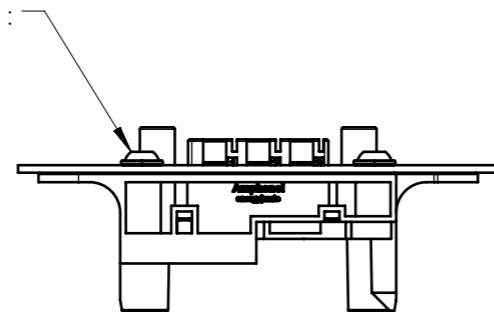

- Zugentlastung erforderlich um Kräfte durch die Verkabelung auf den Steckverbinder zu verhindern
- zulässige Materialien für Montageblech:
 - Stahl
 - Al-Legierungen ausgehärtet
- Montageblech Ebenheit: 0,1
- strain-relief necessary to avoid cable forces to the connector
- approved materials for sheet metal:
 - steel
 - aluminium-alloys hardened
- sheet metal flatness: 0,1

Gewicht (errechnet) / Calc WT : 61,8 kg		Zul. Abw./Tolerances :		Maßstab / Scale : 1:2	A3	
Prüfmaß / Testdimension		ISO 2768-mH		CUSTOMER DRAWING		
Teileindex / Partindexnumber:		DIN / ISO 13715		energylmate 3 Module		
Bagatelle change:		Gez. Drawn 10.12.2020 PWOELFFLE		energylmate 3 modules		
		Status Released				
		Gepr. Checked 16.12.2020 MBERTSCH				
		Amphenol Tuchel Industrial GmbH		M C146 N03 004 G8		Blatt / Sheet 2
01	202000172	15.12.2020	PWOLF	Ers. f. / Replacement for :		2 Bl.
Index	Änderung / Description	Datum / Date	Name			

Coping of this document and giving it to others and the use or communication of the contents thereof, are forbidden without express authority. Offenders are liable to the payment of damages. All rights are reserved in the event of the grant of a patent or the registration of the utility model or design.

Weitergabe sowie Vervielfältigung dieser Unterlage, Verwertung und Mitteilung ihres Inhalts nicht gestattet, soweit nicht ausdrücklich zugestanden. Zuwiderhandlungen verpflichten zu Schadensersatz. Alle Rechte für den Fall der Patenterteilung oder Gebrauchsmuster-Eintragung vorbehalten.

FAI2020-004486
 NXM-V01