

PRODUCT DATA SHEET

PL22SL Series (Single/Bi-colour 2 wire)

Ø22mm stainless steel panel lights

Product Configuration

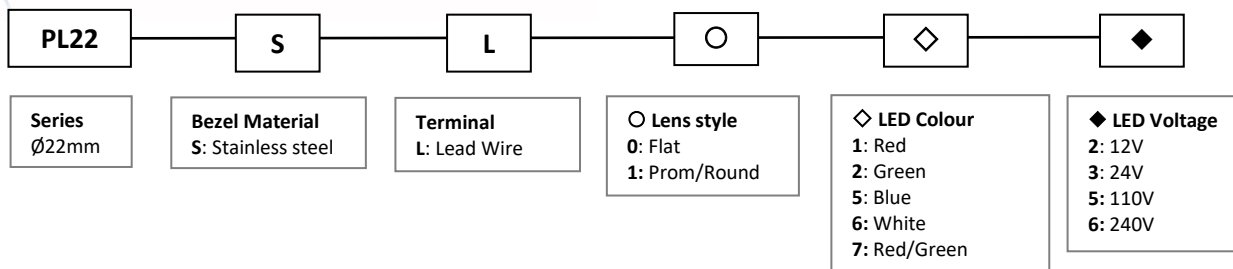

Example Part Number

PL22SL023 Panel indicator 22mm diameter, stainless steel bezel, lead wire terminated, flat lens, Green, 24V.

Outline Dimensions (mm) - Not to scale

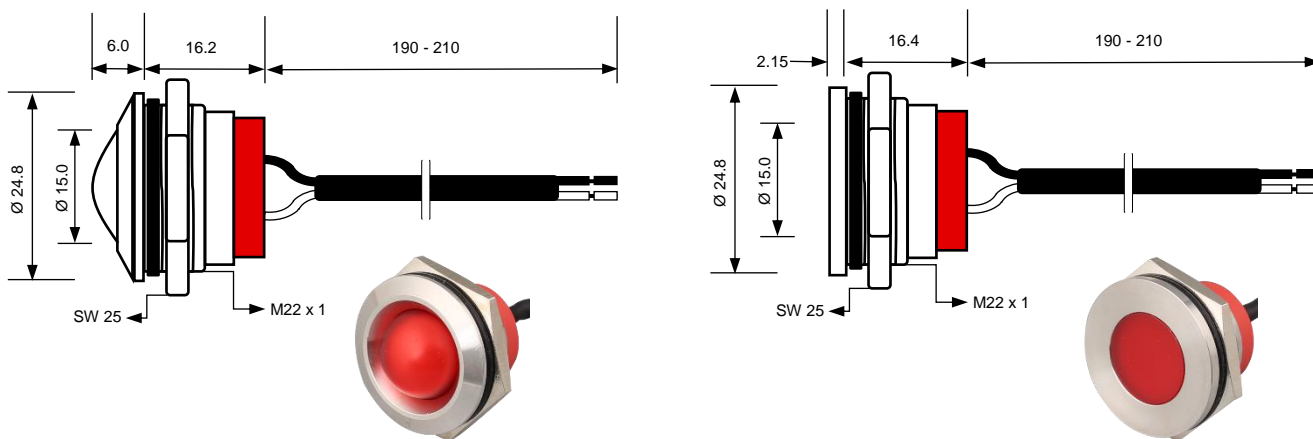

Colour	Typ. Wave length (Nm)	Typ. Colour Temp (K)	Viewing Angle (°)		Typ. Luminous Intensity (mcd)	
			Rnd	Flat	Rnd	Flat
Red	625	N/A	110	110	970	860
Green	520	N/A	110	110	1800	1500
Blue	470	N/A	110	110	500	400
White	N/A	6000	110	110	2400	2000

Notes:

- | | | |
|----|----------------------------|--|
| 1 | Optical Data | Applies to component LED @ 25°C, 20mA |
| 2 | Red/Green variant | Illuminates Red or Green dependant on Black wire ± polarity. |
| 3 | Body Material | Bezel - Stainless Steel 304, Housing – PA6 |
| 4 | Wire Gauge | 24 AWG |
| 5 | LED Life (Average) | 50000 Hrs |
| 6 | Operating Current | AC/DC |
| 7 | Current Rating | ≤ 20mA |
| 8 | Protection | IP67 |
| 9 | Environmental | RoHS & REACH SVHC compliant |
| 10 | Marking | Voltage, colour, CE/UKCA (110V, 240V only) |
| 11 | Operating Temp | -25°C~+65°C |
| 12 | Max Panel Thickness | Advised 5mm, Absolute 6mm. |