

# E4980A Precision LCR Meter

20 Hz to 2 MHz

# E4980AL Precision LCR Meter

20 Hz to 300 kHz/500 kHz/1 MHz



Fully compliant to  
LXI Class C specification

## Table of Contents

Definitions .....	3
How to Use Tables .....	3
E4980A/E4980AL .....	3
Basic Specifications .....	4
Measurement functions .....	4
Test signal .....	5
Measurement display ranges .....	7
Absolute measurement accuracy .....	8
Relative accuracy .....	10
Basic accuracy .....	13
Short offset $Z_s$ .....	15
Open offset $Y_o$ .....	16
Calibration accuracy $A_{cal}$ .....	17
Measurement accuracy .....	19
Compensation function .....	20
DC bias signal .....	21
Measurement assistance functions .....	21
Options .....	22
Frequency options .....	22
Interface options .....	23
Other options .....	23
Power and DC bias enhancement specification .....	23
Test signal .....	24
DCR measurement specification .....	28
General Specifications .....	30
Supplemental Information .....	35
Settling time .....	35
Measurement circuit protection .....	36
Measurement time .....	36
Display time .....	40
Measurement data transfer time .....	41
Maximum DC bias current .....	42
Relative measurement accuracy with bias current isolation .....	43
DC bias settling time .....	44
Web Resources .....	45

## Definitions

All specifications apply to the conditions of a 0 to 55°C temperature range, unless otherwise stated, and 30 minutes after the instrument has been turned on.

**Specifications (spec.):** Warranted performance. Specifications include guardbands to account for the expected statistical performance distribution, measurement uncertainties, and changes in performance due to environmental conditions.

Supplemental information is provided as information that is useful in operating the instrument, but is not covered by the product warranty. This information is classified as either typical or nominal.

**Typical (typ.):** Expected performance of an average unit without taking guardbands into account.

**Nominal (nom.):** A general descriptive term that does not imply a level of performance.

## How to Use Tables

When measurement conditions fall under multiple categories in a table, apply the best value.

For example, basic accuracy  $A_b$  is 0.10% under the following conditions;

Measurement time mode	SHORT
Test frequency	125 Hz
Test signal voltage	0.3 Vrms

## E4980A/E4980AL

The E4980A is the model number of the 20 Hz to 2 MHz frequency range LCR meter. The E4980AL is the model number of the 20 Hz to 300 kHz, 500 kHz or 1 MHz frequency range LCR meter. See the E4980A/E4980AL Configuration Guide (5989-8321EN) for more details.

Frequency range	Model number and option
20 Hz to 2 MHz	E4980A
20 Hz to 1 MHz	E4980AL-102
20 Hz to 500 kHz	E4980AL-052
20 Hz to 300 kHz	E4980AL-032

## Basic Specifications

### Measurement functions

#### Measurement parameters

- Cp-D, Cp-Q, Cp-G, Cp-Rp
- Cs-D, Cs-Q, Cs-Rs
- Lp-D, Lp-Q, Lp-G, Lp-Rp, Lp-Rdc
- Ls-D, Ls-Q, Ls-Rs, Ls-Rdc
- R-X
- Z- $\theta$ d, Z- $\theta$ r
- G-B
- Y-  $\theta$ d, Y- $\theta$ r
- Vdc-Idc<sup>1</sup>

#### Definitions

<b>Cp</b>	Capacitance value measured with parallel-equivalent circuit model
<b>Cs</b>	Capacitance value measured with series-equivalent circuit model
<b>Lp</b>	Inductance value measured with parallel-equivalent circuit model
<b>Ls</b>	Inductance value measured with series-equivalent circuit model
<b>D</b>	Dissipation factor
<b>Q</b>	Quality factor (inverse of D)
<b>G</b>	Equivalent parallel conductance measured with parallel-equivalent circuit model
<b>Rp</b>	Equivalent parallel resistance measured with parallel-equivalent circuit model
<b>Rs</b>	Equivalent series resistance measured with series-equivalent circuit model
<b>Rdc</b>	Direct-current resistance
<b>R</b>	Resistance
<b>X</b>	Reactance
<b>Z</b>	Impedance
<b>Y</b>	Admittance
<b><math>\theta</math>d</b>	Phase angle of impedance/admittance (degree)
<b><math>\theta</math>r</b>	Phase angle of impedance/admittance (radian)
<b>B</b>	Susceptance
<b>Vdc</b>	Direct-current voltage
<b>Idc</b>	Direct-current electricity

**Deviation measurement function:** Deviation from reference value and percentage of deviation from reference value can be output as the result.

**Equivalent circuits for measurement:** Parallel, Series

1. E4980A-001 is required.

**Impedance range selection:** Auto (auto range mode), manual (hold range mode)

**Trigger mode:** Internal trigger (INT), manual trigger (MAN), external trigger (EXT), GPIB trigger (BUS)

Range	0 s - 999 s
Resolution	100 $\mu$ s (0 s $\leq$ - $\leq$ 100 s) 1 ms (100 s < - $\leq$ 999 s)

Table 1. Trigger delay time

Range	0 s - 999 s
Resolution	100 $\mu$ s (0 s $\leq$ - $\leq$ 100 s) 1 ms (100 s < - $\leq$ 999 s)

Table 2. Step delay time

**Measurement terminal:** Four-terminal pair

**Test cable length:** 0 m, 1 m, 2 m, 4 m

**Measurement time modes:** Short mode, medium mode, long mode.

Range	1 - 256 measurements
Resolution	1

Table 3. Averaging

## Test signal

Test frequencies	20 Hz - 2 MHz (E4980A) 20 Hz - 1 MHz (E4980AL-102) 20 Hz - 500 kHz (E4980AL-052) 20 Hz - 300 kHz (E4980AL-032)
Resolution	0.01 Hz (20 Hz - 99.99 Hz) 0.1 Hz (100 Hz - 999.9 Hz) 1 Hz (1 kHz - 9.999 kHz) 10 Hz (10 kHz - 99.99 kHz) 100 Hz (100 kHz - 999.9 kHz) 1 kHz (1 MHz - 2 MHz)
Measurement accuracy	$\pm$ 0.01%

Table 4. Test frequencies

Normal	Program selected voltage or current at the measurement terminals when they are opened or short-circuited, respectively.
Constant	Maintains selected voltage or current at the device under test (DUT) independently of changes in impedance of DUT.

Table 5. Test signal modes

### Signal level

Range	0 Vrms - 2.0 Vrms		
Resolution	100 $\mu$ Vrms (0 Vrms $\leq$ - $\leq$ 0.2 Vrms) 200 $\mu$ Vrms (0.2 Vrms < - $\leq$ 0.5 Vrms) 500 $\mu$ Vrms (0.5 Vrms < - $\leq$ 1 Vrms) 1 mVrms (1 Vrms < - $\leq$ 2 Vrms)		
Accuracy	Normal	$\pm(10\% + 1 \text{ mVrms})$	Test frequency $\leq$ 1 MHz: spec. Test frequency > 1 MHz: typ.
	Constant <sup>1</sup>	$\pm(6\% + 1 \text{ mVrms})$	Test frequency $\leq$ 1 MHz: spec. Test frequency > 1 MHz: typ.

Table 6. Test signal voltage

Range	0 Arms - 20 mArms		
Resolution	1 $\mu$ Arms (0 Arms $\leq$ - $\leq$ 2 mArms) 2 $\mu$ Arms (2 mArms < - $\leq$ 5 mArms) 5 $\mu$ Arms (5 mArms < - $\leq$ 10 mArms) 10 $\mu$ Arms (10 mArms < - $\leq$ 20 mArms)		
Accuracy	Normal	$\pm(10\% + 10 \mu\text{Arms})$	Test frequency $\leq$ 1 MHz: spec. Test frequency > 1 MHz: typ.
	Constant <sup>1</sup>	$\pm(6\% + 10 \mu\text{Arms})$	Test frequency $\leq$ 1 MHz: spec. Test frequency > 1 MHz: typ.

Table 7. Test signal current

**Output impedance:** 100  $\Omega$  (nominal)

Test signal level monitor function

- Test signal voltage and test signal current can be monitored.
- Level monitor accuracy:

1. When auto level control function is on.

Test signal voltage <sup>2</sup>	Test frequency	Specification
5 mVrms - 2 Vrms	≤ 1 MHz > 1 MHz	±(3% of reading value + 0.5 mVrms) ±6% of reading value + 1 mVrms)

Table 8. Test signal voltage monitor accuracy (Vac)

Test signal current <sup>2</sup>	Test frequency	Specification
50 μArms - 20 mArms	≤ 1 MHz > 1 MHz	±(3% of reading value + 5 μArms) ±(6% of reading value + 10 μArms)

Table 9. Test signal current monitor accuracy (Iac)

## Measurement display ranges

Table 10 shows the range of measured value that can be displayed on the screen. For the effective measurement ranges, refer to Figure 1 impedance measurement accuracy example.

Parameter	Measurement display range
Cs, Cp	± 1.000000 aF to 999.9999 EF
Ls, Lp	±1.000000 aH to 999.9999 EH
D	±0.000001 to 9.999999
Q	±0.01 to 99999.99
R, Rs, Rp, X, Z, Rdc	±1.000000 aΩ to 999.9999 EΩ
G, B, Y	±1.000000 aS to 999.9999 ES
Vdc	±1.000000 aV to 999.9999 EV
Idc	±1.000000 aA to 999.9999 EA
θr	±1.000000 arad to 3.141593 rad
θd	±0.0001 deg to 180.0000 deg
Δ%	±0.0001% to 999.9999%

Table 10. Allowable display ranges for measured values

a:  $1 \times 10^{-18}$ , E:  $1 \times 10^{18}$

1. When auto level control function is on.
2. This is not an output value but rather a displayed test signal level.

## Absolute measurement accuracy

The following equations are used to calculate absolute accuracy.

Absolute accuracy Aa of |Z|, |Y|, L, C, R, X, G, B (L, C, X, and B accuracies apply when  $D_x \leq 0.1$ , R and G accuracies apply when  $Q_x \leq 0.1$ )

When  $D_x \geq 0.1$ , multiply Acal by  $\sqrt{1+D_x^2}$  for L, C, X, and B accuracies

When  $Q_x \geq 0.1$ , multiply Acal by  $\sqrt{1+Q_x^2}$  for R and G accuracies

Under an AC magnetic field, the following equation is applied to the measurement accuracy.

$$A \times (1 + B \times (2 + 0.5 / V_s))$$

where A Absolute accuracy  
B Magnetic flux density [Gauss]  
Vs Test signal voltage level [Volts]

### Equation 1. $Aa = Ae + Acal$

Aa Absolute accuracy (% of reading value)  
Ae Relative accuracy (% of reading value)  
Acal Calibration accuracy (%)

where G accuracy is applied only to G-B measurements.

### D accuracy (when $D_x \leq 0.1$ )

#### Equation 2. $De + \theta_{cal}$

Dx Measured D value  
De Relative accuracy of D  
 $\theta_{cal}$  Calibration accuracy of  $\theta$  (radian)

when  $0.1 < D_x \leq 1$ , multiply  $\theta_{cal}$  by  $(1 + D_x)$

### Q accuracy (When $Q_x \times Da < 1$ )

$$\text{Equation 3. } \pm \frac{(Q_x^2 \times Da)}{(1 \pm Q_x \times Da)}$$

Qx Measured Q value  
Da Absolute accuracy of D



## **θ accuracy**

### **Equation 4.    θ<sub>e</sub> + θ<sub>cal</sub>**

θ<sub>e</sub>    Relative accuracy of θ (degree)  
θ<sub>cal</sub>    Calibration accuracy of θ (degree)

G accuracy (when Dx ≤ 0.1)

**Equation 5.    B<sub>x</sub> + Da (S)**  
**B<sub>x</sub> = 2πfCx =  $\frac{1}{2πfLx}$**

Dx    Measured D value  
B<sub>x</sub>    Measured B value (S)  
Da    Absolute accuracy of D  
f    Test frequency (Hz)  
C<sub>x</sub>    Measured C value (F)  
L<sub>x</sub>    Measured L value (H)

where the accuracy of G is applied to Cp-G measurements.

Absolute accuracy of Rp (when Dx ≤ 0.1)

**Equation 6.    ±  $\frac{R_{px} \times Da}{Dx \mp Da}$  (Ω)**

R<sub>px</sub>    Measured Rp value (Ω)  
Dx    Measured D value  
Da    Absolute accuracy of D

Absolute accuracy of Rs (when Dx ≤ 0.1)

**Equation 7.    X<sub>x</sub> × Da                    (Ω)**  
**X<sub>x</sub> =  $\frac{1}{2πfCx}$  = 2πfL<sub>x</sub>**

Dx    Measured D value  
X<sub>x</sub>    Measured X value (Ω)  
Da    Absolute accuracy of D  
f    Test frequency (Hz)  
C<sub>x</sub>    Measured C value (F)  
L<sub>x</sub>    Measured L value (H)

## Relative accuracy

Relative accuracy includes stability, temperature coefficient, linearity, repeatability, and calibration interpolation error. Relative accuracy is specified when all of the following conditions are satisfied:

- Warm-up time: 30 minutes
- Test cable length: 0 m, 1 m, 2 m, or 4 m (Keysight Technologies, Inc. 16048A/D/E)
- A “Signal Source Overload” warning does not appear. When the test signal current exceeds a value in table 11 below, a “Signal Source Overload” warning appears.

Test signal voltage	Test frequency	Condition <sup>1</sup>
≤ 2 Vrms	–	–
> 2 Vrms	≤ 1 MHz	The smaller value of either 110 mA or 130 mA - 0.0015 × Vac × (Fm / 1 MHz) × (L_cable + 0.5)
	> 1 MHz	70 mA - 0.0015 × Vac × (Fm / 1 MHz) × (L_cable + 0.5)

1. When the calculation result is a negative value, 0 A is applied.

Table 11.

Vac [V]            Test signal voltage  
Fm [Hz]           Test frequency  
L\_cable [m]       Cable length

- OPEN and SHORT corrections have been performed.
- Bias current isolation: Off
- The DC bias current does not exceed a set value within each range of the DC bias current
- The optimum impedance range is selected by matching the impedance of DUT to the effective measuring range.

|Z|, |Y|, L, C, R, X, G, and B accuracy (L, C, X, and B accuracies apply when  $D_x \leq 0.1$ , R and G accuracies apply  $Q_x \leq 0.1$ )

When  $D_x > 0.1$ , multiply  $A_e$  by  $\sqrt{1+D_x^2}$  for L, C, X, and B accuracies

When  $Q_x > 0.1$ , multiply  $A_e$  by  $\sqrt{1+Q_x^2}$  for R and G accuracies

Relative accuracy  $A_e$  is given as:

**Equation 8.**  $A_e = [A_b + Z_s / |Z_m| \times 100 + Y_o \times |Z_m| \times 100] \times K_t$

$Z_m$  Impedance of DUT  
 $A_b$  Basic accuracy  
 $Z_s$  Short offset  
 $Y_o$  Open offset  
 $K_t$  Temperature coefficient

### D accuracy

D accuracy  $D_e$  is given as - when  $D_x \leq 0.1$

**Equation 9.**  $D_e = \pm A_e / 100$

$D_x$  Measured D value  
 $A_e$  Relative accuracies of  $|Z|$ ,  $|Y|$ , L, C, R, X, G, and B

When  $0.1 < D_x \leq 1$ , multiply  $D_e$  by  $(1 + D_x)$

### Q accuracy (when $Q \times D_e < 1$ )

Q accuracy  $Q_e$  is given as:

**Equation 10.** 
$$Q_e = \pm \frac{(Q_x^2 \times D_e)}{(1 \mp Q_x \times D_e)}$$

$Q_x$  Measured Q value  
 $D_e$  Relative D accuracy

### $\theta$ accuracy

$\theta$  accuracy  $\theta_e$  is given as:

**Equation 11.** 
$$\theta_e = \frac{180 \times A_e}{\pi \times 100} \text{ (deg)}$$

$A_e$  Relative accuracies of  $|Z|$ ,  $|Y|$ , L, C, R, X, G, and B

G accuracy (when  $Dx \leq 0.1$ )

G accuracy  $G_e$  is given as:

**Equation 12.**  $G_e = Bx \times D_e$  (S)

$$Bx = 2\pi f Cx = \frac{1}{2\pi f Lx}$$

- Ge Relative G accuracy
- Dx Measured D value
- Bx Measured B value
- De Relative D accuracy
- f Test frequency (Hz)
- Cx Measured C value (F)
- Lx Measured L value (H)

Rp accuracy (when  $Dx \leq 0.1$ )

Rp accuracy  $R_{pe}$  is given as:

**Equation 13.**  $R_{pe} = \pm \frac{R_{px} \times D_e}{Dx \pm D_e}$  ( $\Omega$ )

- Rpe Relative Rp accuracy
- Rpx Measured Rp value ( $\Omega$ )
- Dx Measured D value
- De Relative D accuracy

Rs accuracy (when  $Dx \leq 0.1$ )

Rs accuracy  $R_{se}$  is given as:

**Equation 14.**  $R_{se} = Xx \times D_e$  ( $\Omega$ )

$$Xx = \frac{1}{2\pi f Cx} = 2\pi f Lx$$

- Rse Relative Rs accuracy
- Dx Measured D value
- Xx Measured X value ( $\Omega$ )
- De Relative D accuracy
- f Test frequency (Hz)
- Cx Measured C value (F)
- Lx Measured L value (H)

## Example of C-D accuracy calculation

### Measurement conditions

**Test frequency:** 1 kHz  
**Measured C value:** 100 nF  
**Test signal voltage:** 1 Vrms  
**Measurement time mode:** Medium  
**Measurement temperature:** 23°C

$$A_b = 0.05\%$$

$$|Z_m| = 1 / (2\pi \times 1 \times 10^3 \times 100 \times 10^{-9}) = 1590 \Omega$$

$$Z_s = 0.6 \text{ m}\Omega \times (1 + 0.400/1) \times (1 + \sqrt{(1000/1000)}) = 1.68 \text{ m}\Omega$$

$$Y_o = 0.5 \text{ nS} \times (1 + 0.100/1) \times (1 + \sqrt{(100/1000)}) = 0.72 \text{ nS}$$

$$C \text{ accuracy: } A_e = [0.05 + 1.68 \text{ m}/1590 \times 100 + 0.72 \text{ n} \times 1590 \times 100] \times 1 = 0.05\%$$

$$D \text{ accuracy: } D_e = 0.05/100 = 0.0005$$

## Basic accuracy

Basic accuracy  $A_b$  is given from Table 12, 13, 14 and 15.

Test frequency [Hz]	Test signal voltage				
	5 mVrms ≤ - < 50 mVrms	50 mVrms ≤ - < 0.3 Vrms	0.3 Vrms ≤ - ≤ 1 Vrms	1 Vrms < - ≤ 10 Vrms	10 Vrms < - ≤ 20 Vrms
20 ≤ - < 125	(0.6%) × (50 mVrms/Vs)	0.60%	0.30%	0.30%	0.30%
125 ≤ - ≤ 1 M	(0.2%) × (50 mVrms/Vs)	0.20%	0.10%	0.15%	0.15%
1 M < - ≤ 2 M	(0.4%) × (50 mVrms/Vs)	0.40%	0.20%	0.30%	0.30%

Table 12. Measurement time mode = SHORT

Test frequency [Hz]	Test signal voltage				
	5 mVrms ≤ - < 30 mVrms	30 mVrms ≤ - < 0.3 Vrms	0.3 Vrms ≤ - ≤ 1 Vrms	1 Vrms < - ≤ 10 Vrms	10 Vrms < - ≤ 20 Vrms
20 ≤ - < 100	(0.25%) × (30 mVrms/Vs)	0.25%	0.10%	0.15%	0.15%
100 ≤ - ≤ 1 M	(0.1%) × (30 mVrms/Vs)	0.10%	0.05%	0.10%	0.15%
1 M < - ≤ 2 M	(0.2%) × (30 mVrms/Vs)	0.20%	0.10%	0.20%	0.30%

Table 13. Measurement time mode = MED, LONG

Vs [Vrms] Test signal voltage

### Effect by impedance of DUT

Test frequency [Hz]	Impedance of DUT	
	1.08 Ω ≤  Zx  < 30 Ω	Zx  < 1.08 Ω
20 ≤ - ≤ 1 M	0.05%	0.10%
1 M < - ≤ 2 M	0.10%	0.20%

Table 14. For impedance of DUT below 30 Ω, the following value is added.

Test frequency [Hz]	Impedance of DUT	
	9.2 kΩ <  Zx  ≤ 92 kΩ	92 kΩ <  Zx
10 k ≤ - ≤ 100 k	0%	0.05%
100 k < - ≤ 1 M	0.05%	0.05%
1 M < - ≤ 2 M	0.10%	0.10%

Table 15. For impedance of DUT over 9.2 k Ω, the following value is added.

### Effect of cable extension

When the cable is extended, the following element is added per one meter.

$$0.015 \% \times (Fm/1 \text{ MHz})^2 \times (L\_cable)^2$$

Fm [Hz] Test frequency

L\_cable [m] Cable length

## Short offset Zs

Test frequency [Hz]	Measurement time mode	
	SHORT	MED, LONG
20 - 2 M	$2.5 \text{ m}\Omega \times (1 + 0.400/V_s) \times (1 + \sqrt{(1000/F_m)})$	$0.6 \text{ m}\Omega \times (1 + 0.400/V_s) \times (1 + \sqrt{(1000/F_m)})$

Table 16. Impedance of DUT > 1.08 Ω

Test frequency [Hz]	Measurement time mode	
	SHORT	MED, LONG
20 - 2 M	$1 \text{ m}\Omega \times (1 + 1/V_s) \times (1 + \sqrt{(1000/F_m)})$	$0.2 \text{ m}\Omega \times (1 + 1/V_s) \times (1 + \sqrt{(1000/F_m)})$

Table 17. Impedance of DUT ≤ 1.08 Ω

Vs [Vrms]      Test signal voltage  
 Fm [Hz]        Test frequency

## Effect of cable extension (Short offset)

Test frequency [Hz]	Cable length			
	0 m	1 m	2 m	4 m
20 ≤ - ≤ 1 M	0	0.25 mΩ	0.5 mΩ	1 mΩ
1 M < - ≤ 2 M	0	1 mΩ	2 mΩ	4 mΩ

Table 18. When the cable is extended, the following value is added to Zs (independent of the measurement time mode).

## Open offset $Y_o$

Test frequency [Hz]	Measurement time mode	
	SHORT	MED, LONG
$20 \leq f < 100 \text{ k}$	$2 \text{ nS} \times (1 + 0.100/V_s) \times (1 + \sqrt{(100/F_m)})$	$0.5 \text{ nS} \times (1 + 0.100/V_s) \times (1 + \sqrt{(100/F_m)})$
$100 \text{ k} < f < 1 \text{ M}$	$20 \text{ nS} \times (1 + 0.100/V_s)$	$5 \text{ nS} \times (1 + 0.100/V_s)$
$1 \text{ M} < f < 2 \text{ M}$	$40 \text{ nS} \times (1 + 0.100/V_s)$	$10 \text{ nS} \times (1 + 0.100/V_s)$

Table 19. Test signal voltage  $\leq 2.0 \text{ V}_{\text{rms}}$

Test frequency [Hz]	Measurement time mode	
	SHORT	MED, LONG
$20 \leq f < 100 \text{ k}$	$2 \text{ nS} \times (1 + 2/V_s) \times (1 + \sqrt{(100/F_m)})$	$0.5 \text{ nS} \times (1 + 2/V_s) \times (1 + \sqrt{(100/F_m)})$
$100 \text{ k} < f < 1 \text{ M}$	$20 \text{ nS} \times (1 + 2/V_s)$	$5 \text{ nS} \times (1 + 2/V_s)$
$1 \text{ M} < f < 2 \text{ M}$	$40 \text{ nS} \times (1 + 2/V_s)$	$10 \text{ nS} \times (1 + 2/V_s)$

Table 20. Test signal voltage  $> 2.0 \text{ V}_{\text{rms}}$

$V_s$  [V<sub>rms</sub>]      Test signal voltage  
 $F_m$  [Hz]        Test frequency

### Note

The Open Offset may become three times greater in the ranges of 40 to 70 kHz and 80 to 100 kHz due to residual response.

## Effect of cable length

Test frequency [Hz]	Cable length			
	0 m	1 m	2 m	4 m
$100 \leq f < 100 \text{ k}$	1	$1 + 5 \times F_m/1 \text{ MHz}$	$1 + 10 \times F_m/1 \text{ MHz}$	$1 + 20 \times F_m/1 \text{ MHz}$
$100 \text{ k} \leq f < 1 \text{ M}$	1	$1 + 0.5 \times F_m/1 \text{ MHz}$	$1 + 1 \times F_m/1 \text{ MHz}$	$1 + 2 \times F_m/1 \text{ MHz}$
$1 \text{ M} < f < 2 \text{ M}$	1	$1 + 1 \times F_m/1 \text{ MHz}$	$1 + 2 \times F_m/1 \text{ MHz}$	$1 + 4 \times F_m/1 \text{ MHz}$

Table 21. When the cable is extended, multiply  $Y_o$  by the following factor.

$F_m$  [Hz]        Test frequency



## Temperature factor Kt

Temperature [°C]	Kt
$0 \leq - < 18$	4
$18 \leq - \leq 28$	1
$28 < - \leq 55$	4

Table 22. The temperature factor Kt is given below.

## Calibration accuracy Acal

Calibration accuracy Acal is given below.

For impedance of DUT or test frequency on the boundary line, apply the smaller value.

	Test frequency [Hz]					
	20 - 1 k	1 k - 10 k	10 k - 100 k	100 k - 300 k	300 k - 1 M	1 M - 2 M
Z  [%]	0.03	0.05	0.05	$0.05 + 5 \times 10^{-5} F_m$	$0.05 + 5 \times 10^{-5} F_m$	$0.1 + 1 \times 10^{-4} F_m$
$\theta$ [radian]	$1 \times 10^{-4}$	$2 \times 10^{-4}$	$3 \times 10^{-4}$	$3 \times 10^{-4} + 2 \times 10^{-7} F_m$	$3 \times 10^{-4} + 2 \times 10^{-7} F_m$	$6 \times 10^{-4} + 4 \times 10^{-7} F_m$

Table 23. Impedance range = 0.1, 1, 10  $\Omega$

	Test frequency [Hz]					
	20 - 1 k	1 k - 10 k	10 k - 100 k	100 k - 300 k	300 k - 1 M	1 M - 2 M
Z  [%]	0.03	0.05	0.05	$0.05 + 5 \times 10^{-5} F_m$	$0.05 + 5 \times 10^{-5} F_m$	$0.1 + 1 \times 10^{-4} F_m$
$\theta$ [radian]	$1 \times 10^{-4}$	$2 \times 10^{-4}$	$3 \times 10^{-4}$	$3 \times 10^{-4}$	$3 \times 10^{-4}$	$6 \times 10^{-4}$

Table 24. Impedance range = 100  $\Omega$

	Test frequency [Hz]					
	20 - 1 k	1 k - 10 k	10 k -100 k	100 k - 300 k	300 k - 1 M	1 M - 2 M
Z  [%]	0.03	0.03	0.05	0.05	0.05	0.1
$\theta$ [radian]	$1 \times 10^{-4}$	$1 \times 10^{-4}$	$3 \times 10^{-4}$	$3 \times 10^{-4}$	$3 \times 10^{-4}$	$6 \times 10^{-4}$

Table 25. Impedance range = 300, 1 k $\Omega$

	Test frequency [Hz]					
	20 - 1 k	1 k - 10 k	10 k -100 k	100 k - 300 k	300 k - 1 M	1 M - 2 M
Z  [%]	0.03 + $1 \times 10^{-4} F_m$	0.03 + $1 \times 10^{-4} F_m$	0.03 + $1 \times 10^{-4} F_m$	0.03 + $1 \times 10^{-4} F_m$	0.03 + $1 \times 10^{-4} F_m$	0.06 + $2 \times 10^{-4} F_m$
$\theta$ [radian]	$(100 + 2.5 F_m) \times 10^{-6}$	$(100 + 2.5 F_m) \times 10^{-6}$	$(100 + 2.5 F_m) \times 10^{-6}$	$(100 + 2.5 F_m) \times 10^{-6}$	$(100 + 2.5 F_m) \times 10^{-6}$	$(200 + 5 F_m) \times 10^{-6}$

Table 26. Impedance range = 3 k, 10 k $\Omega$

	Test frequency [Hz]					
	20 - 1 k	1 k - 10 k	10 k -100 k	100 k - 300 k	300 k - 1 M	1 M - 2 M
Z  [%]	0.03 + $1 \times 10^{-3} F_m$	0.03 + $1 \times 10^{-3} F_m$	0.03 + $1 \times 10^{-3} F_m$	0.03 + $1 \times 10^{-3} F_m$	0.03 + $1 \times 10^{-4} F_m$	0.06 + $2 \times 10^{-4} F_m$
$\theta$ [radian]	$(100 + 20 F_m) \times 10^{-6}$	$(100 + 20 F_m) \times 10^{-6}$	$(100 + 20 F_m) \times 10^{-6}$	$(100 + 20 F_m) \times 10^{-6}$	$(100 + 2.5 F_m) \times 10^{-6}$	$(200 + 5 F_m) \times 10^{-6}$

Table 27. Impedance range = 30 k, 100 k $\Omega$

Fm[kHz]      Test frequency

## Measurement accuracy

The impedance measurement calculation example below is the result of absolute measurement accuracy.

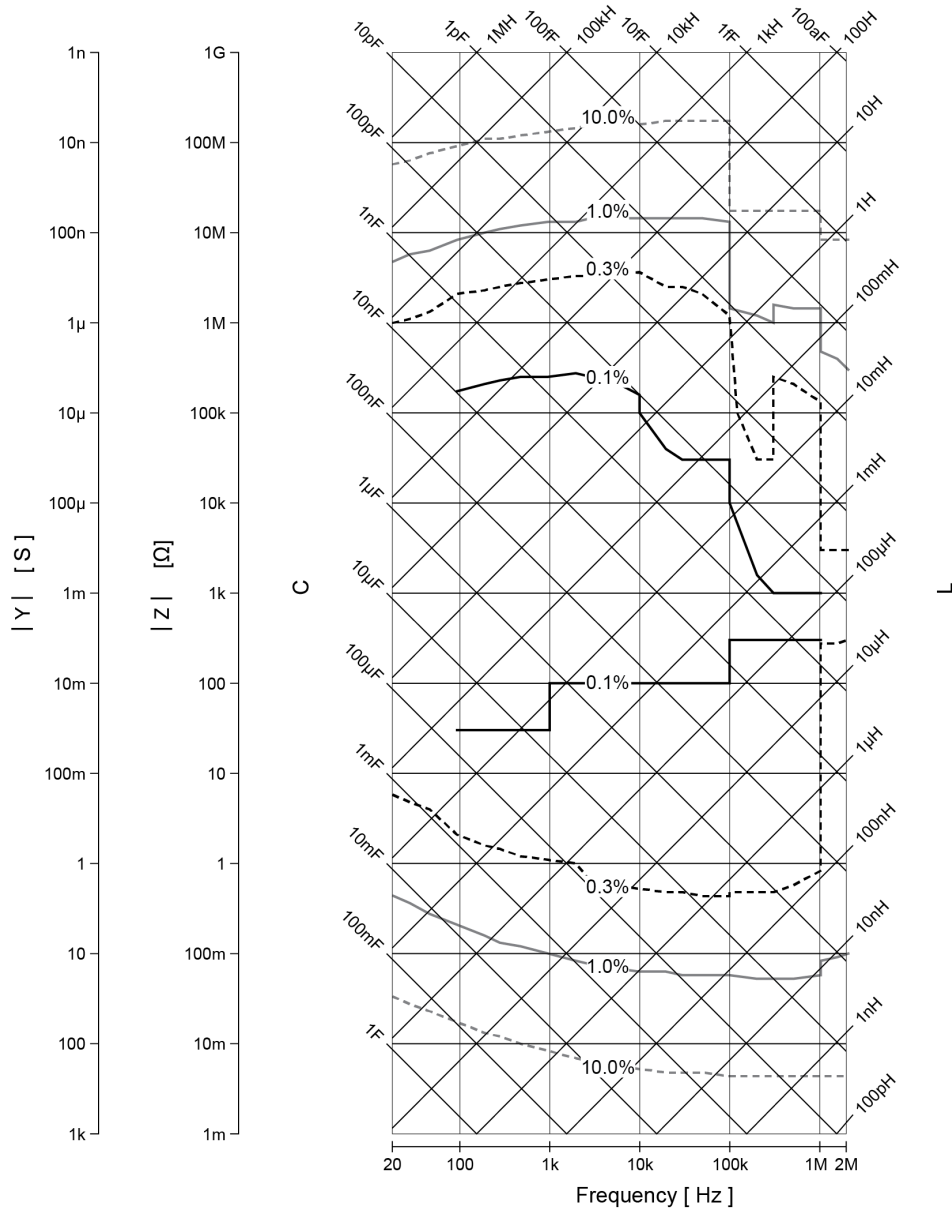

Figure 1. Impedance measurement accuracy (Test signal voltage = 1 Vrms, cable length = 0 m, measurement time mode = MED)

## Compensation function

Type of compensation	Description
OPEN compensation	Compensates errors caused by the stray admittance (C, G) of the test fixture.
SHORT compensation	Compensates errors caused by the residual impedance (L, R) of the test fixture.
LOAD compensation	Compensates errors between the actual measured value and a known standard value under the measurement conditions desired by the user.

Table 28. The E4980A provides three types of compensation functions: OPEN compensation, SHORT compensation, and LOAD compensation.

### List sweep

**Points:** There is a maximum of 201 points.

**First sweep parameter (primary parameter):** Test frequency, test signal voltage, test signal current, test signal voltage of DC bias signal, test signal current of DC bias signal, DC source voltage.

**Second sweep parameter (secondary parameter):** None, impedance range, test frequency, test signal voltage, test signal current, test signal voltage of DC bias signal, test signal current of DC bias signal, DC source voltage

#### Note

A parameter selected for one of the two parameters cannot be selected for the other parameter. It is not possible to set up a combination of test signal voltage and test signal current or one of test signal voltage of DC bias signal and test signal current of DC bias.

The secondary parameter can be set only with SCPI commands.

### Trigger mode

**Sequential mode:** When the E4980A is triggered once, the device is measured at all sweep points. /EOM/INDEX is output only once.

**Step mode:** The sweep point is incremented each time the E4980A is triggered. /EOM/INDEX is output at each point, but the result of the comparator function of the list sweep is available only after the last /EOM is output.

**Comparator function of list sweep:** The comparator function enables setting one pair of lower and upper limits for each measurement point.

You can select from: Judge with the first sweep parameter/Judge with the second parameter/Not used for each pair of limits.

**Time stamp function:** In the sequential mode, it is possible to record the measurement starting time at each measurement point by defining the time when FW detects a trigger as 0 and obtain it later with the SCPI command.

## Comparator function

**Bin sort:** The primary parameter can be sorted into 9 BINS, OUT\_OF\_BINS, AUX\_BIN, and LOW\_C\_REJECT. The secondary parameter can be sorted into HIGH, IN, and LOW. The sequential mode and tolerance mode can be selected as the sorting mode.

**Limit setup:** Absolute value, deviation value, and % deviation value can be used for setup.

**BIN count:** Countable from 0 to 999999.

## DC bias signal

Range	0 V to +2 V
Resolution	0 V / 1.5 V / 2 V only
Accuracy	0.1% + 2 mV (23°C ± 5°C) (0.1% + 2 mV) × 4 (0 to 18°C or 28 to 55°C)

Table 29. Test signal voltage

**Output impedance:** 100 Ω (nominal)

## Measurement assistance functions

**Data buffer function:** Up to 201 measurement results can be read out in a batch.

### Save/Recall function:

- Up to 10 setup conditions can be written to/read from the built-in non-volatile memory.
- Up to 10 setup conditions can be written to/read from the USB memory.
- Auto recall function can be performed when the setting conditions are written to Register 10 of the USB memory.

**Key lock function:** The front panel keys can be locked.

**GPIB:** 24-pin D-Sub (Type D-24), female; complies with IEEE488.1, 2 and SCPI

**USB host port:** Universal serial bus jack, type-A (4 contact positions, contact 1 is on your left), female (for connection to USB memory only).

**USB interface port:** Universal serial bus jack, type mini-B (4 contact positions); complies with USBTMC-USB488 and USB 2.0; female; for connection to the external controller.

**USBTMC:** Abbreviation for USB Test & Measurement Class

**LAN:** 10/100 BaseT Ethernet, 8 pins (two speed options)

**LXI Compliance:** Class C (only applies to units with firmware revision A.02.00 or later)

Note

This note is for the E4980A/E4980AL units with firmware A.xx.xx.

The following USB memory can be used.

Complies with USB 1.1; mass storage class, FAT16/FAT32 format; maximum consumption current is below 500 mA.

Recommended USB memory: 4 GB USB Flash memory (Keysight PN 1819-0637) and 16GB USB Flash memory (Keysight PN 1819-1235).

Use the recommended USB memory device exclusively for the E4980A/E4980AL, otherwise, previously saved data may be cleared.

If you use a USB memory other than the recommended device, data may not be saved or recalled normally.

Keysight will NOT be responsible for data loss in the USB memory caused by using the E4980A/E4980AL.

## Options

### Frequency options

E4980A	20 Hz to 2 MHz
E4980AL-032	20 Hz to 300 kHz
E4980AL-052	20 Hz to 500 kHz
E4980AL-102	20 Hz to 1 MHz

Note

Option xxx is described as E4980A-xxx in the order information

Options	E4980A	E4980AL
Power and DC bias enhancement (001)	Installable	Not installable
DCR measurement (200)	Installable <sup>1</sup>	Not installable <sup>2</sup>
Handler interface (201)	Installable	Installable
Scanner interface (301)	Installable	Installable

1. Mandatory option

2. DCR measurement function is equipped by default.

Table 30. Installable options

## Interface options

### Option 201 (Handler interface)

Adds handler interface.

### Option 301 (Scanner interface)

Adds scanner interface.

### Option 710 (No interface)

An option with no interface.

Up to 2 interface options can be installed in the interface connector on the rear panel.

When no interface is installed, two of the option 710 are installed. When one interface is installed, the option number of its interface and one option 710 are installed.

## Other options

### Option 001 (Power and DC Bias enhancement)

Increases test signal voltage and adds the variable DC bias voltage.

### Option 007 (Standard model)

Upgrades the entry model to the standard (only available in E4980AU).

Note

Option 007 can be installed only in the E4980A with option 005.

### Option 200 (DCR measurement)

Adds DCR measurement

Note

E4980A-200/001 and E4980AL-032/052/102 supports DCR measurement function.

## Power and DC bias enhancement specification

Increases test signal voltage and adds the variable DC bias voltage function. The Vdc-I<sub>dc</sub> measurement function is available when the option 001 is installed.

## Measurement parameters

The following parameters can be used.

- L<sub>p</sub>-R<sub>dc</sub>
- L<sub>s</sub>-R<sub>dc</sub>
- V<sub>dc</sub>-I<sub>dc</sub>

where

R<sub>dc</sub> Direct-current resistance (DCR)

V<sub>dc</sub> Direct-current voltage

I<sub>dc</sub> Direct-current electricity

## Test signal

### Signal level

Range		0 Vrms to 20 Vrms (test frequency $\leq$ 1 MHz) 0 Vrms to 15 Vrms (test frequency $>$ 1 MHz)
Resolution		100 $\mu$ Vrms (0 Vrms $\leq$ - $\leq$ 0.2 Vrms) 200 $\mu$ Vrms (0.2 Vrms $<$ - $\leq$ 0.5 Vrms) 500 $\mu$ Vrms (0.5 Vrms $<$ - $\leq$ 1 Vrms) 1 mVrms (1 Vrms $<$ - $\leq$ 2 Vrms) 2 mVrms (2 Vrms $<$ - $\leq$ 5 Vrms) 5 mVrms (5 Vrms $<$ - $\leq$ 10 Vrms) 10 mVrms (10 Vrms $<$ - $\leq$ 20 Vrms)
Setup accuracy	Normal	$\pm(10\% + 1 \text{ mVrms})$ (test signal voltage $\leq$ 2 Vrms) (test frequency $\leq$ 1 MHz : spec., test frequency $>$ 1 MHz : typ.)
		$\pm(10\% + 10 \text{ mVrms})$ (Test frequency $\leq$ 300 kHz, test signal voltage $>$ 2 Vrms) (spec.)
		$\pm(15\% + 20 \text{ mVrms})$ (test frequency $>$ 300 kHz, test signal voltage $>$ 2 Vrms) (test frequency $\leq$ 1 MHz : spec., test frequency $>$ 1 MHz : typ.)
	Constant <sup>1</sup>	$\pm(6\% + 1 \text{ mVrms})$ (test signal voltage $\leq$ 2 Vrms) (test frequency $\leq$ 1 MHz : spec., test frequency $>$ 1 MHz : typ.)
		$\pm(6\% + 10 \text{ mVrms})$ (test frequency $\leq$ 300 kHz, test signal voltage $>$ 2 Vrms) (spec.)
		$\pm(12\% + 20 \text{ mVrms})$ (test frequency $>$ 300 kHz, test signal voltage $>$ 2 Vrms) (test frequency $\leq$ 1 MHz : spec., test frequency $>$ 1 MHz : typ.)

1. When auto level control function is on.

Table 31. Test signal voltage

Range		0 Arms - 100 mArms
Resolution		1 $\mu$ Arms (0 Arms $\leq$ - $\leq$ 2 mArms) 2 $\mu$ Arms (2 mArms $<$ - $\leq$ 5 mArms) 5 $\mu$ Arms (5 mArms $<$ - $\leq$ 10 mArms) 10 $\mu$ Arms (10 mArms $<$ - $\leq$ 20 mArms) 20 $\mu$ Arms (20 mArms $<$ - $\leq$ 50 mArms) 50 $\mu$ Arms (50 mArms $<$ - $\leq$ 100 mArms)
Setup accuracy	Normal	$\pm(10\% + 10 \mu\text{Arms})$ (test signal voltage $\leq$ 20 mArms) (test frequency $\leq$ 1 MHz : spec., test frequency $>$ 1 MHz : typ.)
		$\pm(10\% + 100 \mu\text{Arms})$ (test frequency $\leq$ 300 kHz, test signal current $>$ 20 mArms) (spec.)



	$\pm(15\% + 200 \mu\text{Arms})$ (test frequency > 300 kHz, test signal voltage > 20 mArms) (test frequency $\leq$ 1 MHz : spec., test frequency > 1 MHz : typ.)
Constant <sup>1</sup>	$\pm(6\% + 10 \mu\text{Arms})$ (test signal voltage $\leq$ 20 mArms) (test frequency $\leq$ 1 MHz : spec., test frequency > 1 MHz : typ.)
	$\pm(6\% + 100 \mu\text{Arms})$ (test frequency $\leq$ 300 kHz, test signal voltage > 20 mArms) (spec.)
	$\pm(12\% + 200 \mu\text{Arms})$ (test frequency > 300 kHz, test signal voltage > 20 mArms) (test frequency $\leq$ 1 MHz : spec., test frequency > 1 MHz : typ.)

Table 32. Test signal current

### Test signal level monitor function

- Test signal voltage and test signal current can be monitored.
- Level monitor accuracy:

Test signal voltage <sup>2</sup>	Test frequency	Specification
5 mVrms to 2 Vrms	$\leq$ 1 MHz	$\pm(3\%$ of reading value + 0.5 mVrms)
	> 1MHz	$\pm(6\%$ of reading value + 1 mVrms)
> 2 Vrms	$\leq$ 300 kHz	$\pm(3\%$ of reading value + 5 mVrms)
	> 300 kHz	$\pm(6\%$ of reading value + 10 mVrms) <sup>3</sup>

Table 33. Test signal voltage monitor accuracy (Vac)

Test signal current <sup>2</sup>	Test frequency	Specification
50 $\mu$ Arms to 20 mArms	$\leq$ 1 MHz	$\pm(3\%$ of reading value + 5 $\mu$ Arms)
	> 1MHz	$\pm(6\%$ of reading value + 10 $\mu$ Arms)
> 20 mArms	$\leq$ 300 kHz	$\pm(3\%$ of reading value + 50 $\mu$ Arms)
	> 300 kHz	$\pm(6\%$ of reading value + 100 $\mu$ Arms)

Table 34. Test signal current monitor accuracy (Iac)

1. When auto level control function is on.
2. This is not an output value but a displayed test signal level
3. Typ. when test frequency is > 1 MHz with test signal voltage > 10 Vrms.

## DC bias signal

Range		-40 V to +40 V
Resolution		Setup resolution: 100 $\mu$ V, effective resolution: 330 $\mu$ V $\pm$ (0 V $\leq$ - $\leq$ 5 V) 1 mV $\pm$ (5 V < - $\leq$ 10 V) 2 mV $\pm$ (10 V < - $\leq$ 20 V) 5 mV $\pm$ (20 V < - $\leq$ 40 V)
Accuracy	test signal voltage $\leq$ 2 Vrms	0.1% + 2 mV (23°C $\pm$ 5°C) (0.1% + 2 mV) $\times$ 4 (0 to 18°C or 28 to 55°C)
	test signal voltage > 2 Vrms	0.1 % + 4 mV (23°C $\pm$ 5°C) (0.1% + 4 mV) $\times$ 4 (0 to 18°C or 28 to 55°C)

Table 35. Test signal voltage

Range		-100 mA - 100 mA
Resolution		Setup resolution: 1 $\mu$ A, effective resolution: 3.3 $\mu$ A $\pm$ (0 A $\leq$ - $\leq$ 50 mA) 10 $\mu$ A $\pm$ (50 mA < - $\leq$ 100 mA)

Table 36. Test signal current

### DC bias voltage level monitor Vdc

$$(0.5\% \text{ of reading value} + 60 \text{ mV}) \times Kt$$

When using Vdc-Idc measurement: (spec.)

When using level monitor: (typ.)

Kt      Temperature coefficient

### DC bias current level monitor Idc

$$(A [\%] \text{ of the measurement value} + B [A]) \times Kt$$

When using Vdc-Idc measurement: (spec.)

When using level monitor: (typ.)

A [%]    When the measurement time mode is SHORT: 2%  
          When the measurement time mode is MED or LONG: 1%

B [A] given below

Kt Temperature coefficient

When the measurement mode is SHORT, double the following value.

DC bias current range	Impedance range [ $\Omega$ ]				
	< 100	100	300, 1 k	3 k, 10 k	30k, 100 k
20 $\mu$ A	150 $\mu$ A	30 $\mu$ A	3 $\mu$ A	300 nA	45 nA
200 $\mu$ A	150 $\mu$ A	30 $\mu$ A	3 $\mu$ A	300 nA	300 nA
2 mA	150 $\mu$ A	30 $\mu$ A	3 $\mu$ A	3 $\mu$ A	3 $\mu$ A
20 mA	150 $\mu$ A	30 $\mu$ A	30 $\mu$ A	30 $\mu$ A	30 $\mu$ A
100 mA	150 $\mu$ A	150 $\mu$ A	150 $\mu$ A	150 $\mu$ A	150 $\mu$ A

Table 37. Test signal voltage  $\leq 0.2$  Vrms (measurement time mode = MED, LONG)

DC bias current range	Impedance range [ $\Omega$ ]				
	< 100	100, 300	1k, 3 k	10k, 30 k	100 k
20 $\mu$ A	150 $\mu$ A	30 $\mu$ A	3 $\mu$ A	300 nA	45 nA
200 $\mu$ A	150 $\mu$ A	30 $\mu$ A	3 $\mu$ A	300 nA	300 nA
2 mA	150 $\mu$ A	30 $\mu$ A	3 $\mu$ A	3 $\mu$ A	3 $\mu$ A
20 mA	150 $\mu$ A	30 $\mu$ A	30 $\mu$ A	30 $\mu$ A	30 $\mu$ A
100 mA	150 $\mu$ A	150 $\mu$ A	150 $\mu$ A	150 $\mu$ A	150 $\mu$ A

Table 38.  $0.2$  Vrms < test signal voltage  $\leq 2$  Vrms (measurement time mode = MED, LONG)

DC bias current range	Impedance range [ $\Omega$ ]			
	$\leq 300$	1 k, 3 k	10k, 30 k	100 k
20 $\mu$ A	150 $\mu$ A	30 $\mu$ A	3 $\mu$ A	300 nA
200 $\mu$ A	150 $\mu$ A	30 $\mu$ A	3 $\mu$ A	300 nA
2 mA	150 $\mu$ A	30 $\mu$ A	3 $\mu$ A	3 $\mu$ A
20 mA	150 $\mu$ A	30 $\mu$ A	30 $\mu$ A	30 $\mu$ A
100 mA	150 $\mu$ A	150 $\mu$ A	150 $\mu$ A	150 $\mu$ A

Table 39. Test signal voltage  $> 2$  Vrms (measurement time mode = MED, LONG)

Input impedance	Conditions
0 $\Omega$	Other than conditions below.
20 $\Omega$	Test signal voltage $\leq 0.2$ Vrms, Impedance range $\geq 3$ k $\Omega$ , DC bias current range $\leq 200$ $\mu$ A
	Test signal voltage $\leq 2$ Vrms, Impedance range $\geq 10$ k $\Omega$ , DC bias current range $\leq 200$ $\mu$ A
	Test signal voltage $> 2$ Vrms, Impedance range = 100 k $\Omega$ , DC bias current range $\leq 200$ $\mu$ A

Table 40. Input impedance (nominal)

### DC source signal

Range	-10 V to 10 V
Resolution	1 mV
Accuracy	0.1% + 3 mV (23°C $\pm$ 5°C) (0.1% + 3 mV) x 4 (0 to 18°C or 28 to 55°C)

Table 41. Test signal voltage

Range	-45 mA to 45 mA (nominal)
-------	---------------------------

Table 42. Test signal current

**Output impedance:** 100  $\Omega$  (nominal)

### DCR measurement specification

DC resistance (Rdc) measurement function is available when either E4980A-001/200 or E4980AL-032/052/102 is installed.

### DC resistance (Rdc) accuracy

Absolute measurement accuracy Aa

Absolute measurement accuracy Aa is given as

**Equation 15.  $A_a = A_e + A_{cal}$**

- A<sub>a</sub> Absolute accuracy (% of reading value)
- A<sub>e</sub> Relative accuracy (% of reading value)
- A<sub>cal</sub> Calibration accuracy

Relative measurement accuracy A<sub>e</sub>

Relative measurement accuracy A<sub>e</sub> is given as

**Equation 16.  $A_e = [A_b + (R_s / |R_m| + G_o \times |R_m|) \times 100] \times K_t$**

- R<sub>m</sub> Measurement value
- A<sub>b</sub> Basic accuracy
- R<sub>s</sub> Short offset [Ω]
- G<sub>o</sub> Open offset [S]
- K<sub>t</sub> Temperature coefficient

Calibration accuracy A<sub>cal</sub>

Calibration accuracy A<sub>cal</sub> is 0.03%.

Basic accuracy A<sub>b</sub>

Measurement time mode	Test signal voltage	
	≤ 2 V <sub>rms</sub>	> 2 V <sub>rms</sub>
SHORT	1.00%	2.00%
MED	0.30%	0.60%

Table 43. Basic accuracy A<sub>b</sub> is given below.

Open offset G<sub>o</sub>

Measurement time mode	Test signal voltage	
	≤ 2 V <sub>rms</sub>	> 2 V <sub>rms</sub>
SHORT	50 nS	500 nS
MED	10 nS	100 nS

Table 44. Open offset G<sub>o</sub> is given below.

## Short offset Rs

Measurement time mode	Test signal voltage	
	$\leq 2 \text{ Vrms}$	$> 2 \text{ Vrms}$
SHORT	25 m $\Omega$	250 m $\Omega$
MED	5 m $\Omega$	50 m $\Omega$

Table 45. Short offset Rs is given below.

## Effect of cable length (Short offset)

Cable length		
1 m	2 m	4 m
0.25 m $\Omega$	0.5 m $\Omega$	1 m $\Omega$

Table 46. The following value is added to Rs when the cable is extended.

## Temperature coefficient Kt

Temperature [ $^{\circ}\text{C}$ ]	Kt
$0 \leq - < 18$	4
$18 \leq - \leq 28$	1
$28 < - \leq 55$	4

Table 47. Temperature coefficient Kt is given below.

## General Specifications

Voltage	90 VAC - 264 VAC
Frequency	47 Hz - 63 Hz
Power consumption	Max. 150 VA

Table 48. Power source

Temperature	0 - 55°C
Humidity ( $\leq 40^\circ\text{C}$ , no condensation)	15% - 85% RH
Altitude	0 m - 2000 m

Table 49. Operating environment

Temperature	-20 - 70°C
Humidity ( $\leq 60^\circ\text{C}$ , no condensation)	0% - 90% RH
Altitude	0 m - 4572 m

Table 50. Storage environment

**Outer dimensions: 375 (width) x 105 (height) x 390 (depth) mm (nominal)**

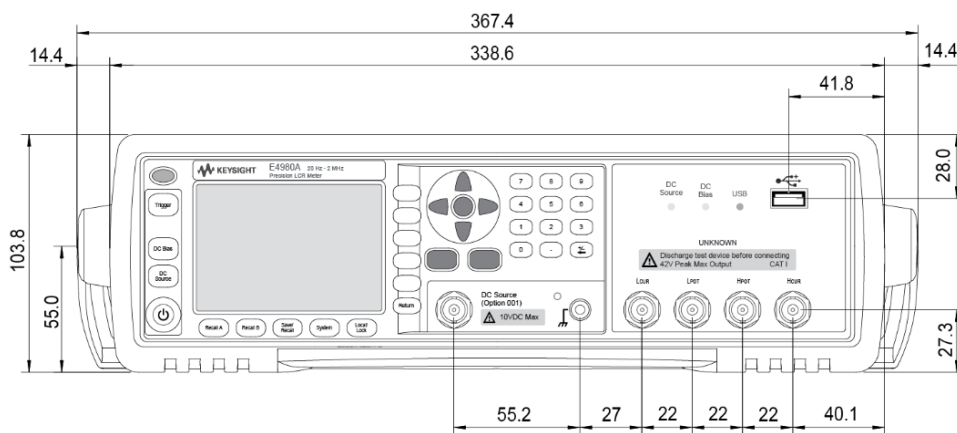

Figure 2. Dimensions (front view, with handle and bumper, in millimeters, nominal)

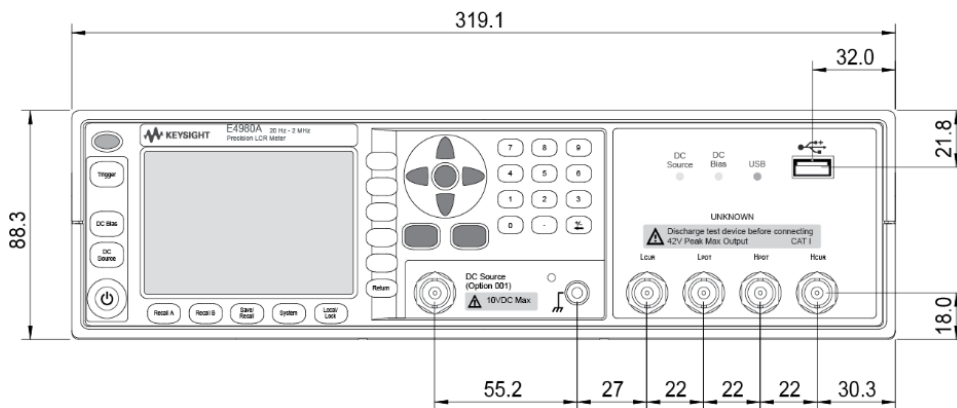

Figure 3. Dimensions (front view, without handle and bumper, in millimeters, nominal)

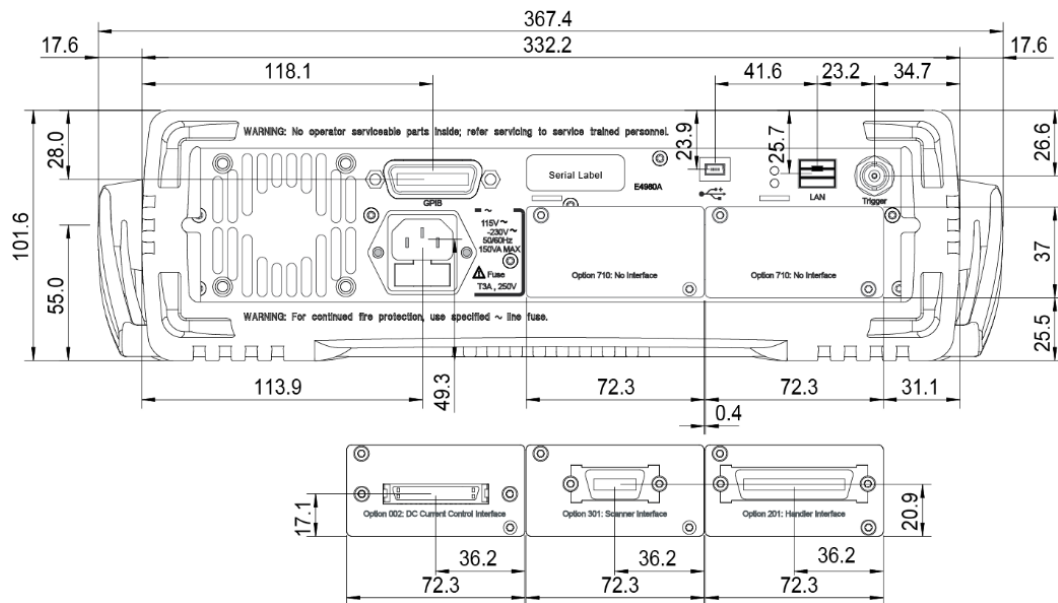

Figure 4. Dimensions (rear view, with handle and bumper, in millimeters, nominal)

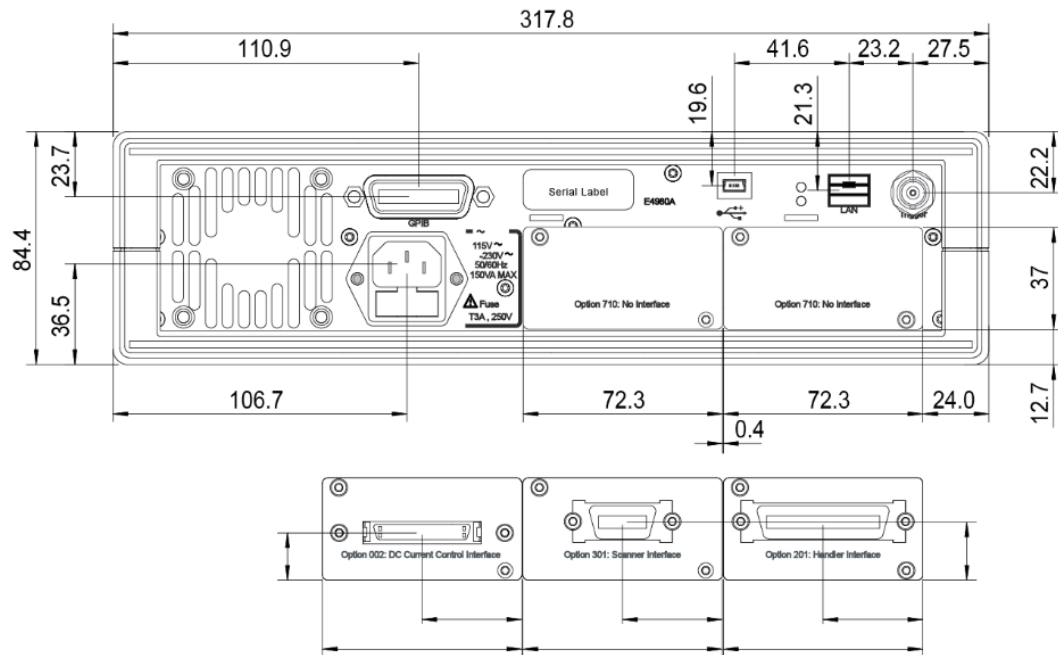

Figure 5. Dimensions (rear view, with handle and bumper, in millimeters, nominal)



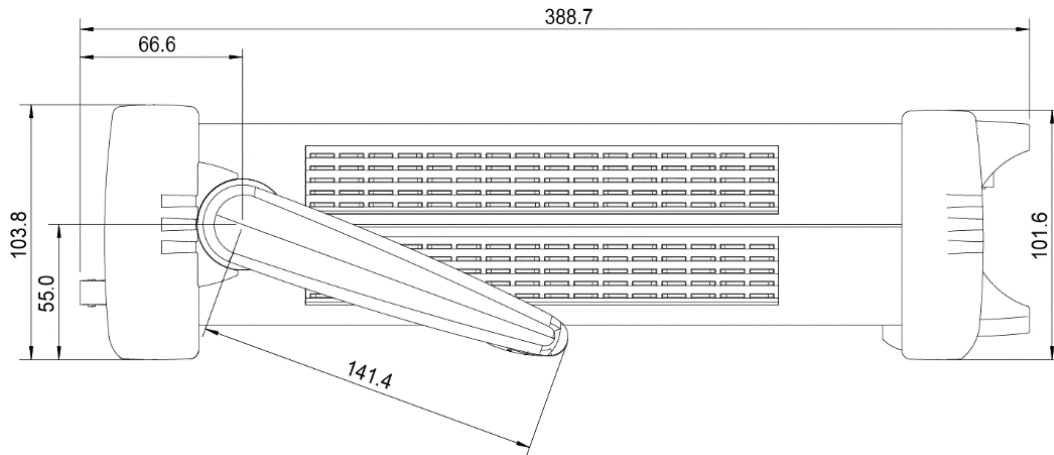

Figure 6. Dimensions (side view, with handle and bumper, in millimeters, nominal)

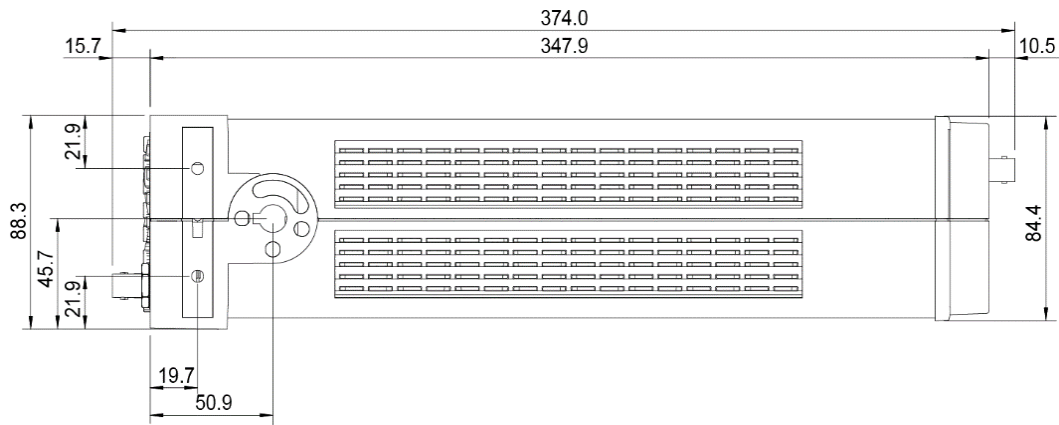

Figure 7. Dimensions (side view, without handle and bumper, in millimeters, nominal)

**Weight:** 5.3 kg (nominal)



**Display:** LCD, 320 × 240 (pixels), RGB color

Note

Effective pixels are more than 99.99%. There may be 0.01% (approx. 7 pixels) or smaller missing pixels or constantly lit pixels, but this is not a malfunction.

The following items can be displayed:

- Measurement value
- Measurement conditions
- Limit value and judgment result of comparator
- List sweep table
- Self-test message

Description	Supplemental Information
EMC	
	<p>European Council Directive 2004/108/EC  IEC 61326-1:2012  EN 61326-1:2013  CISPR 11:2009 +A1:2010  EN 55011: 2009 +A1:2010  Group 1, Class A  IEC 61000-4-2:2008  EN 61000-4-2:2009  4 kV CD / 8 kV AD  IEC 61000-4-3:2006 +A1:2007 +A2:2010  EN 61000-4-3:2006 +A1:2008 +A2:2010  3 V/m, 80-1000 MHz, 1.4 - 2.0 GHz / 1V/m, 2.0 - 2.7 GHz, 80% AM  IEC 61000-4-4:2004 +A1:2010  EN 61000-4-4:2004 +A1:2010  1 kV power lines / 0.5 kV signal lines  IEC 61000-4-5:2005  EN 61000-4-5:2006  0.5 kV line-line / 1 kV line-ground  IEC 61000-4-6:2008  EN 61000-4-6:2009  3 V, 0.15-80 MHz, 80% AM  IEC 61000-4-8:2009  EN 61000-4-8:2010  30A/m, 50/60Hz  IEC 61000-4-11:2004  EN 61000-4-11:2004  0.5-300 cycle, 0% / 70%</p> <p><b>Note:</b>  When tested at 3 V/m according to EN61000-4-3, the measurement accuracy will be within specifications over the full immunity test frequency range except when the meter frequency is identical to the transmitted interference signal test frequency (the frequencies around the carrier frequency and frequencies around the modulation frequency).</p>
ICES/NMB-001	ICES-001:2006 Group 1, Class A
	AS/NZS CISPR11:2004 Group 1, Class A
	KN11, KN61000-6-1 and KN61000-6-2 Group 1, Class A

## Safety



European Council Directive 2006/95/EC  
IEC 61010-1:2001/EN 61010-1:2001  
Measurement Category I, Pollution Degree 2, Indoor Use  
IEC60825-1:1994 Class 1 LED



CAN/CSA C22.2 61010-1-04  
Measurement Category I, Pollution Degree 2, Indoor Use

## Environment

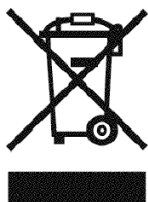

This product complies with the WEEE Directive (2002/96/EC) marking requirements. The affixed label indicates that you must not discard this electrical/electronic product in domestic household waste.

Product Category: With reference to the equipment types in the WEEE Directive Annex I, this product is classed as a "Monitoring and Control instrumentation" product.

## Supplemental Information

### Settling time

Test frequency setting time	Test frequency (Fm)
5 ms	$F_m \geq 1 \text{ kHz}$
12 ms	$1 \text{ kHz} > F_m \geq 250 \text{ Hz}$
22 ms	$250 \text{ Hz} > F_m \geq 60 \text{ Hz}$
42 ms	$60 \text{ Hz} > F_m$

Table 51. Test frequency setting time

Test signal voltage setting time	Test frequency (Fm)
11 ms	$F_m \geq 1 \text{ kHz}$
18 ms	$1 \text{ kHz} > F_m \geq 250 \text{ Hz}$
26 ms	$250 \text{ Hz} > F_m \geq 60 \text{ Hz}$
48 ms	$60 \text{ Hz} > F_m$

Table 52. Test signal voltage setting time

Switching of the impedance range is as follows:  
 $\leq 5$  ms/ range switching

### Measurement circuit protection

The maximum discharge withstand voltage, where the internal circuit remains protected if a charged capacitor is connected to the UNKNOWN terminal, is given below.

Maximum discharge withstand voltage	Range of capacitance value C of DUT
1000 V	$C < 2 \mu\text{F}$
$\sqrt{2/C}$ V	$2 \mu\text{F} \leq C$

Note  
 Discharge capacitors before connecting them to the UNKNOWN terminal or a test fixture to avoid damages to the instrument.

Table 53. Maximum discharge withstand voltage

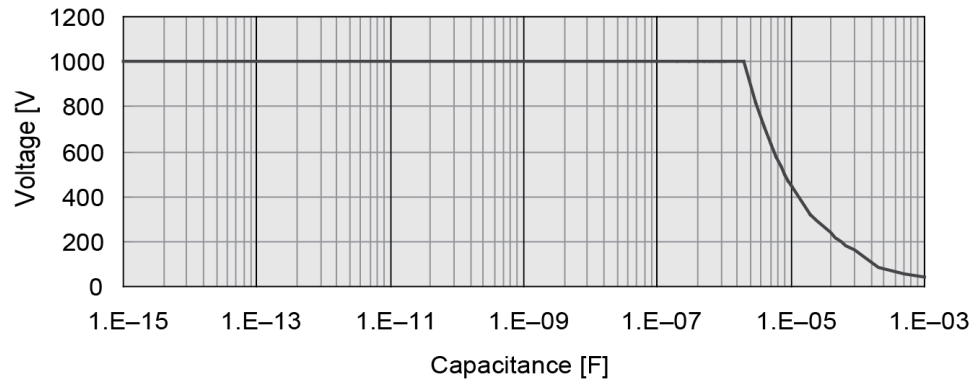

Figure 8. Maximum discharge withstand voltage

### Measurement time

#### Definition

This is the time between the trigger and the end of measurement (EOM) output on the handler interface.

## Conditions

Table 54, 55 and 56 show the measurement time when the following conditions are satisfied:

- Normal impedance measurement other than Ls-Rdc, Lp-Rdc, Vdc-Idc
- Impedance range mode: hold range mode
- DC bias voltage level monitor: OFF
- DC bias current level monitor: OFF
- Trigger delay: 0 s
- Step delay: 0 s
- Calibration data: OFF
- Display mode: blank

	Measurement time mode	Test frequency						
		20 Hz	100 Hz	1 kHz	10 kHz	100 kHz	1 MHz	2 MHz
1	LONG	480	300	240	230	220	220	220
2	MED	380	180	110	92	89	88	88
3	SHORT	330	100	20	7.7	5.7	5.6	5.6

Table 54. E4980A measurement time [ms](DC bias:OFF)

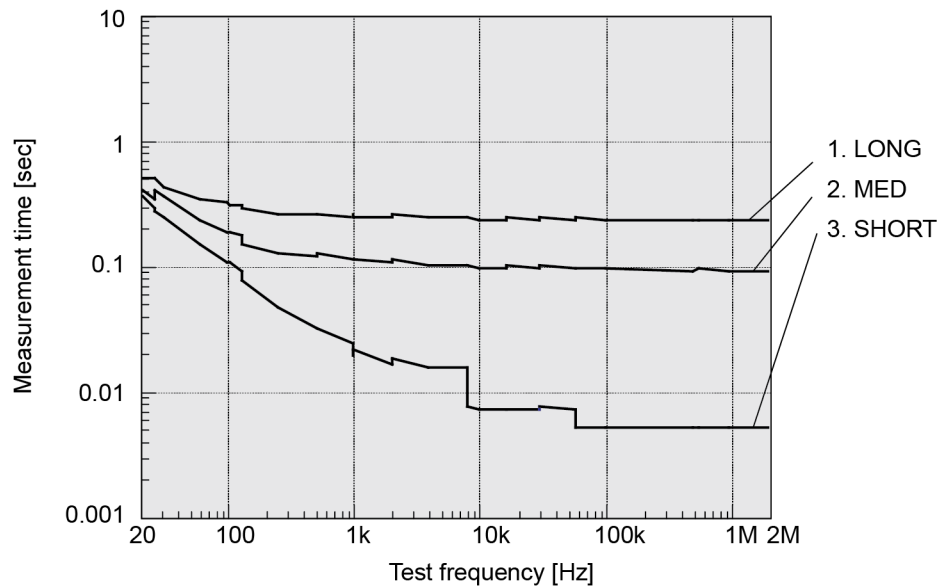

Figure 9. Measurement time (E4980A, DC bias: OFF)

	Measurement time mode	Test frequency						
		20 Hz	100 Hz	1 kHz	10 kHz	100 kHz	1 MHz	2 MHz
1	LONG	1190	650	590	580	570	570	570
2	MED	1150	380	200	180	180	180	180
3	SHORT	1040	240	37	25	23	23	23

Note  
E4980A-005 is obsolete and not available in a new purchase.

Table 55. E4980A-005 measurement time [ms] (DC bias: OFF)

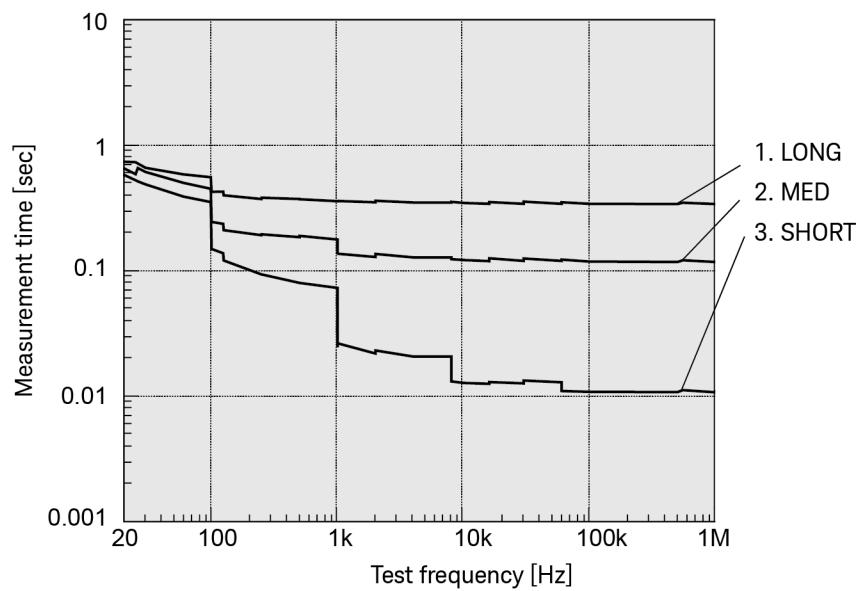

Figure 10. Measurement time (DC bias: OFF, E4980A-005)

	Measurement time mode	Test frequency					
		20 Hz	100 Hz	1 kHz	10 kHz	100 kHz	1 MHz
1	LONG	729	423	363	353	343	343
2	MED	650	250	140	122	119	118
3	SHORT	579	149	26	14	12	12

Table 56. E4980AL measurement time [ms]

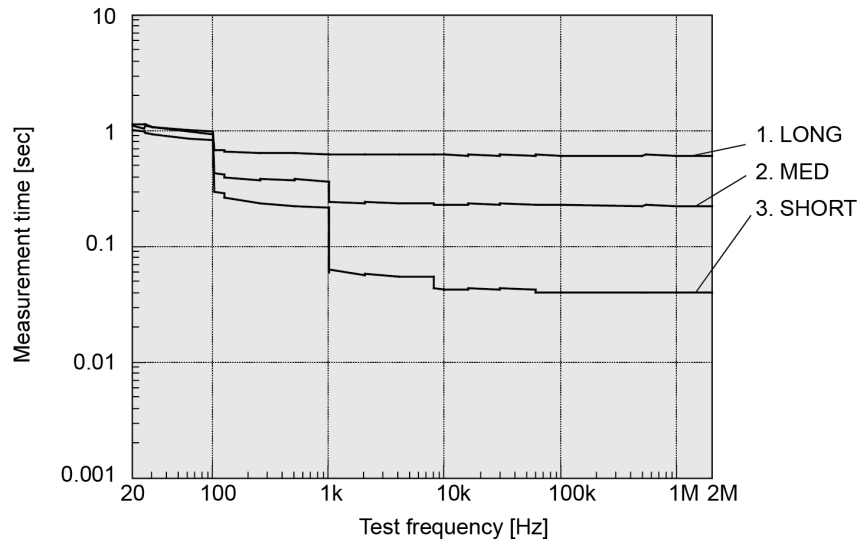

Figure 11. Measurement time (E4980AL)

When DC bias is ON, the following time is added:

Test frequency						
20 Hz	100 Hz	1 kHz	10 kHz	100 kHz	1 MHz	2 MHz
30	30	10	13	2	0.5	0.5

Table 57. Additional time when DC bias is ON [ms]

When the number of averaging increases, the measurement time is given as

**Equation 17.**  $MeasTime + (Ave - 1) \times AveTime$

MeasTime Measurement time calculated based on Table 54, 55 and 56

Ave Number of averaging

AveTime Refer to Table 58

Measurement time mode	Test frequency						
	20 Hz	100 Hz	1 kHz	10 kHz	100 kHz	1 MHz	2 MHz
SHORT	51	11	2.4	2.3	2.3	2.2	2.2
MED	110	81	88	87	85	84	84
LONG	210	210	220	220	220	210	210

Table 58. Additional time per averaging [ms]

Measurement time mode	Test frequency						
	20 Hz	100 Hz	1 kHz	10 kHz	100 kHz	1 MHz	2 MHz
SHORT	210	46	14	14	14	14	14
MED	210	170	170	170	170	170	170
LONG	410	410	410	410	410	410	410

Table 59. Measurement time when Vdc-Idc is selected [ms]

Add the same measurement time per 1 additional average

Additional Measurement time when the Vdc and Idc monitor function is ON. Add SHORT mode of Table 59. When using only Vdc or Idc, add a half of SHORT mode of Table 59.

Measurement time mode	Test frequency						
	20 Hz	100 Hz	1 kHz	10 kHz	100 kHz	1 MHz	2 MHz
SHORT	910	230	43	24	22	22	22
MED	1100	450	300	280	270	270	270
LONG	1400	820	700	670	660	650	650

Table 60. Measurement time when Ls-Rdc or Lp-Rdc is selected [ms]

Add the three times of Table 58 Additional Time per 1 additional average number

## Display time

Except for the case of the DISPLAY BLANK page, the time required to update the display on each page (display time) is as follows. When a screen is changed, drawing time and switching time are added. The measurement display is updated about every 100 ms.

Item	When Vdc, Idc monitor is OFF	When Vdc, Idc monitor is ON
MEAS DISPLAY page drawing time	10 ms	13 ms
MEAS DISPLAY page (large) drawing time	10 ms	13 ms
BIN No. DISPLAY page drawing time	10 ms	13 ms
BIN COUNT DISPLAY page drawing time	10 ms	13 ms
LIST SWEEP DISPLAY page drawing time	40 ms	—
Measurement display switching time	35 ms	—

Table 61. Display time



## Measurement data transfer time

This table shows the measurement data transfer time under the following conditions. The measurement data transfer time varies depending on measurement conditions and computers.

Host computer:	HP Z420 Workstation, Xeon CPU ES-1620 0 @3.60 GHz
Display:	OFF
Impedance range mode:	AUTO (The overload has not been generated.)
OPEN/SHORT/LOAD compensation:	OFF
Test signal voltage monitor:	OFF

Table 62. Measurement transfer time under the following conditions

Interface	Data transfer format	Using :FETC? command (one point measurement)		Using data buffer memory (list sweep measurement)			
		Comparator ON	Comparator OFF	10 points	51 points	128 points	201 points
GPIB	ASCII	2	2	4	13	28	43
	ASCII Long	2	2	5	15	34	53
	Binary	2	2	4	10	21	36
USB	ASCII	2	2	3	8	16	23
	ASCII Long	2	2	4	9	19	28
	Binary	2	2	3	5	9	13
LAN	ASCII	3	4	5	12	24	36
	ASCII Long	3	3	5	13	29	44
	Binary	3	3	5	9	18	26

Table 63. Measurement data transfer time [ms]

DC bias test signal current (1.5 V/2.0 V): Output current: Max. 20 mA

### Option 001 (Power and DC Bias enhance):

DC bias voltage: DC bias voltage applied to DUT is given as:

**Equation 18.**  $V_{dut} = V_b - 100 \times I_b$

$V_{dut}$ [V]	DC bias voltage
$V_b$ [V]	DC bias setting voltage
$I_b$ [A]	DC bias current

**DC bias current:** DC bias current applied to DUT is given as:

**Equation 19.**  $I_{dut} = V_b / (100 + R_{dc})$

$I_{dut}$  [A]          DC bias current  
 $V_b$  [V]          DC bias setting voltage  
 $R_{dc}$  [ $\Omega$ ]        DUT's DC resistance

**Maximum DC bias current**

Impedance range [ $\Omega$ ]	Bias current isolation	OFF	
		Test signal voltage $\leq 2 V_{rms}$	Test signal voltage $> 2 V_{rms}$
0.1	Auto range mode: 100 mA Hold range mode: its values for the range.	20 mA	100 mA
1		20 mA	100 mA
10		20 mA	100 mA
100		20 mA	100 mA
300		2 mA	100 mA
1 k		2 mA	20 mA
3 k		200 $\mu$ A	20 mA
10 k		200 $\mu$ A	2 mA
30 k		20 $\mu$ A	2 mA
100 k		20 $\mu$ A	200 $\mu$ A

Table 64. Maximum DC bias current when the normal measurement can be performed.

When DC bias is applied to the DUT, add the following value to the absolute accuracy  $A_b$ .

SHORT	MED, LONG
$0.05\% \times (100 \text{ mV}/V_s) \times (1 + \sqrt{(100/F_m)})$	$0.01\% \times (100 \text{ mV}/V_s) \times (1 + \sqrt{(100/F_m)})$

Table 65. Only when  $F_m < 10 \text{ kHz}$  and  $|V_{dc}| > 5 \text{ V}$

$F_m$  [Hz]          Test frequency  
 $V_s$  [V]          Test signal voltage

## Relative measurement accuracy with bias current isolation

When DC bias Isolation is set to ON, add the following value to the open offset  $Y_o$ .

**Equation 20.**  $Y_o\_DCI1 \times (1 + 1/(V_s)) \times (1 + \sqrt{(500/F_m)}) + Y_o\_DCI2$

$Z_m$  [ $\Omega$ ] Impedance of DUT  
 $F_m$  [Hz] Test frequency  
 $V_s$  [V] Test signal voltage  
 $Y_o\_DCI1,2$  [S] Calculate this by using Table 66 and 67  
 $I_{dc}$  [A] DC bias isolation current

DC bias current range	Measurement time mode	
	SHORT	MED, LONG
20 $\mu$ A	0 S	0 S
200 $\mu$ A	0.25 nS	0.05 nS
2 mA	2.5 nS	0.5 nS
20 mA	25 nS	5 nS
100 mA	250 nS	50 nS

Table 66.  $Y_o\_DCI1$  value

DC bias current range	Measurement time mode			
	$\leq 100 \Omega$	300 $\Omega$ , 1 k $\Omega$	3 k $\Omega$ , 10 k $\Omega$	30 k $\Omega$ , 100 k $\Omega$
20 $\mu$ A	0 S	0 S	0 S	0 S
200 $\mu$ A	0 S	0 S	0 S	0 S
2 mA	0 S	0 S	0 S	3 nS
20 mA	0 S	0 S	30 nS	30 nS
100 mA	0 S	300 nS	300 nS	300 nS

Table 67.  $Y_o\_DCI2$  value

## DC bias settling time

When DC bias is set to ON, add the following value to the settling time:

	Bias	Settling time
1	Standard	Capacitance of DUT × 100 × loge (2/1.8 m) + 3 m
2	Option 001	Capacitance of DUT × 100 × loge (40/1.8 m) + 3 m

Table 68. DC bias settling time

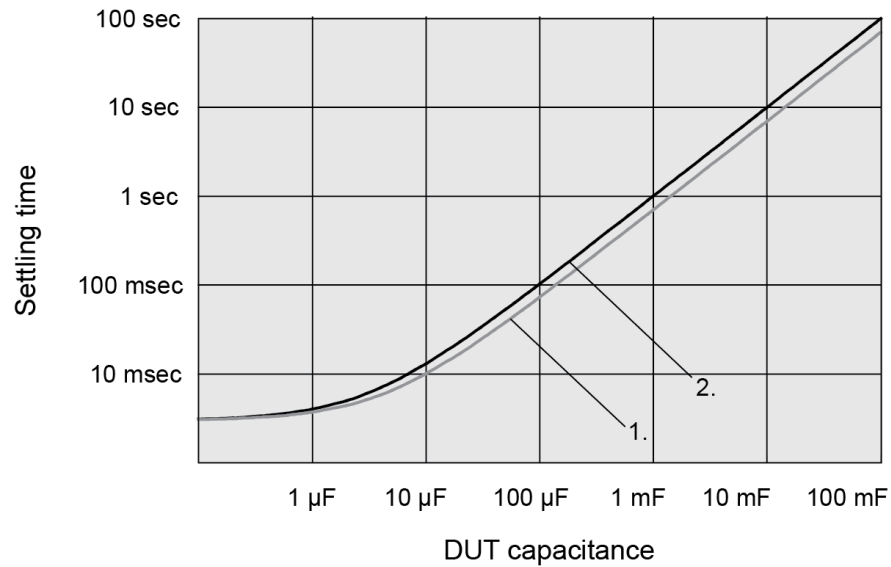

Figure 12. DC bias settling time

## Web Resources

Visit our Web sites for additional product information and literature.

E4980A Precision LCR Meter  
[www.keysight.com/find/e4980a](http://www.keysight.com/find/e4980a)

E4980AL Precision LCR Meter  
[www.keysight.com/find/e4980al](http://www.keysight.com/find/e4980al)

LCR Meters & Impedance Measurement Products  
[www.keysight.com/find/impedance](http://www.keysight.com/find/impedance)

RF & MW test accessories  
[www.keysight.com/find/mta](http://www.keysight.com/find/mta)

Learn more at: [www.keysight.com](http://www.keysight.com)

For more information on Keysight Technologies' products, applications or services, please contact your local Keysight office. The complete list is available at:  
[www.keysight.com/find/contactus](http://www.keysight.com/find/contactus)

