

**kHz Range Crystal unit**

- Package size (3.2 mm × 1.5 mm × 0.9 mm)
- Fundamental mode
- Reference weight Typ.13 mg

**[ 1 ] Product Number / Product Name / Marking**

(1-1) Product Number / Ordering Code

**X1A0001610001xx**

Last 2 digits code(xx) defines Quantity.

The standard is "16", 3 000 pcs/Reel.

(1-2) Product Name / Model Name

FC3215AN 32.768000 kHz 12.5 +20.0-20.0

**[ 2 ] Absolute maximum ratings**

Parameter	Symbol	Specifications			Unit	Conditions
		Min.	Typ.	Max.		
Storage temperature	T_stg	-55	-	+125	°C	Storage as single product
Maximum drive level	GL	-	-	0.5	μW	

**[ 3 ] Specifications(characteristics)**

Parameter	Symbol	Specifications			Unit	Conditions
		Min.	Typ.	Max.		
Nominal frequency	f_nom	—	32.768000	—	kHz	
Operating temperature	T_use	-40	-	+105	°C	
Level of drive	DL	-	0.1	0.5	μW	
Frequency tolerance	f_tol	-20	0	20	x 10 <sup>-6</sup>	+25 °C DL = 0.1 μW
Turnover temperature	Ti	+20	+25	+30	°C	
Parabolic coefficient	B	-	-	-0.04	x 10 <sup>-6</sup> /°C <sup>2</sup>	
Load capacitance	CL	-	12.5	-	pF	
Motional resistance (ESR)	R1	-	35	-	kΩ	+25 °C
		-	-	50		-40 °C to +85 °C
		-	-	60		-40 °C to +105 °C
Motional capacitance	C1	-	8.4	-	fF	
Shunt capacitance	C0	-	1.6	-	pF	
Motional inductance	L1	-	2.8	-	kH	
Frequency aging	f_age	-3	-	+3	x10 <sup>-6</sup> /yea	+25 °C, First year

**[ For other general specifications, please refer to the attached Full Data Sheet below ]**

# Low ESR 50 kΩ Max. 32.768 kHz Crystal Unit: FC3215AN

## Features

- Package size: 3.2 x 1.5 mm, t = 0.9 mm Max.
- Nominal frequency range: 32.768 kHz
- Frequency tolerance:  $\pm 20 \times 10^{-6}$  (+25 °C  $\pm 5$  °C)
- Operating temperature: -40 °C to +105 °C
- ESR: 35 kΩ Typ. (+25 °C)  
50 kΩ Max. (-40 °C to +85 °C)  
60 kΩ Max. (-40 °C to +105 °C)

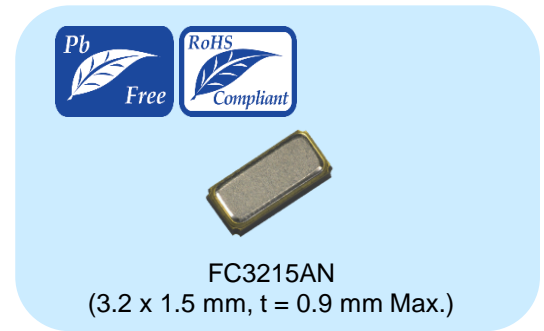

## Applications

- Wireless Modules for Sub-clock
- Wearable Products
- Low Power MCUs for Sub-clock
- Battery Powered IoT Products

## Description

FC3215AN is a low ESR and compact 32.768 kHz crystal unit that has a robust Pb-free metal lid + seam sealed package.

It is equipped with a newly redesigned crystal element based on our in-house design and production technology expertise of tuning-fork crystal devices over the decades. It is ideal for applications that require low current consumption, such battery powered IoT devices .

It also supports an operating temperature range of up to +105 °C.

## Outline Drawing and Terminal Assignment

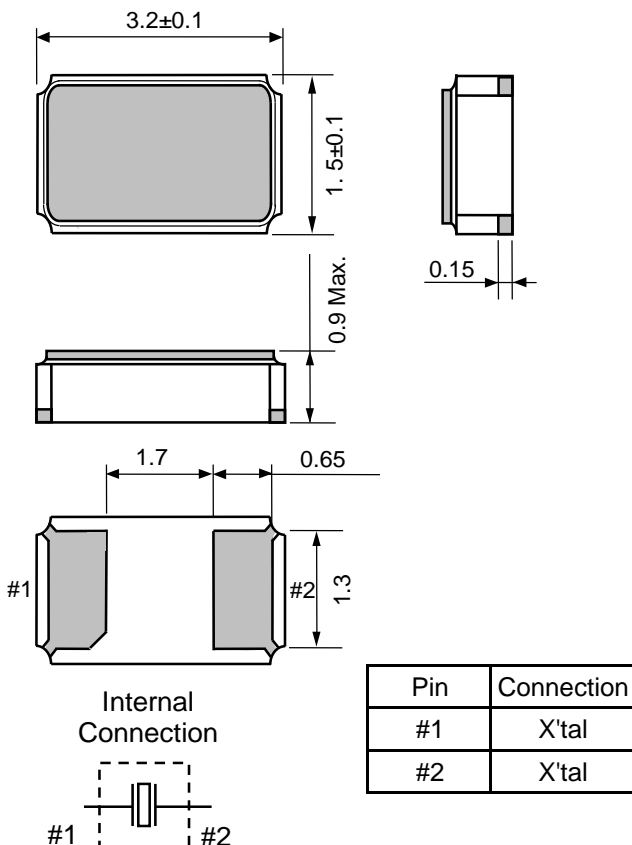

## Typical Performance

Low ESR

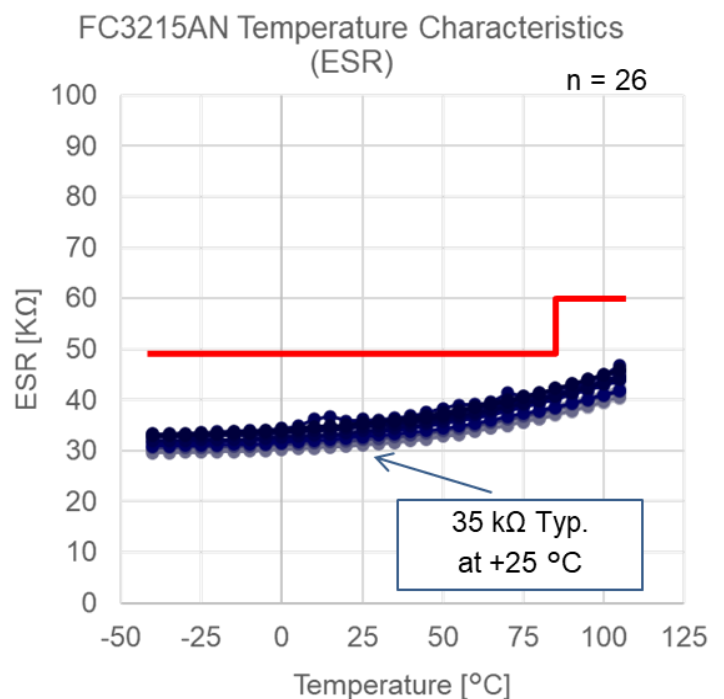

## [ 1 ] Product Number / Product Name

(1-1) Product Number

X1A000161xxxx16 (Please contact Epson for details)

(1-2) Product Name (Standard Form)

FC3215AN 32.768000kHz 12.5 +20.0-20.0

① ② ③ ④

①Model ②Frequency ③Load capacitance (pF) ④Frequency tolerance ( $\times 10^{-6}$ , +25 °C)

## [ 2 ] Absolute Maximum Ratings

Item	Symbol	Rating value			Unit	Note
		Min.	Typ.	Max.		
Storage temperature range	T_stg	-55	-	+125	°C	
Maximum level of drive	GL	-	-	0.5	$\mu$ W	

## [ 3 ] Operating Conditions

Item	Symbol	Rating value			Unit	Note
		Min.	Typ.	Max.		
Operating temperature range	T_use	-40	-	+105	°C	
Level of drive	DL	0.01	0.1	0.5	$\mu$ W	

## [ 4 ] Static Characteristics

Item	Symbol	Specifications	Unit	Condition / Remarks
Nominal frequency range	f_nom	32.768	kHz	
Frequency tolerance	f_tol	$\pm 20$	$\times 10^{-6}$	T_use = +25 °C $\pm$ 3 °C DL = 0.1 $\mu$ W This is not include frequency aging
Turnover temperature	Ti	+25 $\pm$ 5	°C	
Parabolic coefficient	B	-0.04 Max.	$\times 10^{-6} / ^\circ\text{C}^2$	
Motional resistance (ESR)	R1	35 Typ. (+25 °C)	k $\Omega$	Measuring instrument: Keysight 4294A DL = 0.5 $\mu$ W
		50 Max. (-40 °C to +85 °C)		
		60 Max. (-40 °C to +105 °C)		
Motional capacitance	C1	8.4 Typ.	fF	
Shunt capacitance	C0	1.6 Typ.	pF	
Load capacitance	CL	9, 12.5	pF	
Isolation resistance	IR	200 Min.	M $\Omega$	
Frequency aging	f_age	$\pm 3$	$\times 10^{-6}$	T_use = +25 °C, First year, DL = 0.1 $\mu$ W

## [ 5 ] Frequency and ESR vs. Temperature Characteristics

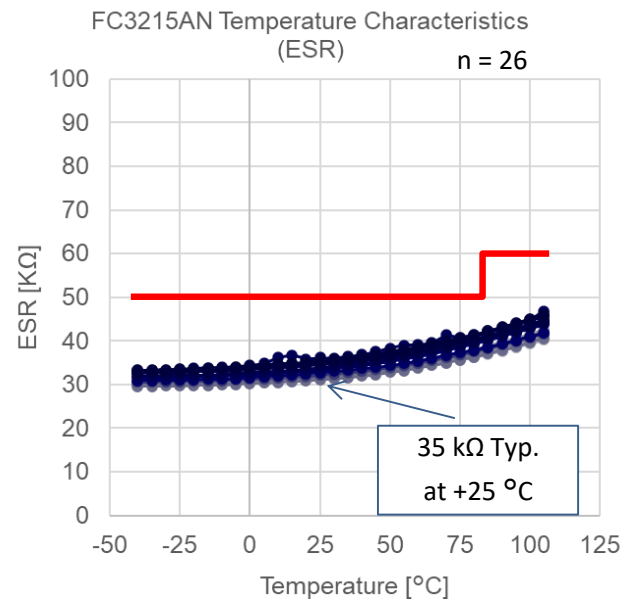
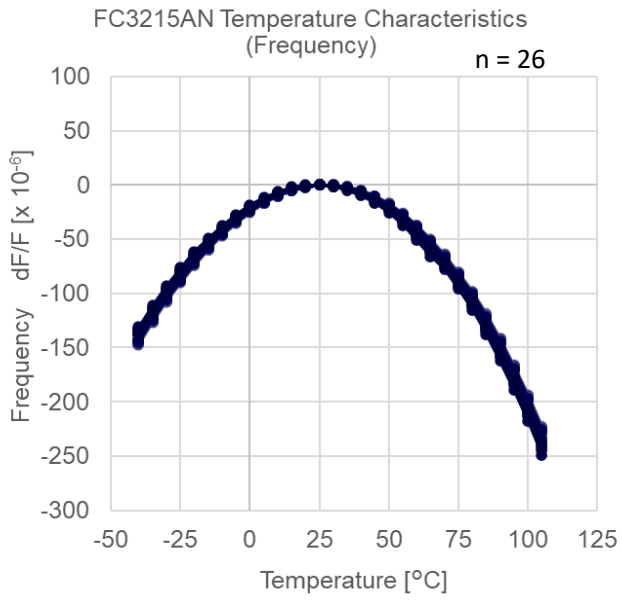

[ 6 ] Marking Description

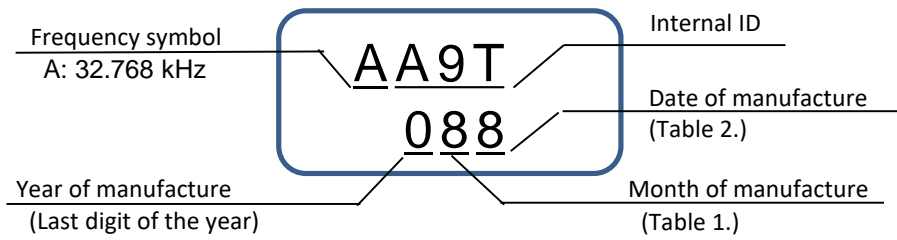

Table 1. Month of manufacture

Month	Jan	Feb	Mar	Apr	May	Jun	Jul	Aug	Sep	Oct	Nov	Dec
Code	1	2	3	4	5	6	7	8	9	X	Y	Z

Table 2. Date of manufacture

Date	1st	2nd	3rd	4th	5th	6th	7th	8th	9th	10th	11th	12th
Code	1	2	3	4	5	6	7	8	9	A	B	C
Date	13th	14th	15th	16th	17th	18th	19th	20th	21st	22nd	23rd	24th
Code	D	E	F	G	H	J	K	L	M	N	P	Q
Date	25th	26th	27th	28th	29th	30th	31st					
Code	R	S	T	U	V	W	X					

[ 7 ] Outline Drawing and Recommended Footprint

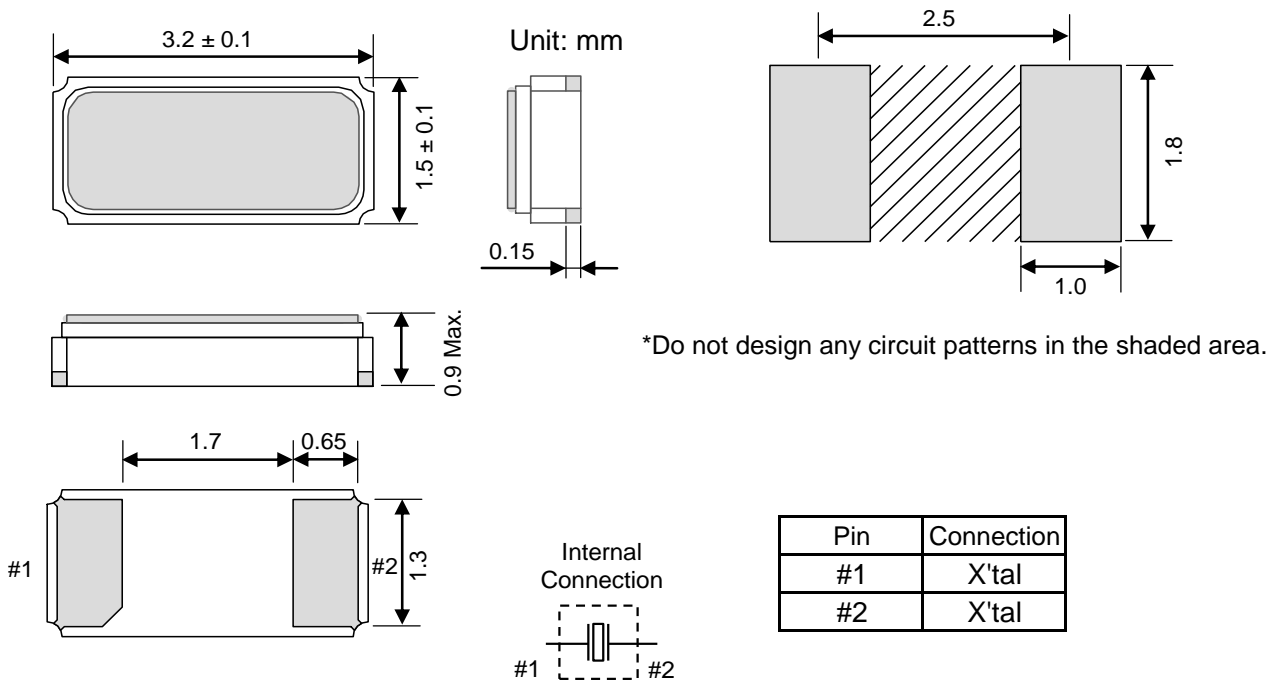

Reference weight Typ.: 13 mg

Terminal coating: Au plating

## [ 8 ] Moisture Sensitivity Level

Parameter	Specification	Conditions
MSL	LEVEL1	IPC/JEDEC J-STD-020D.01

## [ 9 ] Reflow Profile (IPC/JEDEC J-STD-020D.01)

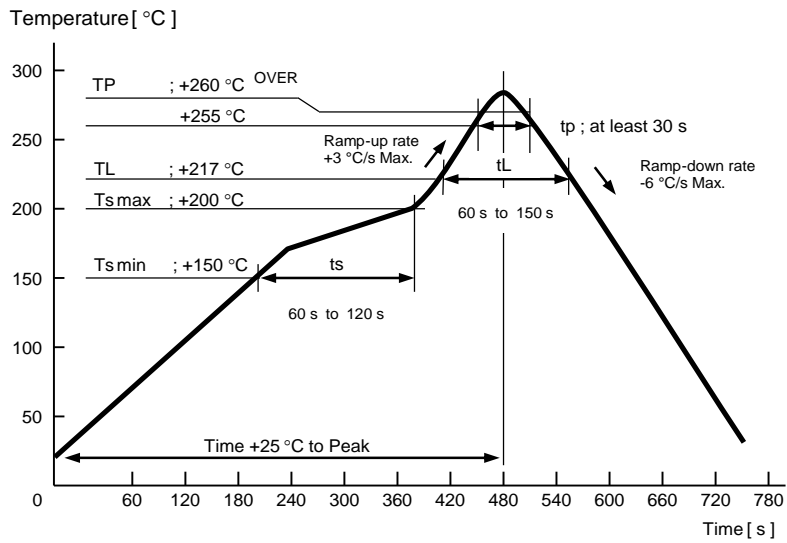

## [ 10 ] Packing Information

## (1) Packing Quantity

The last two digits of the Product Number (X1A000161xxxx16) are a code that defines the packing quantity  
The standard is "16" for a 3 000 pcs/Reel.

## (2) Taping Specification

Compliant to EIA-481, IEC 60286 and JIS C0806

## (2-1) Tape Dimensions

Carrier Tape Material : PS (Polystyrene)

Top Tape Material : PET (Polyethylene Terephthalate) +PE (Polyethylene)

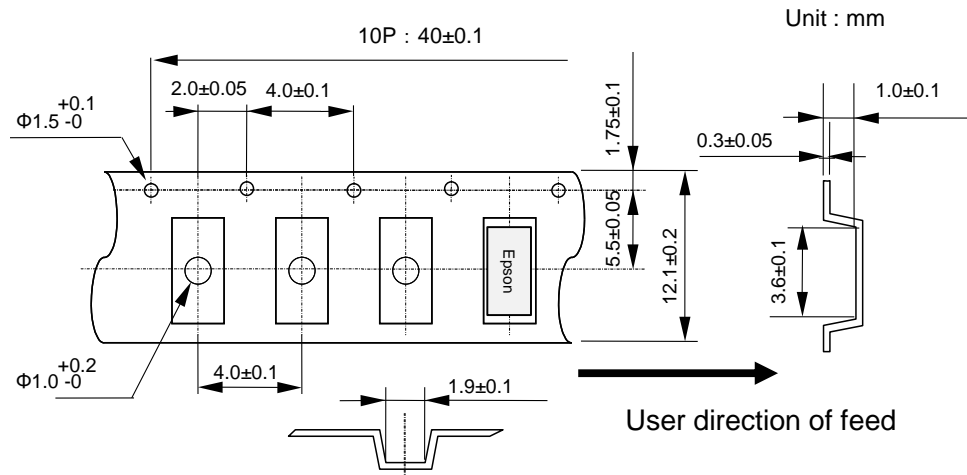

## (2-2) Reel Dimensions

Center Material : PS (Polystyrene)

Reel Material : PS (Polystyrene)

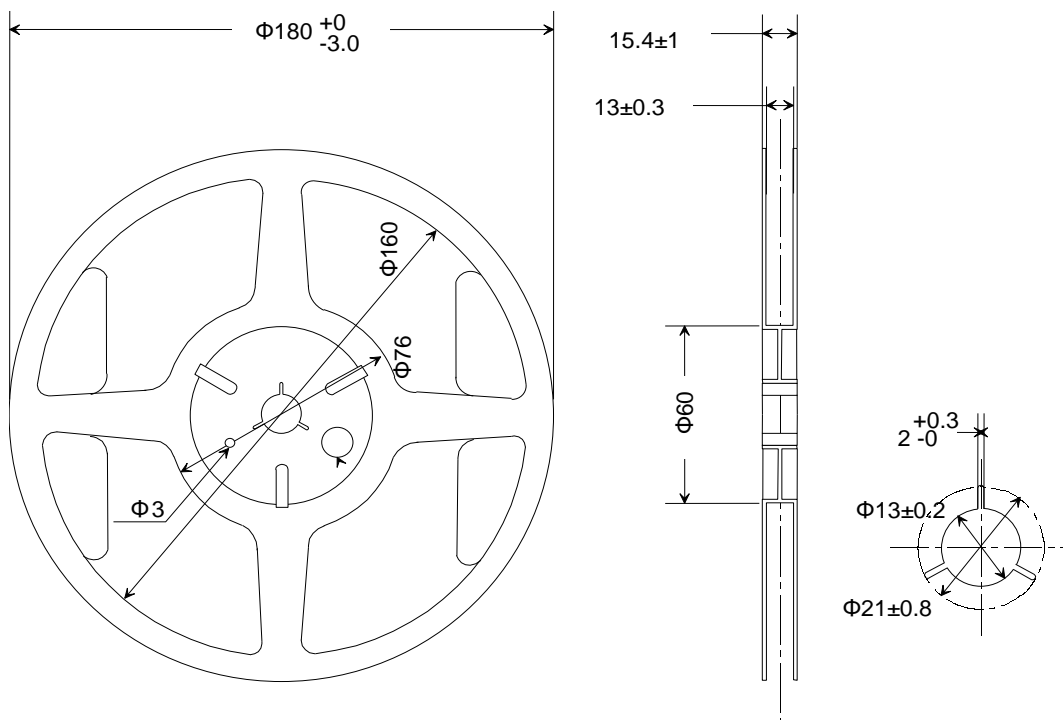

## [ 11 ] Handling Precautions

Prior to using this product, please carefully read the section entitled “Precautions” on our Web site (<https://www5.epsondevice.com/en/information/#precaution>) for instructions on how to handle and use the product properly to ensure optimal performance of the product in your system.

Before using the product under any conditions other than those specified therein, please consult with us to verify and confirm that the performance of the product will not be negatively affected by usage under such conditions.

In addition to the foregoing precautions, in order to avoid the deteriorating performance of the product, we strongly recommend that you DO NOT use the product under ANY of the following conditions:

1. This product should be reflowed no more than 3 times. If rework is needed after reflow, please correct it with a soldering iron with the tip set for a temperature of +350 °C or less and only contact each terminal once and for no more than 5 seconds. If this product is mounted on the bottom of the board during a reflow please check that it soldered down properly afterwards.
2. This product can be damaged by mechanical shock during the soldering process depending on the equipment used, process conditions, and any impact forces experienced. Always follow appropriate procedures, particularly when changing the assembly process in anyway and be sure to follow applicable process qualification standards before starting production.
3. Product failures during the warranty period only apply when the product is used according to the recommended operating conditions described in the specifications. Products that have been opened for analysis or damaged will not be covered. It is recommended to store and use in normal temperature and humidity environments described in the specifications to ensure frequency accuracy and prevent moisture condensation. If the product is stored for more than one year, please confirm the pin solderability prior to use.
4. Keep PCB routing from the output terminal(s) to the load as short as possible for best performance.
5. The use of ultrasonic technology for cleaning, bonding, etc. can damage the Xtal unit inside this product. Please carefully check for this consideration before using ultrasonic equipment for volume production with this product.
6. If the oscillation circuit is exposed to condensation, the frequency may change or oscillation may stop. Do not use in any conditions where condensation occurs.
7. If an excessive excitation is applied to the crystal unit, the characteristics may be degraded or destruction may occur. Design the oscillation circuit so that the excitation level is appropriate.
8. Depending on the method and conditions used to measure characteristic values such as frequency, deviation from our measured values may occur. Please check and verify the characteristics before use.
9. Do not route any signal lines, supply voltage lines, or GND lines underneath the area where the oscillators are mounted including any internal layers and on the opposite side of the PCB. To avoid any issues due to interference of other signal lines, please take care not to place signal lines near the product as this may have an adverse affect on the performance of the product.
10. If sufficient negative resistance is not provided by the oscillation circuit, the Xtal may not oscillate or take a long time to start. Please design the circuit as follows:

How to check the negative resistance.

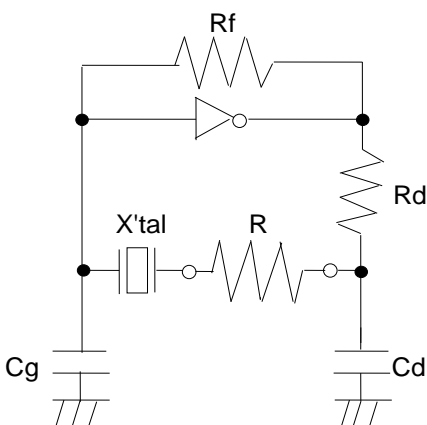

- (1) Connect the resistance (R) to the circuit in series with the crystal resonator.
- (2) Adjust (R) so that oscillation can start (or stop).
- (3) Measure (R) when oscillation just start (or stop) per instruction in (2) above.
- (4) Get the negative resistance  
 $-R = R + R1$  value.
- (5) Recommended  $-R$   
 $-R > R1 \times 5$



## PROMOTION OF ENVIRONMENTAL MANAGEMENT SYSTEM CONFORMING TO INTERNATIONAL STANDARDS

At Seiko Epson, all environmental initiatives operate under the Plan-Do-Check-Action (PDCA) cycle designed to achieve continuous improvements. The environmental management system (EMS) operates under the ISO 14001 environmental management standard.

All of our major manufacturing and non-manufacturing sites, in Japan and overseas, completed the acquisition of ISO 14001 certification.



ISO 14000 is an international standard for environmental management that was established by the International Standards Organization in 1996 against the background of growing concern regarding global warming, destruction of the ozone layer, and global deforestation.

## WORKING FOR HIGH QUALITY

In order to provide high quality and reliable products and services than meet customer needs, Seiko Epson made early efforts towards obtaining ISO9000 series certification and has acquired ISO9001 for all business establishments in Japan and abroad. We have also acquired IATF 16949 certification that is requested strongly by major manufacturers as standard.

IATF 16949 is the international standard that added the sector-specific supplemental requirements for automotive industry based on ISO9001.

### ■ Explanation of marks used in this datasheet

	<p>●Pb free.</p>
	<p>●Complies with EU RoHS directive. *About the products without the Pb-free mark. Contains Pb in products exempted by EU RoHS directive (Contains Pb in sealing glass, high melting temperature type solder or other)</p>

NOTICE: PLEASE READ CAREFULLY BELOW BEFORE THE USE OF THIS DOCUMENT ©Seiko Epson Corporation 2020

- The content of this document is subject to change without notice. Before purchasing or using Epson products, please contact with sales representative of Seiko Epson Corporation ("Epson") for the latest information and be always sure to check the latest information published on Epson's official web sites and resources.
- This document may not be copied, reproduced, or used for any other purposes, in whole or in part, without Epson's prior consent.
- Information provided in this document including, but not limited to application circuits, programs and usage, is for reference purpose only. Epson makes no guarantees against any infringements or damages to any third parties' intellectual property rights or any other rights resulting from the information. This document does not grant you any licenses, any intellectual property rights or any other rights with respect to Epson products owned by Epson or any third parties.
- Using Epson products, you shall be responsible for safe design in your products; that is, your hardware, software, and/or systems shall be designed enough to prevent any critical harm or damages to life, health or property, even if any malfunction or failure might be caused by Epson products. In designing your products with Epson products, please be sure to check and comply with the latest information regarding Epson products (including, but not limited to this document, specifications, data sheets, manuals, and Epson's web site). Using technical contents such as product data, graphic and chart, and technical information, including programs, algorithms and application circuit examples under this document, you shall evaluate your products thoroughly both in stand-alone basis and within your overall systems. You shall be solely responsible for deciding whether to adopt/use Epson products with your products.
- Epson has prepared this document carefully to be accurate and dependable, but Epson does not guarantee that the information is always accurate and complete. Epson assumes no responsibility for any damages you incurred due to any misinformation in this document.
- No dismantling, analysis, reverse engineering, modification, alteration, adaptation, reproduction, etc., of Epson products is allowed.
- Epson products have been designed, developed and manufactured to be used in general electronic applications and specifically requires particular quality or extremely high reliability in order to refrain from causing any malfunction or failure leading to critical harm to life and health, serious property damage, or severe impact on society, including, but not limited to listed below ("Specific Purpose"). Therefore, you are strongly advised to use Epson products only for the Anticipated Purpose. Should you desire to purchase and use Epson products for Specific Purpose, Epson makes no warranty and disclaims with respect to Epson products, whether express or implied, including without limitation any implied warranty of merchantability or fitness for any Specific Purpose. Please be sure to contact our sales representative in advance, if you desire Epson products for Specific Purpose:  
Space equipment (artificial satellites, rockets, etc.) / Transportation vehicles and their control equipment (automobiles, aircraft, trains, ships, etc.) / Medical equipment / Relay equipment to be placed on sea floor / Power station control equipment / Disaster or crime prevention equipment / Traffic control equipment / Financial equipment  
Other applications requiring similar levels of reliability as the above
- Epson products listed in this document and our associated technologies shall not be used in any equipment or systems that laws and regulations in Japan or any other countries prohibit to manufacture, use or sell. Furthermore, Epson products and our associated technologies shall not be used for the purposes of military weapons development (e.g. mass destruction weapons), military use, or any other military applications. If exporting Epson products or our associated technologies, please be sure to comply with the Foreign Exchange and Foreign Trade Control Act in Japan, Export Administration Regulations in the U.S.A (EAR) and other export-related laws and regulations in Japan and any other countries and to follow their required procedures.
- Epson assumes no responsibility for any damages (whether direct or indirect) caused by or in relation with your non-compliance with the terms and conditions in this document or for any damages (whether direct or indirect) incurred by any third party that you give, transfer or assign Epson products.
- For more details or other concerns about this document, please contact our sales representative.
- Company names and product names listed in this document are trademarks or registered trademarks of their respective companies.