

## 3-phase inverter based on STSPIN32F0251

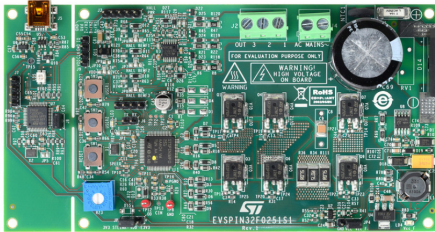

### Features

- Input voltage from 20 V to 120 V DC/AC
- STD17NF25 MOSFETs power stage featuring:
  - $V_{DS} = 250 \text{ V}$
  - $R_{DS(on)} \text{ max.} = 0.165 \Omega$
- Overcurrent threshold set to  $16 A_{peak}$
- Dual footprint for IGBT/MOSFET package:
  - DPAK
  - PowerFlat 6x5
- Single-shunt current sensing, suitable for:
  - Sensored or sensorless 6 steps algorithm
  - Single-shunt vector (FOC) algorithm
- Smart shutdown overcurrent protection
- Digital Hall sensors and encoder input
- Bus voltage sensing
- 15 V VCC and 3.3 V VDD supplies
- Embedded ST-LINK/V2-1
- Easy user interface with buttons and trimmer
- RoHS compliant

Product status link

[EVSPIN32F0251S1](#)

### Application

- Battery operated and 110 Vac supplied power and garden tools
- Industrial fans and pumps
- Home appliances
- Industrial and home automation

### Description

The **EVSPIN32F0251S1** board is a 3-phase complete inverter based on the STSPIN32F0251 controller, which embeds a 3-phase 250 V gate driver and a Cortex®-M0 STM32 MCU. The power stage features STD17NF25 MOSFETs, but can be populated with any IGBT or Power MOSFET in DPAK or powerFLAT 6x5 package.

The board has a single-shunt sensing topology, and both the field-oriented control (FOC) and sensored or sensorless 6-step control can be implemented. This allows driving permanent magnet synchronous motors (PMSMs) and brushless DC (BLDC) motors.

The evaluation board is compatible with a wide range input voltage from 20 V to 120 V DC/AC, and includes a power supply stage with the VIPER013BLS in buck configuration to generate +15 V and +3.3 V supply voltage required by the application.

Debug and configuration of FW can be performed with standard STM32 tools through the detachable STLINK-debugger. SWD and UART TX-RX connectors are also available.

## 1 Safety and operating instructions



### 1.1 General terms

**Warning:**

During assembly, testing, and operation, the evaluation board poses several inherent hazards, including bare wires, moving or rotating parts and hot surfaces.

**Danger:**

*There is danger of serious personal injury, property damage or death due to electrical shock and burn hazards if the kit or components are improperly used or installed incorrectly.*

The kit is not electrically isolated from the high-voltage supply AC/DC input. The evaluation board is directly linked to the mains voltage. No insulation is ensured between the accessible parts and the high voltage. All measuring equipment must be isolated from the mains before powering the board. When using an oscilloscope with the demo, it must be isolated from the AC line. This prevents shock from occurring as a result of touching any single point in the circuit, but does NOT prevent shock when touching two or more points in the circuit.

All operations involving transportation, installation and use, and maintenance must be performed by skilled technical personnel able to understand and implement national accident prevention regulations. For the purposes of these basic safety instructions, "skilled technical personnel" are suitably qualified people who are familiar with the installation, use and maintenance of power electronic systems.

### 1.2 Intended use of evaluation board

The evaluation board is designed for demonstration purposes only, and must not be used for electrical installations or machinery. Technical data and information concerning the power supply conditions are detailed in the documentation and should be strictly observed.

### 1.3 Installing the evaluation board

- The installation and cooling of the evaluation board must be in accordance with the specifications and target application.
- The motor drive converters must be protected against excessive strain. In particular, components should not be bent or isolating distances altered during transportation or handling.
- No contact must be made with other electronic components and contacts.
- The board contains electrostatically-sensitive components that are prone to damage if used incorrectly. Do not mechanically damage or destroy the electrical components (potential health risks).

### 1.4 Operating the evaluation board

To operate properly the board, follow these safety rules.

1. Work Area Safety:

- The work area must be clean and tidy.
- Do not work alone when boards are energized.
- Protect against inadvertent access to the area where the board is energized using suitable barriers and signs.
- A system architecture that supplies power to the evaluation board must be equipped with additional control and protective devices in accordance with the applicable safety requirements (i.e., compliance with technical equipment and accident prevention rules).
- Use non-conductive and stable work surface.
- Use adequately insulated clamps and wires to attach measurement probes and instruments.

## 2. Electrical Safety:

- Remove power supply from the board and electrical loads before performing any electrical measurement.
- Proceed with the arrangement of measurement setup, wiring or configuration paying attention to high voltage sections.
- Once the setup is complete, energize the board.

---

### **Danger:**

*Do not touch the evaluation board when it is energized or immediately after it has been disconnected from the voltage supply as several parts and power terminals containing potentially energized capacitors need time to discharge.*

*Do not touch the boards after disconnection from the voltage supply as several parts like heat sinks and transformers may still be very hot.*

*The kit is not electrically isolated from the AC/DC input. The USB interface of the board does not insulate host computer from high voltage. When the board is supplied at a voltage outside the ELV range, a proper insulation method such as a USB isolator must be used to operate the board.*

---

## 3. Personal Safety

- Always wear suitable personal protective equipment such as, for example, insulating gloves and safety glasses.
- Take adequate precautions and install the board in such a way to prevent accidental touch. Use protective shields such as, for example, insulating box with interlocks if necessary.

## 2 Schematic diagram

Figure 1. EVSPIN32F0251S1 schematic – Driver output stage

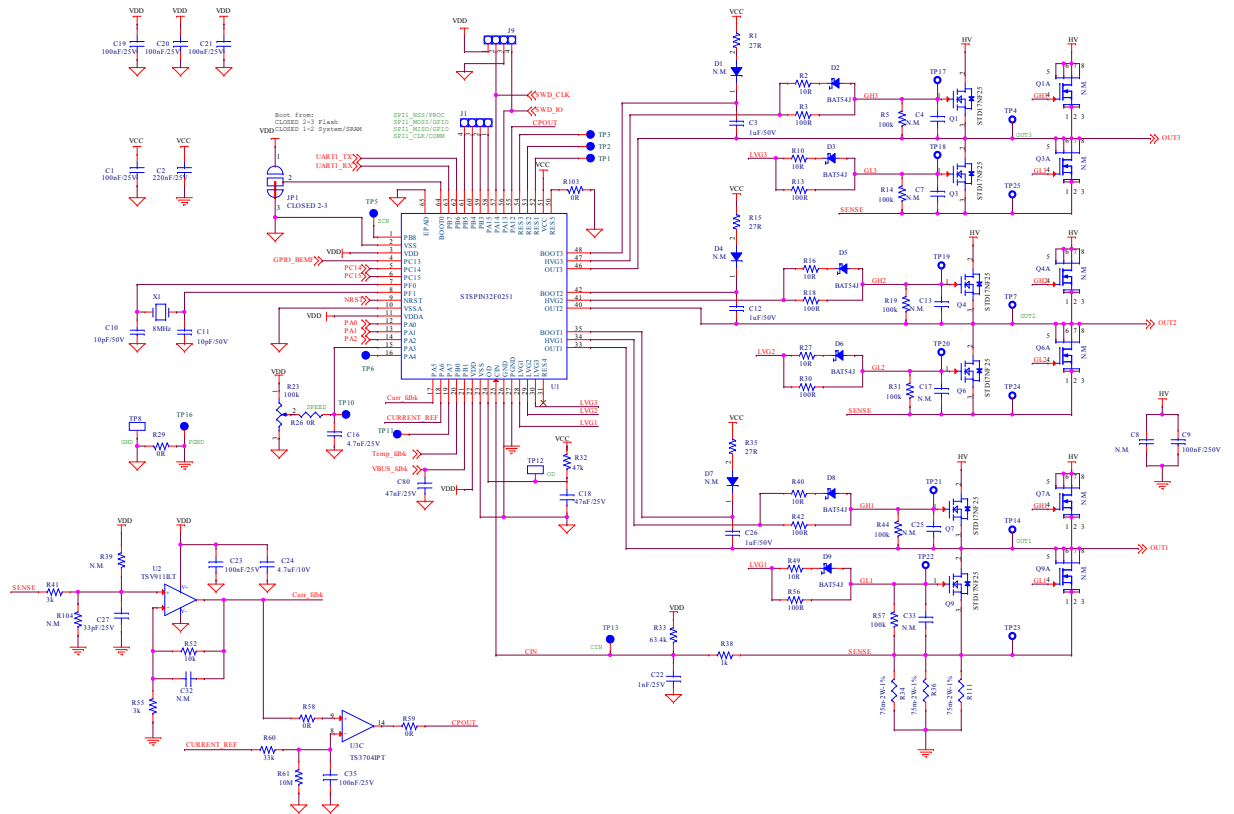
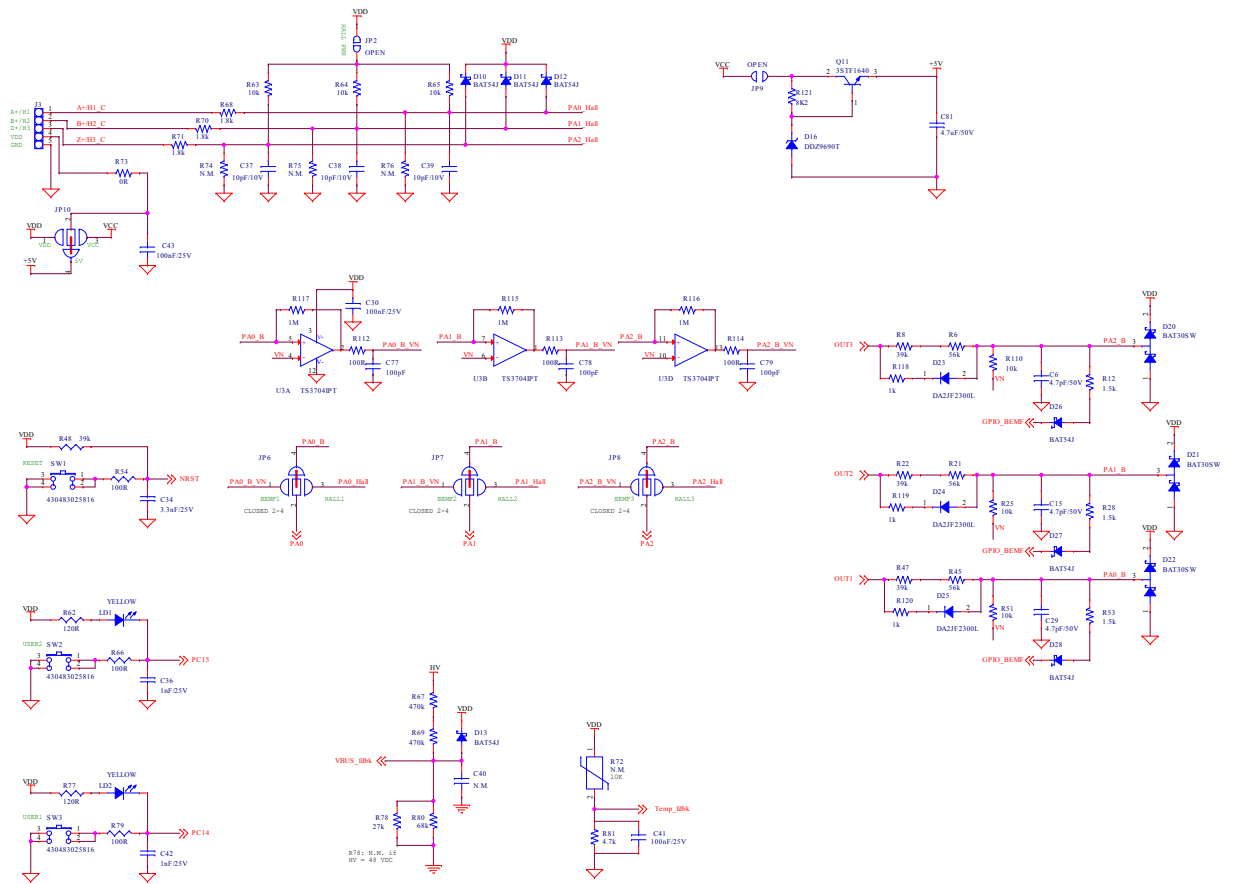

Figure 2. EVSPIN32F0251S1 schematic – Feedback network





### 3 Bill of material

**Table 1. Bill of Materials – Components common to all device variants**

Reference	Part Value	Description	Package	Manufacturer	Part Number
C1, C19, C20, C21, C23, C30, C35, C41, C43, C47, C53, C55, C56, C62, C63, C64, C65	100nF/25V	SMT ceramic capacitor	Size 0603	Wurth Elektronik	885012206071
C2,C72	220nF/25V	SMT ceramic capacitor	Size 0603	Wurth Elektronik	885012206073
C3, C12, C26, C70	1uF/50V	SMT ceramic capacitor	Size 0805	Wurth Elektronik	885012207103
C4,C7,C13, C17, C25, C32, C33, C40, C74	N.M.	SMT ceramic capacitor	Size 0603		
C6, C15, C29	4.7pF/50V	SMT ceramic capacitor	Size 0603	Wurth Elektronik	885012006049
C8	N.M.	Film capacitor	4x13 mm, Pitch 10 mm	Wurth Elektronik	890334023006
C9	100nF/250V	SMT ceramic capacitor	Size 1210	TDK	CGA6M3X7R2E104M2 00AE
C10,C11, C59, C60	10pF/50V	SMT ceramic capacitor	Size 0603	Wurth Elektronik	885012006051
C16	4.7nF/25V	SMT ceramic capacitor	Size 0603	Wurth Elektronik	885012206063
C18,C80	47nF/25V	SMT ceramic capacitor	Size 0603	Wurth Elektronik	885012206069
C22,C36, C42	1nF/25V	SMT ceramic capacitor	Size 0603	Wurth Elektronik	885012206059
C24	4.7uF/10V	SMT ceramic capacitor	Size 0805	Wurth Elektronik	885012207025
C27	33pF/25V	SMT ceramic capacitor	Size 0603	Wurth Elektronik	885012006035
C34	3.3nF/25V	SMT ceramic capacitor	Size 0603	Wurth Elektronik	885012206062
C37,C38, C39	10pF/10V	SMT ceramic capacitor	Size 0603	Wurth Elektronik	885012006002
C45	22uF/25V	SMT aluminum elect. capacitor	5x5.4 mm	Wurth Elektronik	865090442004
C48	10uF/10V	SMT ceramic capacitor	Size 1206	Wurth Elektronik	885012208018
C54,C58	1uF/10V	SMT ceramic capacitor	Size 0603	Wurth Elektronik	885012206026
C57	10nF/25V	SMT ceramic capacitor	Size 0603	Wurth Elektronik	885012206065
C61	100nF/50V	SMT ceramic capacitor	Size 0603	Wurth Elektronik	885012206095
C69A	N.M.	THT electrolytic capacitor	Radial p7.5 d18h25	Rubycon	450BXW68MEFC18X2 5
C69	270uF/250V	THT electrolytic capacitor	Radial p10 d22h27	Nichicon	LGN2E271MELZ25
C71	100nF/50V	SMT ceramic capacitor	Size 0805	Wurth Elektronik	885012207098
C73	1nF/10V	SMT ceramic capacitor	Size 0603	Wurth Elektronik	885012206008
C75	47uF/20V	Low ESR series of robust MnO2 solid electrolyte capacitors	D / E	AVX	TPS Series or equivalent
C76	1nF/50V	SMT ceramic capacitor	Size 0603	Wurth Elektronik	885012206083
C77,C78, C79	100pF	SMT ceramic capacitor	Size 0603		



Reference	Part Value	Description	Package	Manufacturer	Part Number
C81	4.7uF/50V	SMT ceramic capacitor	Size 1206	Wurth Elektronik	885012208094
D1,D4,D7	N.M.	Turbo 2 ultrafast high-voltage rectifier	SMA	STMicroelectronics	STTH1L06A
D2,D3,D5, D6, D8, D9, D10, D11, D12, D13, D26, D27, D28	BAT54J	40V, 300mA small signal Schottky SMT Diode	SOD-323	STMicroelectronics	BAT54JFILM
D14	GBU802	8A glass passivated bridge rectifiers	GBU	Diodes Incorporated or Taiwan Semiconductor	GBU802 or GBU803
D15	3V3 N.M.	Zener	SOD-123		
D16	DDZ9690T	Surface mount Zener diode	SOD523	Diodes Incorporated	DDZ9690T-7
D17,D18	STTH1R04	Ultrafast recovery diode, 1A 400 V	SMA	STMicroelectronics	STTH1R04A
D19	BAT41Z	100V, 200mA Low capacitance small signal Schottky diode	SOD-123	STMicroelectronics	BAT41ZFILM
D20,D21, D22	BAT30SW	Small signal Schottky diodes	SOT-323	STMicroelectronics	BAT30SWFILM
D23,D24, D25	DA2JF2300L	300V fast recovery diode	SC-90A (SMini2-F5-B)	Panasonic	DA2JF2300L
F1A	N.M.	Time-lag radial lead micro fuse, 250Vac	RST-Bel Fuse	Bel Fuse	0697-xx
F1	10A/277 V slow	Surface mount fuse, time-lag T, 250Vac125Vdc	UMT250-Shurter	Schurter	3403.0176.24
JP1	Closed 2-3	SMT jumper	Soldering pad		
JP2	Open	SMT jumper	Soldering pad		
JP3,JP4	Closed 1-2	Strip connector 3 pos, 2.54mm	1x3 pins	Wurth Elektronik	61300311121
JP5	Open	SMT jumper	Soldering pad		
JP6,JP7, JP8	Closed 2-4	Jumper to solder	Soldering pads		
JP9	Open	SMT jumper			
JP10	Closed 2-4	Jumper to solder	Soldering pads		
J1,J7,J9	STRIP 1x4	Strip connector 4 pos, 2.54mm	1x4 pins	Wurth Elektronik	61300411121
J2	MORSV-508-3P_screw	Connector terminal block T.H. 3 positions 5.08mm	3 poles, pitch 5.08	Wurth Elektronik	691213510003
J3	STRIP 1x5	Strip connector 5 pos, 2.54mm	1x5 pins	Wurth Elektronik	61300511121
J4	MORSV-508-2P_screw	Connector terminal block T.H. 2 positions 5.08mm	2 poles, pitch 5.08	Wurth Elektronik	691213510002
J5	6510051612 1	Mini USB 2.0 type B SMD	Mini USB B	Wurth Elektronik	65100516121

Reference	Part Value	Description	Package	Manufacturer	Part Number
J6	STRIP 1x2	Strip connector 2 pos, 2.54mm	1x2 pins	Wurth Elektronik	61300211121
J8	Closed	Strip connector 2 pos, 2.54mm	1x2 pins	Wurth Elektronik	61300211121
LD1,LD2	Yellow	Yellow LED	Size 0603	Wurth Elektronik	150060YS75000
LD3	Red	Red LED	Size 0603	Wurth Elektronik	150060RS75000
LD5	Red-green	LED indicators, PLCC-4 red/ yellow green	PLCC 4	Avago	HSMF-A201-A00J1
LD4	Green	Green LED	Size 0805	Wurth Elektronik	150080GS75000
L1	330uH	SMD Power inductors for Automotive/Industrial applications		TAIYO YUDEN	EST1060T331MDGA
NTC1	5R	NTC thermistors for inrush current limiting	Pitch 5.08 mm	TDK	B57235S0509M000
Q1,Q3,Q4, Q6, Q7, Q9	STD17NF25	N-channel 250V, 0.140 O typ., 17A STRipFET™ II Power MOSFETs	DPAK	STMicroelectronics	STD17NF25
Q1A,Q3A, Q4A, Q6A, Q7A, Q9A	N.M.	N-channel Power MOSFET	PowerFLAT 6x5	STMicroelectronics	
Q10	BC847	General purpose_45V_100mA_225m W	SOT23	ON SEMICONDUCTO R	BC847BL
Q11	3STF1640	Low voltage high performance NPN power transistor	SOT-89	STMicroelectronics	3STF1640
RV1	N.M.	Varistor	Pitch 2.3x7.5 mm		
R1,R15,R35	27R	SMT resistor	Size 0805		
R2,R10, R16, R27, R40, R49	10R	SMT resistor	Size 0805		
R3,R13, R18, R30, R42, R56	100R	SMT resistor	Size 0805		
R5,R14,R19, R31, R44, R57, R99, R100, R106	100k	SMT resistor	Size 0603		
R6,R21, R45	56k	SMT resistor	Size 1206		
R8,R22,R47	39k	SMT resistor	Size 1206		
R12,R28, R53, R68, R70, R71	1.8k	SMT resistor	Size 0603		
R23	100k	Square trimpot trimming potentiometer	3386P	BOURNS	3386P-1-104-LF
R25,R51, R52, R63, R64, R65, R84, R97, R110	10k	SMT resistor	Size 0603		
R26,R29, R58, R59, R73, R89, R91, R93, R95	0R	SMT resistor	Size 0603		
R32	47k	SMT resistor	Size 0603		
R33	63.4k	SMT resistor	Size 0603		

Reference	Part Value	Description	Package	Manufacturer	Part Number
R34,R36, R111	75m-2W-1%	SMT resistor	Size 2512		
R38,R118, R119, R120	1k	SMT resistor	Size 0603		
R39,R74, R75, R76, R98, R104	N.M.	SMT resistor	Size 0603		
R41,R55	3k	SMT resistor	Size 0603		
R48	39k	SMT resistor	Size 0603		
R54,R66, R79, R85, R96, R101, R102, R112, R113, R114	100R	SMT resistor	Size 0603		
R60	33k	SMT resistor	Size 0603		
R61	10M	SMT resistor	Size 0603		
R62,R77	120R	SMT resistor	Size 0603		
R67,R69	470k	SMT resistor	Size 1206		
R72	N.M.	NTC resistor	Size 0805		
R81,R88, R92, R94	4.7k	SMT resistor	Size 0603		
R78	27k	SMT resistor	Size 0805		
R80	68k	SMT resistor	Size 0805		
R82	330R	SMT resistor	Size 0603		
R83	1.5k	SMT resistor	Size 1206		
R86	1.5k	SMT resistor	Size 0603		
R87	36k	SMT resistor	Size 0603		
R90,R109	2.7k	SMT resistor	Size 0603		
R103	0R	SMT resistor	Size 0603		
R105	15k	SMT resistor	Size 0603		
R107	8.66k	SMT resistor	Size 0603		
R108	0R	SMT resistor	Size 0805		
R115,R116, R117	1M	SMT resistor	Size 0603		
R121	8K2	SMT resistor	Size 0603		
SW1,SW2, SW3	4304830258 16	Tactile switches - 6x6 J-bend SMT		Würth Elektronik	430483025816
TP1	TPHIN1	Test point - PCB 1mm diameter	Copper pad		
TP2	TPHIN2	Test point - PCB 1mm diameter	Copper pad		
TP3	TPHIN3	Test point - PCB 1mm diameter	Copper pad		
TP4,TP7, TP14, TP17, TP18, TP19, TP20, TP21, TP22, TP23, TP24, TP25	N.M.	TP for probe	Diam. 1.27, Hole 0.8mm		

Reference	Part Value	Description	Package	Manufacturer	Part Number
TP5	PB8	Test point - PCB 1mm diameter	Copper pad		
TP6	PA4	Test point - PCB 1mm diameter	Copper pad		
TP8,TP12	TPTH-ANELLO-1mm	THT ring test point		Keystone	5003
TP10	PA3	Test point - PCB 1mm diameter	Copper pad		
TP11	PA7	Test point - PCB 1mm diameter	Copper pad		
TP13	GPIO_ZCR	Test point - PCB 1mm diameter	Copper pad		
TP15	NEEDLE-PAD-1.7mm	Test point - PCB 1.7mm diameter	Copper pad		
TP16	PGND	Test point - PCB 1mm diameter	Copper Pad		
U1	STSPIN32F0251	250V 3-phase controller with ARM Cortex MCU	TQFP64-10x10x1.0	STMicroelectronics	STSPIN32F0251/TR
U2	TSV911ILT	Single rail-to-rail input/output 8MHz operational amplifiers	SOT23-5	STMicroelectronics	TSV911ILT
U3	TS3704IPT	Micropower quad CMOS voltage comparators	TSSOP14	STMicroelectronics	TS3704IPT
U4	LD1117S33CTR	800mA, 3.3V adjustable and fixed low drop positive voltage regulator	SOT-223	STMicroelectronics	LD1117S33CTR
U5	USBLC6-2SC6	Very low capacitance ESD protection	SOT23-6L	STMicroelectronics	USBLC6-2SC6 / Y
U6	LD3985M33R	Ultra low drop and low noise BiCMOS Voltage Regulators	SOT23-5L	STMicroelectronics	LD3985M33R
U7	STM32F103CBT6	Medium-density performance line ARM®-based 32-bit MCU with 128 KB Flash, USB, CAN, 7 timers, 2 ADCs, 9 com. interfaces	LQFP48 - 7x7 mm	STMicroelectronics	STM32F103CBT6
U8	VIPer013	Energy saving off-line high voltage converter	SSOP10	STMicroelectronics	VIPer013BLS/TR
X1,X2	8MHz	Crystal 8.0000MHZ 8PF SMD	2.5x3.2 mm	NDK	NX3225GD-8MHZ-STD-CRA-3
		Rubber feet		Hammond	1421T6CL
J8,JP3,JP4		Female jumper isolated, pitch 2.54mm		Assmann WSW	AKSCT/Z BLACK
		P.C.B. EVSPIN32F0251S1 Rev.1.0		STMicroelectronics	

## 4 Layout and component placements

Figure 5. EVSPIN32F0251S1 – Board functions description

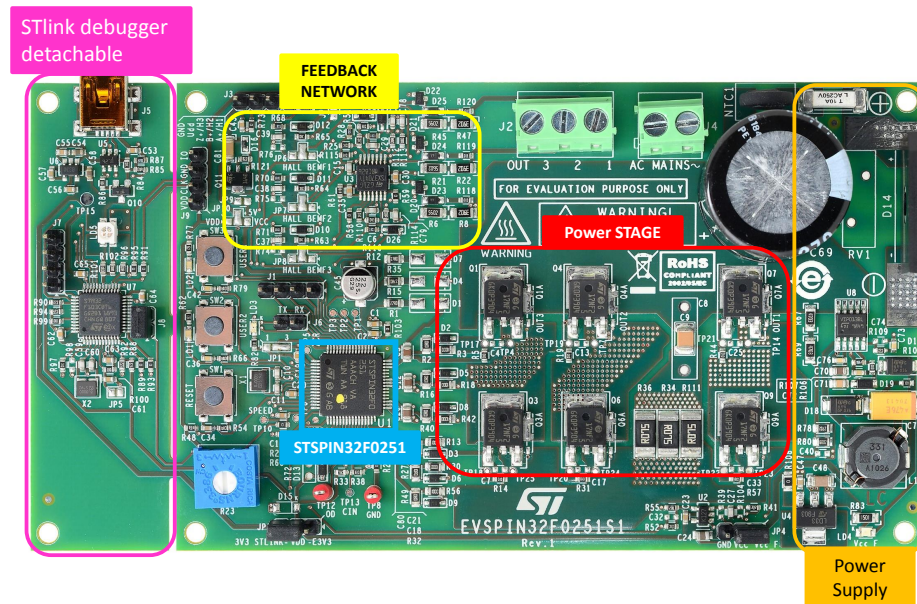

**Warning:**

The kit is not electrically isolated from the AC/DC input. The USB interface of the board does not insulate host computer from high voltage. When the board is supplied at a voltage outside the ELV range, a proper insulation method such as a USB isolator must be used to operate the board.

Figure 6. EVSPIN32F0251s – Layout (component placement top view)

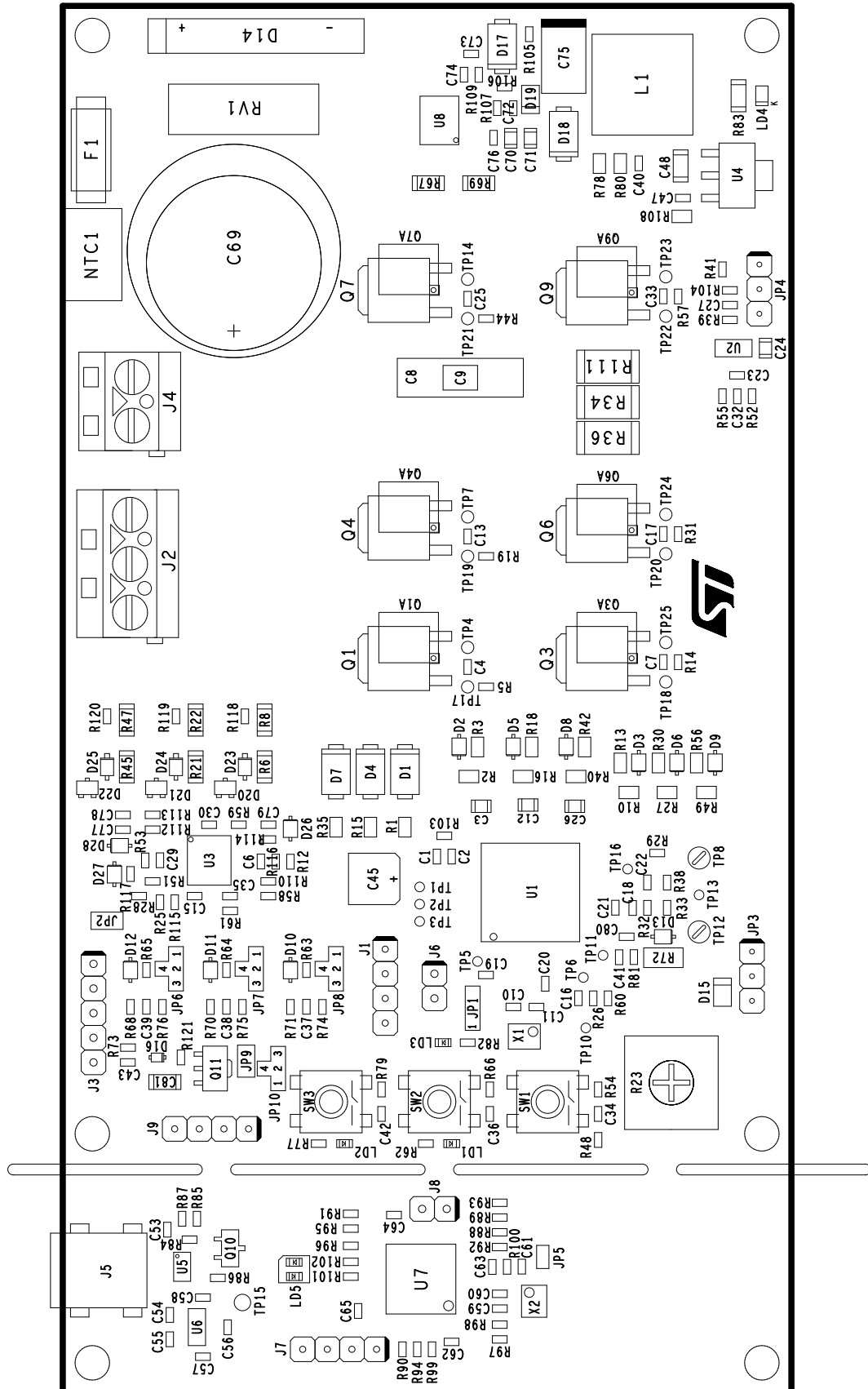

Figure 7. EVSPIN32F0251s – Layout (top layer)

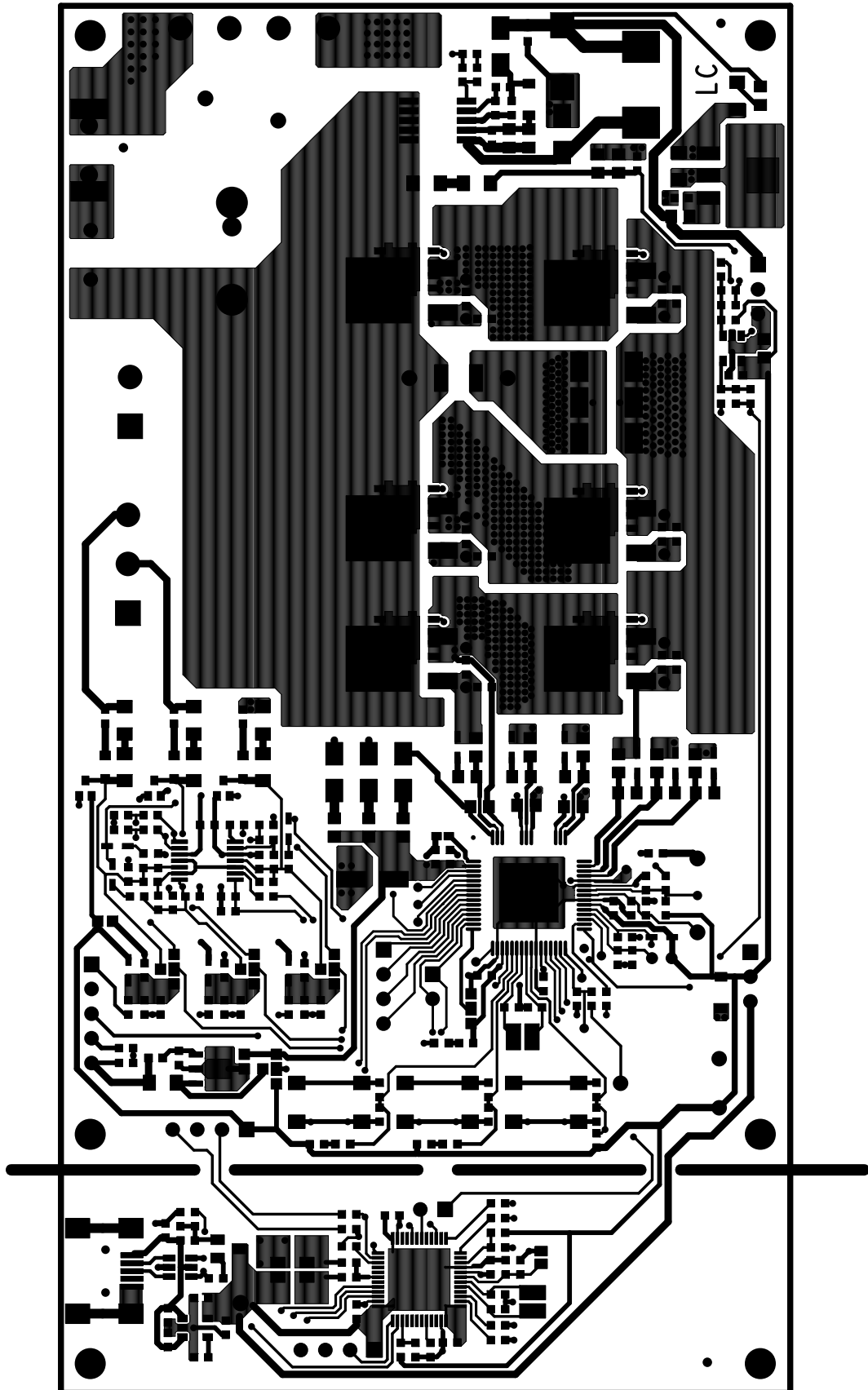
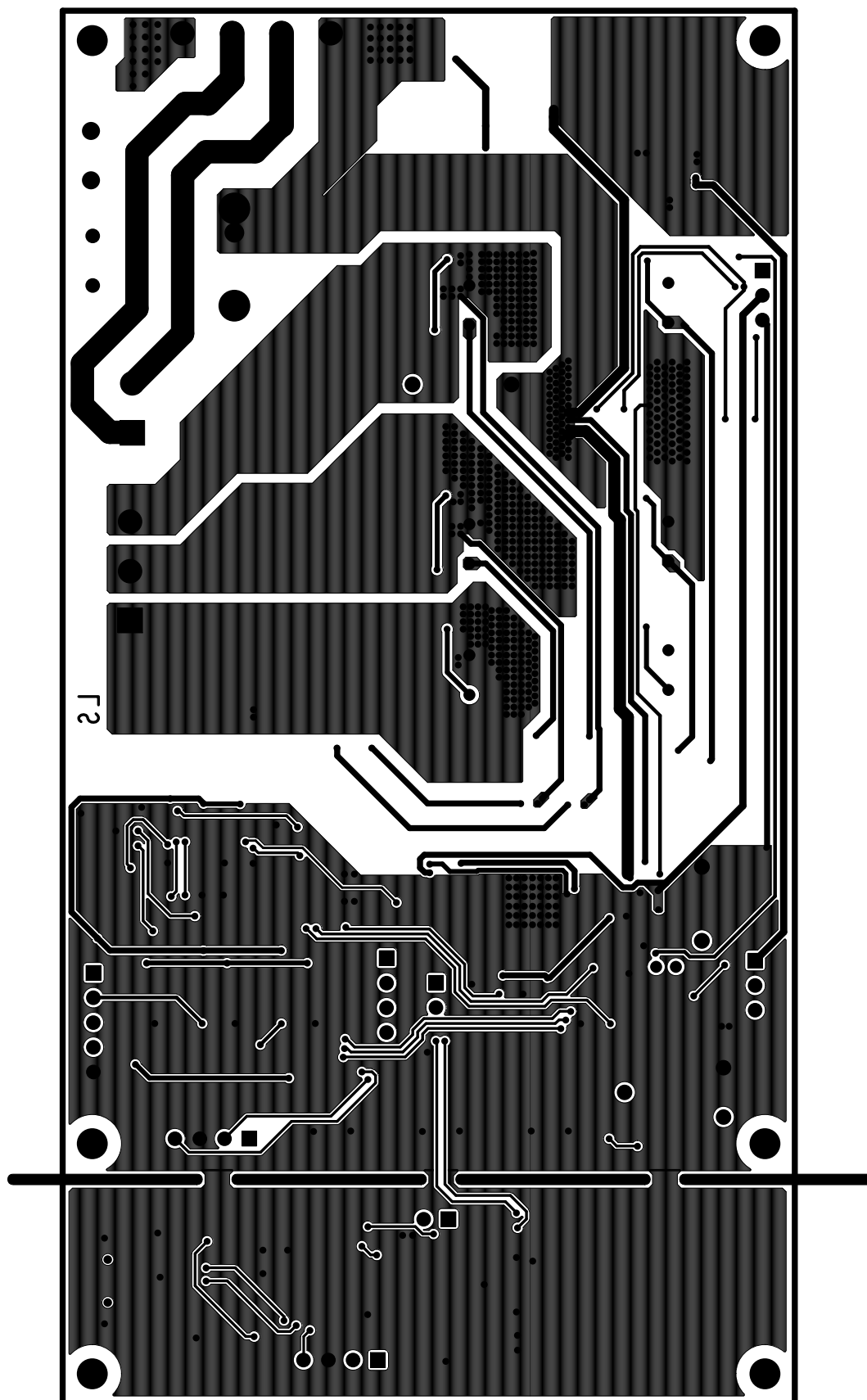

Figure 8. EVSPIN32F0251s – Layout (bottom layer)





## Revision history

**Table 2. Document revision history**

Date	Version	Changes
28-Oct-2019	1	Initial release.

## Contents

<b>1</b>	<b>Safety and operating instructions</b> .....	<b>3</b>
1.1	General terms .....	3
1.2	Intended use of evaluation board .....	3
1.3	Installing the evaluation board .....	3
1.4	Operating the evaluation board .....	3
<b>2</b>	<b>Schematic diagram</b> .....	<b>5</b>
<b>3</b>	<b>Bill of material</b> .....	<b>8</b>
<b>4</b>	<b>Layout and component placements</b> .....	<b>13</b>
	<b>Revision history</b> .....	<b>17</b>
	<b>Contents</b> .....	<b>18</b>
	<b>List of tables</b> .....	<b>19</b>
	<b>List of figures</b> .....	<b>20</b>

## List of tables

<b>Table 1.</b>	Bill of Materials – Components common to all device variants . . . . .	8
<b>Table 2.</b>	Document revision history . . . . .	17

## List of figures

<b>Figure 1.</b>	EVSPIN32F0251S1 schematic – Driver output stage . . . . .	5
<b>Figure 2.</b>	EVSPIN32F0251S1 schematic – Feedback network . . . . .	6
<b>Figure 3.</b>	EVSPIN32F0251S1 schematic – Power Supply . . . . .	7
<b>Figure 4.</b>	EVSPIN32F0251S1 schematic – STLINK debugger . . . . .	7
<b>Figure 5.</b>	EVSPIN32F0251S1 – Board functions description. . . . .	13
<b>Figure 6.</b>	EVSPIN32F0251s – Layout (component placement top view) . . . . .	14
<b>Figure 7.</b>	EVSPIN32F0251s – Layout (top layer) . . . . .	15
<b>Figure 8.</b>	EVSPIN32F0251s – Layout (bottom layer) . . . . .	16

**IMPORTANT NOTICE – PLEASE READ CAREFULLY**

STMicroelectronics NV and its subsidiaries (“ST”) reserve the right to make changes, corrections, enhancements, modifications, and improvements to ST products and/or to this document at any time without notice. Purchasers should obtain the latest relevant information on ST products before placing orders. ST products are sold pursuant to ST’s terms and conditions of sale in place at the time of order acknowledgement.

Purchasers are solely responsible for the choice, selection, and use of ST products and ST assumes no liability for application assistance or the design of Purchasers’ products.

No license, express or implied, to any intellectual property right is granted by ST herein.

Resale of ST products with provisions different from the information set forth herein shall void any warranty granted by ST for such product.

ST and the ST logo are trademarks of ST. For additional information about ST trademarks, please refer to [www.st.com/trademarks](http://www.st.com/trademarks). All other product or service names are the property of their respective owners.

Information in this document supersedes and replaces information previously supplied in any prior versions of this document.

© 2019 STMicroelectronics – All rights reserved