

## Overview

The PHE820M Series is constructed of series winding of metallized polyester encapsulated in self-extinguishing material meeting the requirements of UL 94 V-0.

## Applications

Typical applications include worldwide use in electromagnetic interference suppression in all X2 and across-the-line applications.

## Benefits

- Approvals: ENEC, UL, cUL
- Rated voltage: 275 VAC 50/60 Hz
- Capacitance range: 0.01 – 2.2  $\mu$ F
- Lead spacing: 15.0 – 37.5 mm
- Capacitance tolerance:  $\pm$ 20%,  $\pm$ 10%,  $\pm$ 5% on request
- Climatic category: 40/100/56, IEC 60068-1
- Tape and reel in accordance with IEC 60286-2
- RoHS Compliant and lead-free terminations
- Operating temperature range of -40°C to +100°C
- 100% screening factory test at 2,150 VDC

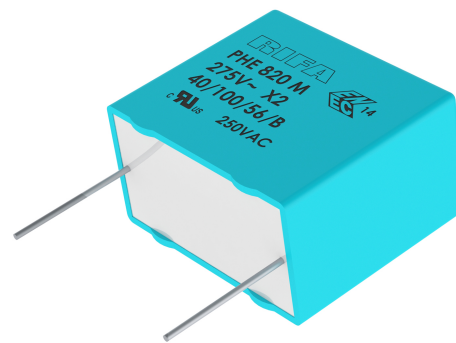

## Legacy Part Number System

PHE820	M	B	5100	M	R17
Series	Rated Voltage (VAC)	Lead Spacing (mm)	Capacitance Code (pF)	Capacitance Tolerance	Packaging
X2, Metallized Polyester	M = 275	B = 15.0 D = 22.5 F = 27.5 R = 37.5	The last three digits represent significant figures. The first digit specifies the total number of digits.	J = $\pm$ 5% K = $\pm$ 10% M = $\pm$ 20%	See Ordering Options Table

## New KEMET Part Number System

F	720	B	D	103	M	275	A
Capacitor Class	Series	Lead Spacing (mm)	Size Code	Capacitance Code (pF)	Capacitance Tolerance	Rated Voltage (VAC)	Packaging
F = Film	X2, Metallized Polyester	B = 15.0 D = 22.5 F = 27.5 R = 37.5	See Dimension Table	First two digits represent significant figures. Third digit specifies number of zeros.	J = $\pm$ 5% K = $\pm$ 10% M = $\pm$ 20%	275 = 275	See Ordering Options Table

## Ordering Options Table

Lead Spacing Nominal (mm)	Type of Leads and Packaging	Lead Length (mm)	KEMET Lead and Packaging Code	Legacy Lead and Packaging Code
15	<b>Standard Lead and Packaging Options</b>			
	Bulk (Bag) – Short Leads	6 +0/-1	C	R06
	Bulk (Bag) – Long Leads	17 +0/-1	A	R17
	<b>Other Lead and Packaging Options</b>			
	Bulk (Bag) – Max Length Leads	30 +5/-0	ALW0L	R30
	Tape & Reel (Standard Reel)	$H_0 = 18.5 \pm 0.5$	L	R17T0
	Tape & Reel (Large Reel)	$H_0 = 18.5 \pm 0.5$	P	R17T1
Native 15 formed to 7.5	Ammo Pack	$H_0 = 16.5 \pm 0.5$	XLAF1	R25XA
	Tape & Reel (Standard Reel)	$H_0 = 16.5 \pm 0.5$	XLTF1	R25X2
22.5	<b>Standard Lead and Packaging Options</b>			
	Bulk (Tray) – Short Leads	6 +0/-1	C	R06L2 <sup>(1)</sup>
	<b>Other Lead and Packaging Options</b>			
	Tape & Reel (Standard Reel)	$H_0 = 18.5 \pm 0.5$	L	R17T0
	Tape & Reel (Large Reel)	$H_0 = 18.5 \pm 0.5$	P	R17T1
	Pizza Pack	6 +0/-1	Z	R06L2 <sup>(1)</sup>
27.5	<b>Standard Lead and Packaging Options</b>			
	Bulk (Tray) – Short Leads	6 +0/-1	C	R06L2 <sup>(1)</sup>
	<b>Other Lead and Packaging Options</b>			
	Tape & Reel (Large Reel)	$H_0 = 18.5 \pm 0.5$	P	R17T1
	Pizza Pack	6 +0/-1	Z	R06L2 <sup>(1)</sup>
37.5	<b>Standard Lead and Packaging Options</b>			
	Bulk (Tray) – Short Leads	6 +0/-1	C	R06L2 <sup>(1)</sup>
	<b>Other Lead and Packaging Options</b>			
	Pizza Pack	6 +0/-1	Z	R06L2 <sup>(1)</sup>

(1) Please specify Bulk (Tray) or Pizza Packaging.

## Dimensions – Millimeters

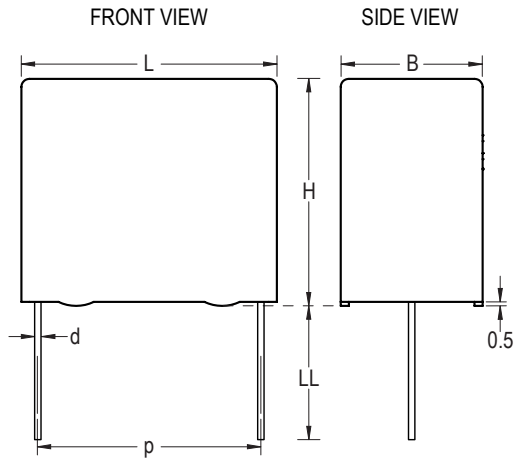

KEMET Size Code	Legacy Size Code	p		B		H		L		d	
		Nominal	Tolerance	Nominal	Tolerance	Nominal	Tolerance	Nominal	Tolerance	Nominal	Tolerance
BD	B04	15	+/-0.4	5.5	Maximum	10.5	Maximum	18.0	Maximum	0.8	+/-0.05
BE	B05	15	+/-0.4	5.5	Maximum	12.5	Maximum	18.0	Maximum	0.8	+/-0.05
BL	B06	15	+/-0.4	7.5	Maximum	14.5	Maximum	18.0	Maximum	0.8	+/-0.05
BJ	B10	15	+/-0.4	6.5	Maximum	12.5	Maximum	18.0	Maximum	0.8	+/-0.05
BQ	B11	15	+/-0.4	8.5	Maximum	16.0	Maximum	18.0	Maximum	0.8	+/-0.05
DD	D13	22.5	+/-0.4	6.5	Maximum	14.5	Maximum	26.0	Maximum	0.8	+/-0.05
DH	D14	22.5	+/-0.4	8.0	Maximum	16.0	Maximum	26.0	Maximum	0.8	+/-0.05
DM	D15	22.5	+/-0.4	9.0	Maximum	18.5	Maximum	26.0	Maximum	0.8	+/-0.05
DT	D16	22.5	+/-0.4	11.0	Maximum	21.5	Maximum	26.0	Maximum	0.8	+/-0.05
FG	F12	27.5	+/-0.4	11.5	Maximum	22.5	Maximum	31.5	Maximum	0.8	+/-0.05
FM	F13	27.5	+/-0.4	14.5	Maximum	24.5	Maximum	31.5	Maximum	0.8	+/-0.05
FR	F14	27.5	+/-0.4	17.5	Maximum	28.0	Maximum	31.5	Maximum	0.8	+/-0.05
RK	R02	37.5	+/-0.4	16.5	Maximum	32.0	Maximum	41.0	Maximum	1	+/-0.05
RM	R03	37.5	+/-0.4	19.0	Maximum	36.0	Maximum	41.0	Maximum	1	+/-0.05

Note: See Ordering Options Table for lead length (LL) options.



## Performance Characteristics

Rated Voltage	275 VAC 50/60 Hz	
Capacitance Range	0.01 – 2.2 $\mu$ F	
Capacitance Tolerance	$\pm$ 20%, $\pm$ 10%, $\pm$ 5% on request	
Temperature Range	-40°C to +100°C	
Climatic Category	40/100/56	
Approvals	ENEC, UL, cUL	
Dissipation Factor	Maximum Values at +23°C	
	1 kHz	1.0%
Test Voltage Between Terminals	The 100% screening factory test is carried out at 2,150 VDC. The voltage level is selected to meet the requirements in applicable equipment standards. All electrical characteristics are checked after the test. It is not permitted to repeat this test as there is a risk to damage the capacitor. KEMET is not liable in such case for any failures.	
Insulation Resistance	Minimum Values Between Terminals	
	$C \leq 0.33 \mu\text{F}$	$\geq 30,000 \text{ M}\Omega$
	$C > 0.33 \mu\text{F}$	$\geq 10,000 \text{ M}\Omega \cdot \mu\text{F}$
In DC Applications	Recommended voltage $\leq$ 760 VDC	

## Environmental Test Data

Test	IEC Publication	Procedure
Endurance	EN/IEC 60384-14	$1.25 \times V_R$ VAC 50 Hz, once every hour increase to 1,000 VAC for 0.1 second, 1,000 hours at upper rated temperature
Vibration	IEC 60068-2-6 Test Fc	3 directions at 2 hours each 10 – 55 Hz at 0.75 mm or 98 m/s <sup>2</sup>
Bump	IEC 60068-2-29 Test Eb	1,000 bumps at 390 m/s <sup>2</sup>
Change of Temperature	IEC 60068-2-14 Test Na	Upper and lower rated temperature 5 cycles
Active Flammability	IEC 60384-14	$V_R + 20$ surge pulses at 2.5 kV (pulse every 5 seconds)
Passive Flammability	IEC 60384-14	IEC 60384-1, IEC 60695-11-5 Needle Flame Test
Damp Heat Steady State	IEC 60068-2-78 Test Cab	+40°C and 93% RH, 56 days

## Approvals

Mark	Specification	File Number
	EN/IEC 60384-14	SE/0140-12E
	UL 1414 (up to 1 $\mu$ F, 85°C, 250 VAC)	E73869
	CSA – C22.2 No. 1 (up to 1 $\mu$ F, 85°C, 250 VAC)	E73869
	UL 1283 (310 VAC)	E100117
	CSA – C22.2 No. 8 (310 VAC)	E100117

## Environmental Compliance

All KEMET EMI capacitors are RoHS Compliant.

### Table 1 – Ratings & Part Number Reference

Capacitance Value ( $\mu$ F)	Size Code (New/Legacy)	Max Dimensions in mm			Lead Spacing (p)	f <sub>o</sub> (MHz)	dV/dt (V/ $\mu$ s)	New KEMET Part Number	Legacy Part Number
		B	H	L					
0.010	BD/B04	5.5	10.5	18.0	15	13	100	F720BD103(1)275(2)	PHE820MB5100(1)(2)
0.015	BD/B04	5.5	10.5	18.0	15	11	100	F720BD153(1)275(2)	PHE820MB5150(1)(2)
0.022	BD/B04	5.5	10.5	18.0	15	9.0	100	F720BD223(1)275(2)	PHE820MB5220(1)(2)
0.033	BE/B05	5.5	12.5	18.0	15	7.5	100	F720BE333(1)275(2)	PHE820MB5330(1)(2)
0.047	BJ/B10	6.5	12.5	18.0	15	6.5	100	F720BJ473(1)275(2)	PHE820MB5470(1)(2)
0.068	BL/B06	7.5	14.5	18.0	15	5.5	100	F720BL683(1)275(2)	PHE820MB5680(1)(2)
0.10	BQ/B11	8.5	16.0	18.0	15	4.5	100	F720BQ104(1)275(2)	PHE820MB6100(1)(2)
0.10	DD/D13	6.5	14.5	26.0	22.5	4.5	100	F720DD104(1)275(2)	PHE820MD6100(1)(2)
0.15	DH/D14	8.0	16.0	26.0	22.5	3.9	100	F720DH154(1)275(2)	PHE820MD6150(1)(2)
0.22	DM/D15	9.0	18.5	26.0	22.5	2.7	100	F720DM224(1)275(2)	PHE820MD6220(1)(2)
0.33	DT/D16	11.0	21.5	26.0	22.5	2.5	100	F720DT334(1)275(2)	PHE820MD6330(1)(2)
0.47	FG/F12	11.5	22.5	31.5	27.5	1.9	100	F720FG474(1)275(2)	PHE820MF6470(1)(2)
0.68	FM/F13	14.5	24.5	31.5	27.5	1.6	100	F720FM684(1)275(2)	PHE820MF6680(1)(2)
1.0	FR/F14	17.5	28.0	31.5	27.5	1.3	100	F720FR105(1)275(2)	PHE820MF7100(1)(2)
1.5	RK/R02	16.5	32.0	41.0	37.5	0.75	100	F720RK155(1)275(2)	PHE820MR7150(1)(2)
2.2	RM/R03	19.0	36.0	41.0	37.5	0.65	100	F720RM225(1)275(2)	PHE820MR7220(1)(2)
Capacitance Value ( $\mu$ F)	Size Code (New/Legacy)	B (mm)	H (mm)	L (mm)	Lead Spacing (p)	f <sub>o</sub> (MHz)	dV/dt (V/ $\mu$ s)	New KEMET Part Number	Legacy Part Number

(1) M =  $\pm 20\%$ , K =  $\pm 10\%$ , J =  $\pm 5\%$  on request.

(2) Insert ordering code for lead type and packaging. See Ordering Options Table for available options.

## Soldering Process

The implementation of the RoHS directive has resulted in the selection of SnAgCu (SAC) alloys or SnCu alloys as primary solder. This has increased the liquidus temperature from that of 183°C for SnPb eutectic alloy to 217 – 221°C for the new alloys. As a result, the heat stress to the components, even in wave soldering, has increased considerably due to higher pre-heat and wave temperatures. Polypropylene capacitors are especially sensitive to heat (the melting point of polypropylene is 160 – 170°C). Wave soldering can be destructive, especially for mechanically small polypropylene capacitors (with lead spacing of 5 mm to 15 mm), and great care has to be taken during soldering. The recommended solder profiles from KEMET should be used. Please consult KEMET with any questions. In general, the wave soldering curve from IEC Publication 61760-1 Edition 2 serves as a solid guideline for successful soldering. Please see Figure 1.

Reflow soldering is not recommended for through-hole film capacitors. Exposing capacitors to a soldering profile in excess of the above the recommended limits may result to degradation or permanent damage to the capacitors.

Do not place the polypropylene capacitor through an adhesive curing oven to cure resin for surface mount components. Insert through-hole parts after the curing of surface mount parts. Consult KEMET to discuss the actual temperature profile in the oven, if through-hole components must pass through the adhesive curing process. A maximum two soldering cycles is recommended. Please allow time for the capacitor surface temperature to return to a normal temperature before the second soldering cycle.

### Manual Soldering Recommendations

Following is the recommendation for manual soldering with a soldering iron.

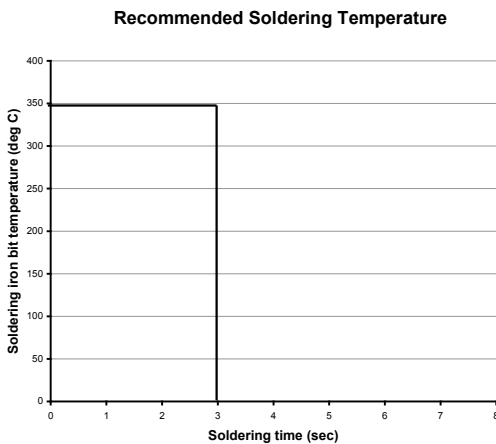

The soldering iron tip temperature should be set at 350°C (+10°C maximum) with the soldering duration not to exceed more than 3 seconds.

### Wave Soldering Recommendations

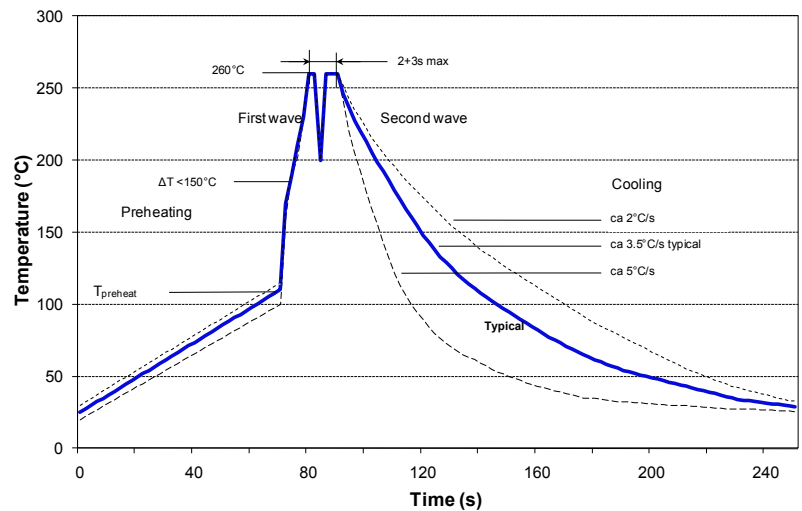

## Soldering Process cont'd

### Wave Soldering Recommendations cont'd

1. The table indicates the maximum set-up temperature of the soldering process

Figure 1

Dielectric Film Material	Maximum Preheat Temperature			Maximum Peak Soldering Temperature	
	Capacitor Pitch ≤ 10 mm	Capacitor Pitch = 15 mm	Capacitor Pitch > 15 mm	Capacitor Pitch ≤ 15 mm	Capacitor Pitch > 15 mm
Polyester	130°C	130°C	130°C	270°C	270°C
Polypropylene	100°C	110°C	130°C	260°C	270°C
Paper	130°C	130°C	140°C	270°C	270°C
Polyphenylene Sulphide	150°C	150°C	160°C	270°C	270°C

2. The maximum temperature measured inside the capacitor:

Set the temperature so that inside the element the maximum temperature is below the limit:

Dielectric Film Material	Maximum temperature measured inside the element
Polyester	160°C
Polypropylene	110°C
Paper	160°C
Polyphenylene sulphide	160°C

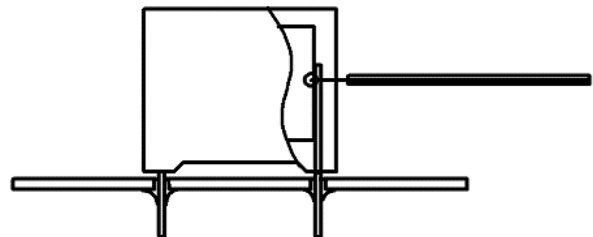

Temperature monitored inside the capacitor.

### Selective Soldering Recommendations

Selective dip soldering is a variation of reflow soldering. In this method, the printed circuit board with through-hole components to be soldered is preheated and transported over the solder bath as in normal flow soldering without touching the solder. When the board is over the bath, it is stopped and pre-designed solder pots are lifted from the bath with molten solder only at the places of the selected components, and pressed against the lower surface of the board to solder the components.

The temperature profile for selective soldering is similar to the double wave flow soldering outlined in this document, **however, instead of two baths, there is only one bath with a time from 3 to 10 seconds.** In selective soldering, the risk of overheating is greater than in double wave flow soldering, and great care must be taken so that the parts are not overheated.

## Construction

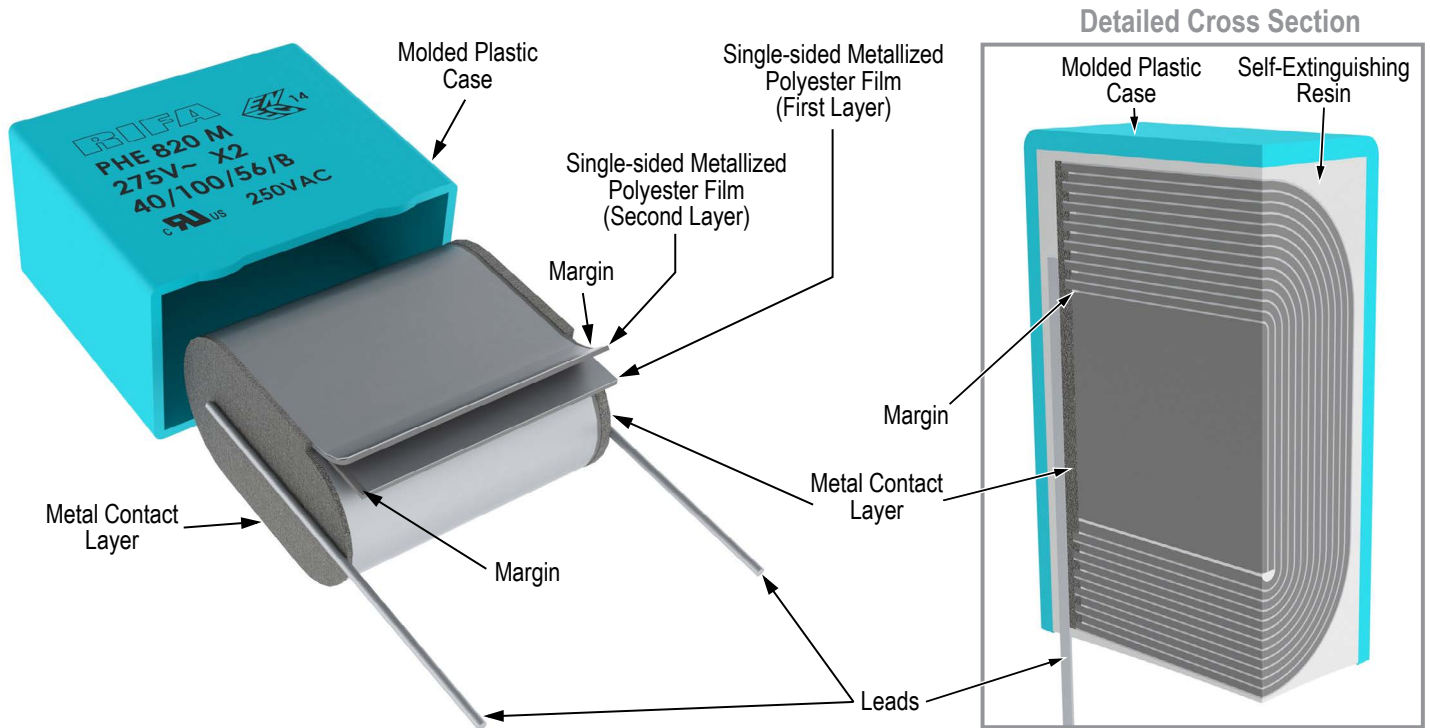

## Winding Scheme

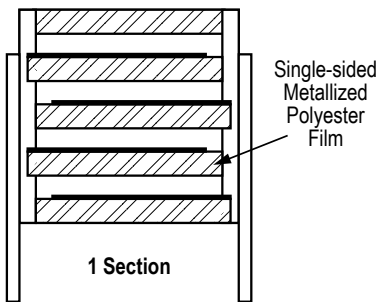



## Marking

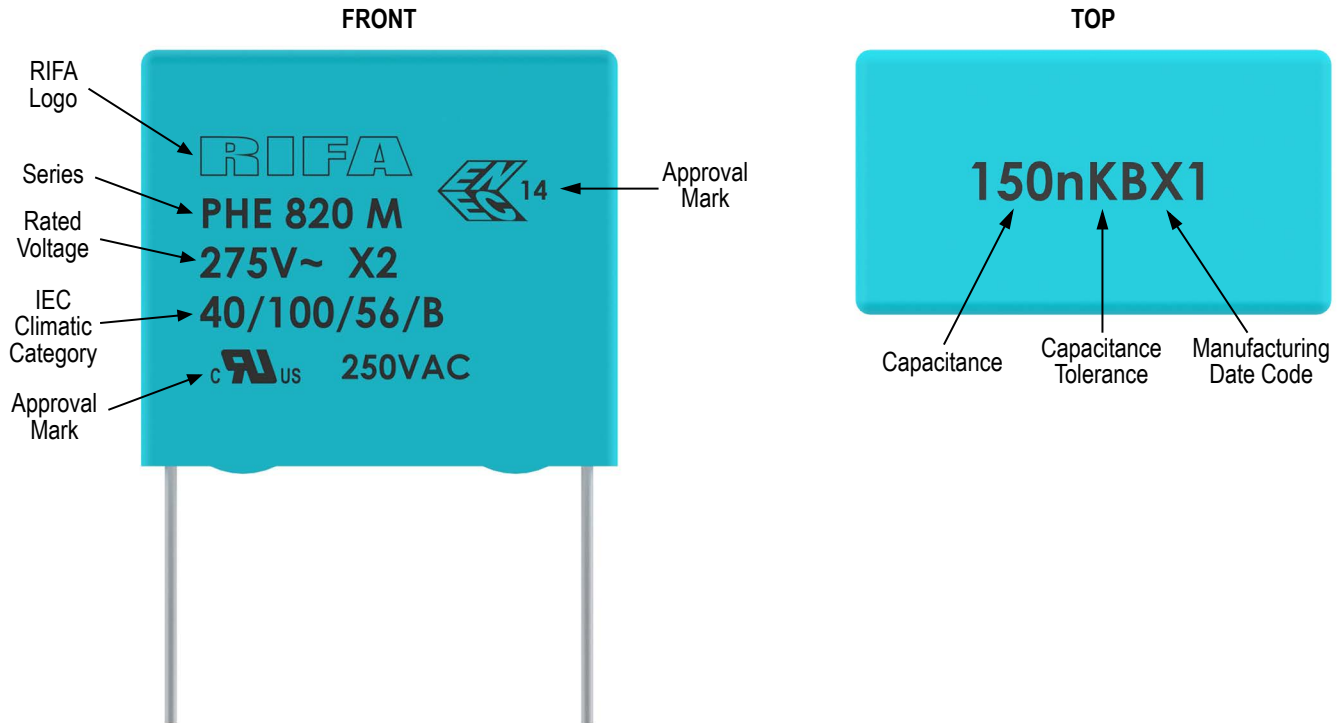

## Packaging Quantities

KEMET Size Code	Legacy Size Code	Lead Spacing	Thickness (mm)	Height (mm)	Length (mm)	Bulk Short Leads	Bulk Long Leads	Standard Reel ø 360 mm	Large Reel ø 500 mm	Pizza	Standard Reel Formed	Ammo Formed
BD	B04	15	5.5	10.5	18	1000	800	600	1200		550	570
BE	B05		5.5	12.5	18	1000	800	600	1200		550	570
BL	B06		7.5	14.5	18	800	400	400	800		350	378
BJ	B10		6.5	12.5	18	1000	600	500	1000		450	480
BQ	B11		8.5	16	18	600	400	400	800		350	324
BM	B12		8	15	18	600	400	400	800		350	351
BV	B14		9.5	17.5	18	500	300	350	700		250	297
BG	B15		6	12	18	1000	800	500	1000		450	520
BY	B16		11	19	18	450	250	300	600		250	252
BU	B17		13	12.5	18	400	300	250	500		200	216
DD	D13	22.5	6.5	14.5	26.5	234		300	600	440		
DH	D14		8	16	26.5	186		250	500	352		
DM	D15		9	18.5	26.5	308		250	500	308		
DT	D16		11	21.5	26.5	253		200	400	253		
DF	D17		7	16.5	26.5	216		300	600	396		
DR	D18		10.5	19	26.5	264		200	400	264		
DY	D19		15.5	24.5	26.5	176		110	250	176		
DW	D20		13.5	23	26.5	209		160	300	209		
FK	F03	27.5	13.5	23	31.5	171			250	171		
FE	F11		10.5	20.5	31.5	216			350	216		
FG	F12		11.5	22.5	31.5	198			300	198		
FM	F13		14.5	24.5	31.5	153			250	153		
FR	F14		17.5	28	31.5	126				126		
FS	F15		19	29	31.5	117				117		
FV	F16		21	30	31.5	108				108		
FH	F17		21	12.5	31.5	108				108		
FT	F18		31	18.5	31.5	72				72		
FQ	F19		27.5	16	31.5	81				81		
RK	R02	37.5	16.5	32	41	105				105		
RM	R03		19	36	41	91				91		
RH	R04		15	26	41	119				119		
RF	R05		13	24	41	140				140		
RP	R06		21	38	41	84				84		
RS	R08		28	43	41	54				54		

## Lead Taping & Packaging (IEC 60286–2)

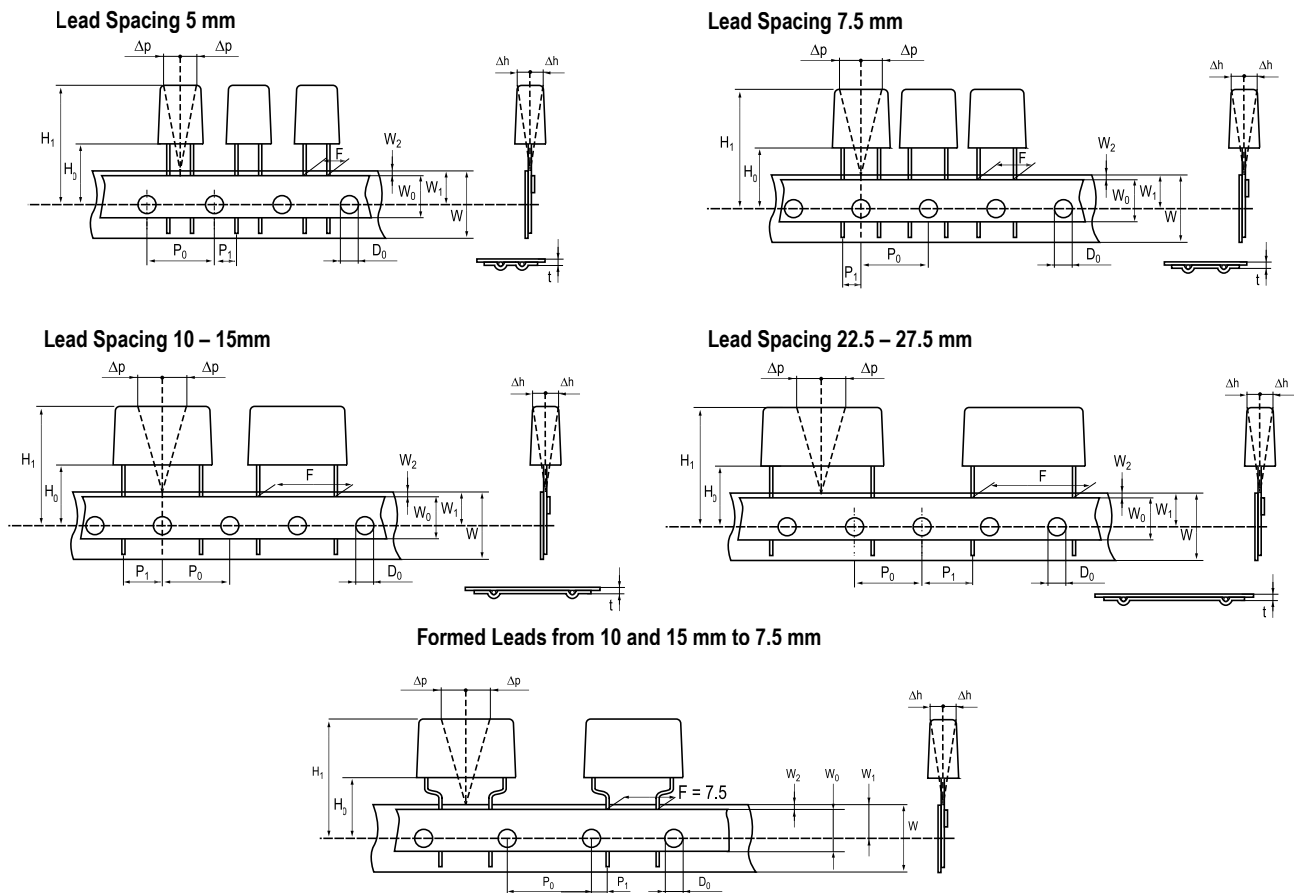

## Taping Specification

Dimensions in mm										Standard IEC 60286–2
Lead spacing	+6/-0.1	F	5	7.5	Formed 7.5	10	15	22.5	27.5	F
Carrier tape width	+/-0.5	W	18	18	18	18	18	18	18	18 <sup>+1/-0.5</sup>
Hold-down tape width	+/-0.3	W <sub>0</sub>	9	9	9	12	12	12	12	
Position of sprocket hole	+/-0.5	W <sub>1</sub>	9	9	9	9	9	9	9	9 <sup>+0.75/-0.5</sup>
Distance between tapes	Maximum	W <sub>2</sub>	3	3	3	3	3	3	3	3
Sprocket hole diameter	+/-0.2	D <sub>0</sub>	4	4	4	4	4	4	4	4
Feed hole lead spacing	+/-0.3	P <sub>0</sub> <sup>(1)</sup>	12.7	12.7	12.7 <sup>(4)</sup>	12.7	12.7	12.7	12.7	12.7
Distance lead – feed hole	+/-0.7	P <sub>1</sub>	3.85	3.75	3.75	7.7	5.2	5.3	5.3	P <sup>1</sup>
Deviation tape – plane	Maximum	$\Delta p$	1.3	1.3	1.3	1.3	1.3	1.3	1.3	1.3
Lateral deviation	Maximum	$\Delta h$	2	2	2	2	2	2	2	2
Total thickness	+/-0.2	t	0.7	0.7	0.7	0.7	0.7	0.9 <sup>MAX</sup>	0.9 <sup>MAX</sup>	0.9 <sup>MAX</sup>
Sprocket hole/cap body	Nominal	H <sub>0</sub> <sup>(2)</sup>	18.5 <sup>+/-0.5</sup>	18.5 <sup>+/-0.5</sup>	18.5 <sup>+/-0.5</sup>	18.5 <sup>+/-0.5</sup>	18.5 <sup>+/-0.5</sup>	18.5 <sup>+/-0.5</sup>	18.5 <sup>+/-0.5</sup>	18 <sup>+2/-0</sup>
Sprocket hole/top of cap body	Maximum	H <sub>1</sub> <sup>(3)</sup>	32	31	43	43	43	58	58	58 <sup>MAX</sup>

(1) Maximum cumulative feed hole error, 1 mm per 20 parts.

(2) 16.5 mm available on request.

(3) Depending on case size.

(4) 15 mm available on request.

## Lead Taping & Packaging (IEC 60286–2) cont'd

### Ammo Specifications

Series	Dimensions (mm)		
	H	W	T
R4x, R4x+R, R7x, RSB	360	340	59
F5A, F5B, F5D			
F6xx, F8xx			
PHExxx, PMExxx, PMRxxx, SMR & PFR	330	330	50

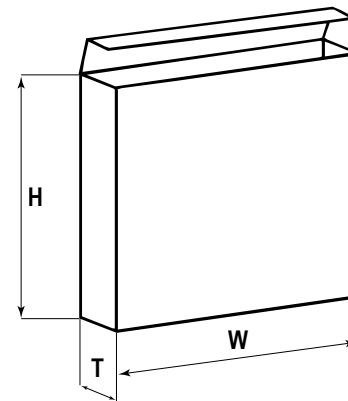

### Reel Specifications

Series	Dimensions (mm)		
	D	H	W
R4x, R4x+R, R7x, RSB	355 500	30 25	55 (Max)
F5A, F5B, F5D			
F6xx, F8xx			
PHExxx, PMExxx, PMRxxx, SMR & PFR	360 500	30	46 (Max)

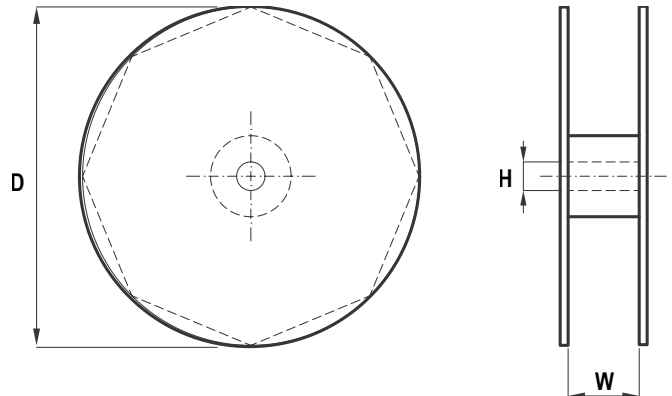

### Manufacturing Date Code (IEC–60062)

Y = Year, Z = Month			
Year	Code	Month	Code
2000	M	January	1
2001	N	February	2
2002	P	March	3
2003	R	April	4
2004	S	May	5
2005	T	June	6
2006	U	July	7
2007	V	August	8
2008	W	September	9
2009	X	October	O
2010	A	November	N
2011	B	December	D
2012	C		
2013	D		
2014	E		
2015	F		
2016	H		
2017	J		
2018	K		
2019	L		
2020	M		

## KEMET Corporation World Headquarters

2835 KEMET Way  
Simpsonville, SC 29681

Mailing Address:  
P.O. Box 5928  
Greenville, SC 29606

www.kemet.com  
Tel: 864-963-6300  
Fax: 864-963-6521

**Corporate Offices**  
Fort Lauderdale, FL  
Tel: 954-766-2800

## North America

### Southeast

Lake Mary, FL  
Tel: 407-855-8886

### Northeast

Wilmington, MA  
Tel: 978-658-1663

### Central

Novi, MI  
Tel: 248-306-9353

### West

Milpitas, CA  
Tel: 408-433-9950

### Mexico

Guadalajara, Jalisco  
Tel: 52-33-3123-2141

## Europe

### Southern Europe

Sasso Marconi, Italy  
Tel: 39-051-939111

Skopje, Macedonia  
Tel: 389-2-55-14-623

### Central Europe

Landsberg, Germany  
Tel: 49-8191-3350800

Kamen, Germany  
Tel: 49-2307-438110

### Northern Europe

Harlow, United Kingdom  
Tel: 44-1279-460122

Espoo, Finland  
Tel: 358-9-5406-5000

## Asia

### Northeast Asia

Hong Kong  
Tel: 852-2305-1168

Shenzhen, China  
Tel: 86-755-2518-1306

Beijing, China  
Tel: 86-10-5877-1075

Shanghai, China  
Tel: 86-21-6447-0707

Seoul, South Korea  
Tel: 82-2-6294-0550

Taipei, Taiwan  
Tel: 886-2-27528585

### Southeast Asia

Singapore  
Tel: 65-6701-8033

Penang, Malaysia  
Tel: 60-4-6430200

Bangalore, India  
Tel: 91-806-53-76817

*Note: KEMET reserves the right to modify minor details of internal and external construction at any time in the interest of product improvement. KEMET does not assume any responsibility for infringement that might result from the use of KEMET Capacitors in potential circuit designs. KEMET is a registered trademark of KEMET Electronics Corporation.*

## Disclaimer

All product specifications, statements, information and data (collectively, the "Information") in this datasheet are subject to change. The customer is responsible for checking and verifying the extent to which the Information contained in this publication is applicable to an order at the time the order is placed.

All Information given herein is believed to be accurate and reliable, but it is presented without guarantee, warranty, or responsibility of any kind, expressed or implied.

Statements of suitability for certain applications are based on KEMET Electronics Corporation's ("KEMET") knowledge of typical operating conditions for such applications, but are not intended to constitute – and KEMET specifically disclaims – any warranty concerning suitability for a specific customer application or use. The Information is intended for use only by customers who have the requisite experience and capability to determine the correct products for their application. Any technical advice inferred from this Information or otherwise provided by KEMET with reference to the use of KEMET's products is given gratis, and KEMET assumes no obligation or liability for the advice given or results obtained.

Although KEMET designs and manufactures its products to the most stringent quality and safety standards, given the current state of the art, isolated component failures may still occur. Accordingly, customer applications which require a high degree of reliability or safety should employ suitable designs or other safeguards (such as installation of protective circuitry or redundancies) in order to ensure that the failure of an electrical component does not result in a risk of personal injury or property damage.

Although all product-related warnings, cautions and notes must be observed, the customer should not assume that all safety measures are indicated or that other measures may not be required.