

OSCONIQ® S3030 1 LED PowerStar CRI 80

ILH-S601-xx80-SC221-WIR200.

Product Overview

At the heart of each PowerStar is an OSRAM OSCONIQ® S3030 Series LED, which has a CRI rating of 80. Thanks to their extremely high colour efficacy and brightness, OSCONIQ® S3030 enables lesser volume LED usage and smaller PCB design. Complete portfolio with industrial standard footprint of 3mm x 3mm. PowerStars are compact, powerful LED light sources built on aluminium substrates for optimal thermal management. Available with 200mm wires as standard.



Applications

- Area Lights
- Highbay Industrial
- General Lighting
- Architectural Lighting
- Research and Development
- Spot Lights
- Stage Lighting
- Retrofits and Fixtures

Technical Features

- Up to 100,000 hours lifetime to 70% of original brightness
- High Efficacy enable better energy saving
- OSCONIQ® S3030 PowerStars contain OSCONIQ® S3030 LEDs from OSRAM Opto Semiconductors with integral 120 degree silicone resin Lenses
- Secondary Lens can be fitted – check options in Lens and Reflector section
- Suitable Heatsinks available – check options in Heatsink section
- Suitable Thermal Interface Material available - check options in Thermal Interface Material section
- Suitable Power Supplies available - check options in Power Supply section
- Mounting holes using M3 screws allow easy installation
- Available with 200mm connecting wires
- Size (LxHxW): 20x20x2.25mm
- PowerStars can be linked together to produce longer chains
- Current range: 10mA to 200mA
- CRI 80

*This datasheet should be read in conjunction with the relevant OSRAM Opto Semiconductors data on the LED used

Important Information and Precautions

- PowerStars, when powered up, are very bright. Thus it is advised that you do not look directly at them. Turn the PowerStar product away from you and do not shine into the eyes of others.
- PowerStar products will overheat in operation if not attached to a suitable Heatsink. Overheating can cause failure or irreparable damage.
- Do not operate PowerStar products with a Power Supply with unlimited current. Connection to constant voltage Power Supplies that are not current limited may cause the PowerStar product to consume current above the specified maximum and cause failure or irreparable damage.
- PowerStar products, when operated, can reach high temperatures thus there is risk of injury if they are touched.
- DO NOT HOT PLUG ON LED SIDE OF POWER SUPPLY
- DO NOT TOUCH or PUSH on the LED as this might cause irreparable damage.

Product Options

ILS Part Number	Colour	Colour Temp (Degrees Kelvin) *	Typical Wattage at 150mA §	Forward Voltage	Flux † at 150mA	Radiance Angle	Relevant OSRAM LED Data
ILH-S601-HW80-SC221-WIR200.	Hot White	2700K	0.96W	5.80V to 6.60V	125 lm	120 ° (+/- 60°)	GWQSLR31.EM
ILH-S601-WM80-SC221-WIR200.	Warm White	3000K	0.96W	5.80V to 6.60V	130 lm	120 ° (+/- 60°)	GWQSLR31.EM
ILH-S601-QZ80-SC221-WIR200.	Quartz White	3500K	0.96W	5.80V to 6.60V	135 lm	120 ° (+/- 60°)	GWQSLR31.EM
ILH-S601-NU80-SC221-WIR200.	Neutral White	4000K	0.96W	5.80V to 6.60V	135 lm	120 ° (+/- 60°)	GWQSLR31.EM
ILH-S601-WH80-SC221-WIR200.	White	5000K	0.96W	5.80V to 6.60V	135 lm	120 ° (+/- 60°)	GWQSLR31.EM
ILH-S601-SW80-SC221-WIR200.	Street White	5700K	0.96W	5.80V to 6.60V	135 lm	120 ° (+/- 60°)	GWQSLR31.EM
ILH-S601-UL80-SC221-WIR200.	Ultra White	6000K	0.96W	5.80V to 6.60V	130 lm	120 ° (+/- 60°)	GWQSLR31.EM

* Due to the special conditions of the manufacturing processes of LEDs, the typical data of technical parameters can only reflect statistical figures and do not necessarily correspond to the actual parameters of each single product which could differ from the typical data.

§ Tolerance +/- 10%

† Measured with 150mA pulse at 85 °c

Minimum and Maximum Ratings

ILS PART NUMBER	Operating Temperature at Tc-Point [°C]*	Storage Temperature [°C]*	Forward Current per chip [mA]*	Reverse Voltage [Vdc]*
ILH-S601-HW80-SC221-WIR200.	-40 ... 100 (°C)	-40 ... 100 (°C)	10mA ... 200mA	Not designed for reverse operation
ILH-S601-WM80-SC221-WIR200.	-40 ... 100 (°C)	-40 ... 100 (°C)	10mA ... 200mA	Not designed for reverse operation
ILH-S601-QZ80-SC221-WIR200.	-40 ... 100 (°C)	-40 ... 100 (°C)	10mA ... 200mA	Not designed for reverse operation
ILH-S601-NU80-SC221-WIR200.	-40 ... 100 (°C)	-40 ... 100 (°C)	10mA ... 200mA	Not designed for reverse operation
ILH-S601-WH80-SC221-WIR200.	-40 ... 100 (°C)	-40 ... 100 (°C)	10mA ... 200mA	Not designed for reverse operation
ILH-S601-SW80-SC221-WIR200.	-40 ... 100 (°C)	-40 ... 100 (°C)	10mA ... 200mA	Not designed for reverse operation
ILH-S601-UL80-SC221-WIR200.	-40 ... 100 (°C)	-40 ... 100 (°C)	10mA ... 200mA	Not designed for reverse operation

* Exceeding maximum ratings for operating and storage temperature will reduce expected life time or destroy the LED module. Exceeding maximum ratings for operating voltage will cause hazardous overload and is likely to destroy the LED module. The temperature of the LED module must be measured at the Tc-Point according to EN60598-1 in a thermally constant status with a temperature sensor or a temperature sensitive label.

Radiation of single LED

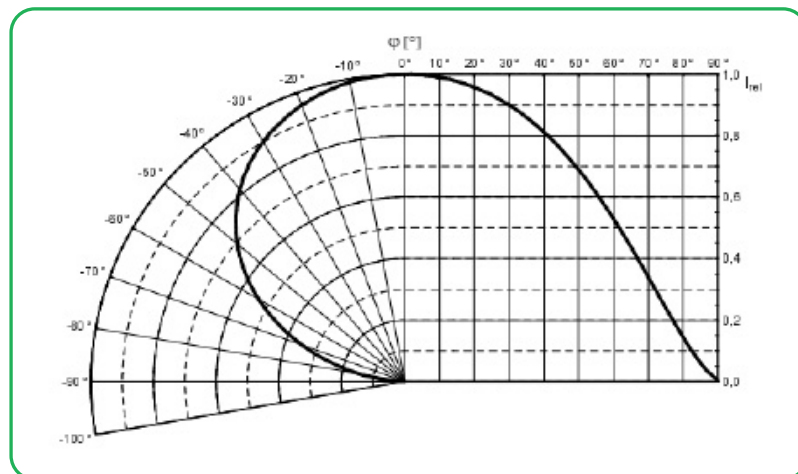

Technical Drawing

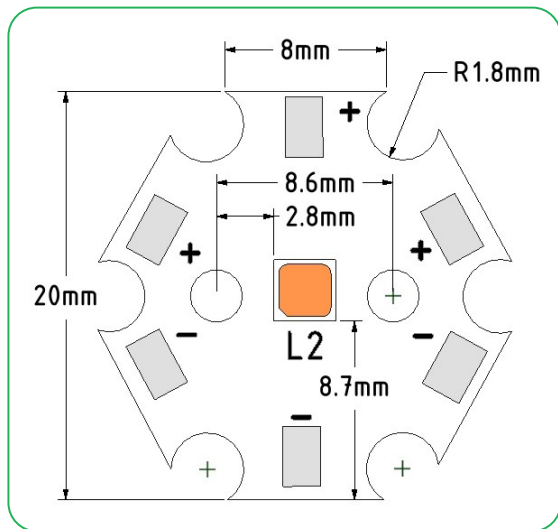

3D Drawing

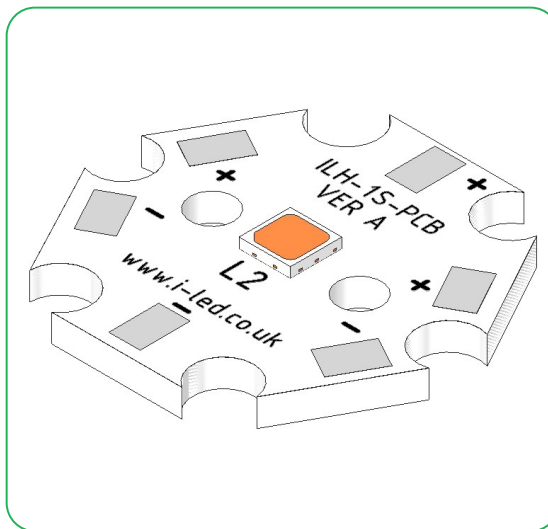

3D drawing files are available on request from ILS. Please call or email

Lens and Reflector Options

LEDiL precision-engineered Lenses and Reflectors allow for rapid deployment of all types of light fixtures, including street lights, wall-wash, high-bay, sconces, emergency beacons, parking garage/low-bay, MR and AR down lights, and dock lights. Precision-engineered for maximum efficiency and durability, LEDiL Lenses and Reflectors are released alongside the latest product releases from our LED suppliers. You select the best LED for the application; choose LEDiL and you're selecting the best optical solution as well.



Ordering Code	Beam	Diameter	Height	Family	FWHM	Material	Colour	Fastening
CP12946_LARISA-WW-CLIP8	Wide	9.9mm	7.5mm	LARISA	+/- 55	PMMA	Black	glue, clips
CP12947_LARISA-WW-CLIP16	Wide	9.9mm	7.5mm	LARISA	+/- 50	PMMA	Black	glue, clips
CP12940_LARISA-M-CLIP8	Medium	9.9mm	7.5mm	LARISA	+/- 30	PMMA	Black	clips
CP12941_LARISA-M-CLIP16	Medium	9.9mm	7.5mm	LARISA	+/- 34	PMMA	Black	clips
CP12942_LARISA-O-CLIP8	Oval	9.9mm	7.5mm	LARISA	26 + 41	PMMA	Black	clips
CP12943_LARISA-O-CLIP16	Oval	9.9mm	7.5mm	LARISA	26 + 41	PMMA	Black	clips
CP15308_LARISA-WW-PIN	Wide	9.9mm	7.5mm	LARISA	+/- 55	PMMA	Black	glue, pin
CP15309_LARISA-RZ-PIN	Diffused	9.9mm	7.5mm	LARISA	+/- 25	PMMA	Black	glue, pin
CP12944_LARISA-W-CLIP8	Wide	9.9mm	7.5mm	LARISA	+/- 50	PMMA	Black	glue, clips
CP12945_LARISA-W-CLIP16	Wide	9.9mm	7.5mm	LARISA	+/- 50	PMMA	Black	glue, clips
CP13666_LARISA-RZ-CLIP16	Diffused	9.9mm	7.5mm	LARISA	+/- 25	PMMA	Black	clips
CP12413_LOS-D	Diffused	21.6mm	14.3mm	LOS	+/- 14	PMMA	White	glue, pin
CP12414_LOS-M	Medium	21.6mm	14.3mm	LOS	+/- 25	PMMA	White	glue, pin
FA11204_TINA-O	Oval	16.1mm	9.5mm	TINA	35 x 15	PMMA	Black	tape, pin
FA11205_TINA-D	Diffused Spot	16.1mm	9.5mm	TINA	+/- 16	PMMA	Black	tape, pin
FA11206_TINA-M	Medium	16.1mm	9.5mm	TINA	+/- 30	PMMA	Black	tape, pin
CA12375_TINA2-D	Diffused Spot	16mm	9.5mm	TINA2	+/- 16	PMMA	Black	tape, pin
CA12376_TINA2-SS	Spot	16mm	9.5mm	TINA2	+/- 18	PMMA	Black	tape, pin
CA12377_TINA2-M	Medium	16mm	9.5mm	TINA2	+/- 30	PMMA	Black	tape, pin
CA12379_TINA2-O	Oval	16mm	9.5mm	TINA2	35 + 15	PMMA	Black	tape, pin
C13253_TINA2-R-CLIP16	Reflector	16.1mm	10.1mm	TINA2	+/- 60	HRPC	White	clips
FA11826_TINA3-WWW	Wide	16.1mm	6.9mm	TINA3	+/- 70	PMMA	White	tape, pin

Heatsink Options

ILS has a series of Aluminium Alloy Heatsinks to be used with our standard range of PowerStars, PowerClusters and PowerLinear Engines. These Heatsinks are supplied with fixing screws for the light engine and for fixing to a base plate. They also come with Thermal Interface Material (TIM) attached to the top surface. More versions will be introduced over the coming months and we are also happy to manufacture custom Heatsinks to your request.

ILS Product	Current	No Heatsink, in free air	ILA-HSINK-STAR-50X20MM	ILA-HSINK-STAR-50X40MM	ILA-HSINK-STAR-50X60MM	ILA-HSINK-STAR-50X80MM	ILA-HSINK-70X70X55MM	ILA-HSINK-78X46X25MM
OSCONIQ® S3030 PowerStars	150mA	Yellow	Green	Green	Green	Green	Green	Green

Green	Operates under the recommended ILS junction temperature
Yellow	Operates under the recommended LED maximum junction temperature
Red	Not suitable for use
N/A	Heatsink not designed for use with this product

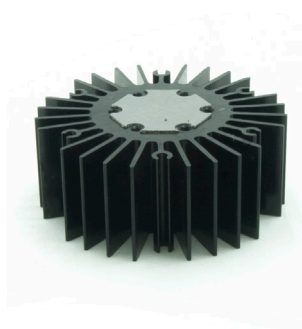

Power Supply Option

ILS has a comprehensive range of standard Power Supplies. The table below shows forward voltage of each LED driver please consult the product options table to find the forward voltage of the PowerStar used.

Additional Power Supplies are being introduced so please call us or check our website for the latest offering.

To determine how many PowerStars can be used with each LED driver you will need the following. Forward voltage of the PowerStar and forward voltage of the LED Driver.

For example ILH-S601-WM70-SC221-WIR200. forward voltage of 5.8V-6.6V (this can be found under Product Options page 2) and ILA-1CH-LED-TESTER-PREC-01. has an output voltage of 20V.

To determine the minimum number of PowerStars this driver can run take the minimum output voltage of the Driver 20V and divide by the forward minimum voltage of the PowerStar 5.8V - $20 \div 5.8 = 3.44$ PowerStars.

To determine the maximum number of PowerStars this driver can run take the maximum forward voltage 20V and divide this by the maximum forward voltage of the PowerStar 6.6V - $20 \div 6.6 = 3.03$ PowerStars.

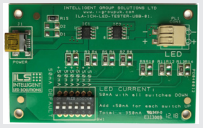
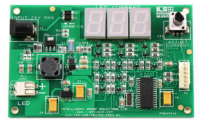
ILS Driver Part Number	Rating Watts	Output	Output Volts	Dimming	
ILA-1CH-LED-TESTER-USB-01.	5	50-350mA* do not use above 200mA	5	No	
ILA-1CH-LED-TESTER-PREC-01	16.8	10-700mA* do not use above 200mA	20	YEs	

Thermal Interface Material Options

ILS have produced a range of high-performance, cost effective Thermal Interface Materials to match perfectly their standard products. Our product fills the air pockets between the two surfaces, forming a continuous layer to conduct heat away from the LED to the Heatsink.

Product	Non Adhesive	Single Sided Adhesive	Double Sided Adhesive
Star	ILA-TIM-STAR-0A	ILA-TIM-STAR-1A	ILA-TIM-STAR-2A

Other sizes are available, including customised parts

Assembly Information

- The mounting of the OSCONIQ® S3030 PowerStar has to be on a metal Heatsink.
- In order to optimise the thermal management, the metal surface needs to be clean (dirt and oil free) and planar for the best contact with the LED module. A thermal grease or heat transfer material is highly recommended.

Safety Information

- The LED module itself and all its components must not be mechanically stressed.
- Assembly must not damage or destroy conducting paths on the circuit board.
- The mounting of the module is carried out by attaching it at the mounting holes. Metal mounting screws must be insulated with synthetic washers to prevent circuit board damage and possible short circuiting.
- To avoid mechanical damage to the connecting cables, the boards should be attached securely to the intended substrate. Heavy vibration should be avoided.
- Observe correct polarity!
- Depending on the product, incorrect polarity will lead to emission of red or no light. The module can be destroyed!
- Pay attention to standard ESD precautions when installing the OSCONIQ® S3030 PowerStar.
- The OSCONIQ® S3030 PowerStars, as manufactured, have no conformal coating and therefore offer no inherent protection against corrosion.
- Damage by corrosion will not be accepted as a materials defect claim. It is the user's responsibility to provide suitable protection against corrosive agents such as moisture and condensation and other harmful elements.
- For outdoor usage, a housing is definitely required to protect the board against environmental influences. The design of the housing must correspond to the IP standards in the application. It is also the responsibility of the user to ensure any housings or modifications keep the Tc junction temperature to within stated ranges.
- To also ease the luminaire/installation approval, electronic control gear for LED or LED modules should carry the CE mark and be ENEC certified. In Europe the declarations of conformity must include the following standards: CE: EC 61374-2-13, EN 55015, IEC 61547 and IEC 61000-3-2 - ENEC: 61374-2-13 and IEC/EN 62384.
- The evaluation of eye safety occurs according to the standard IEC 62471:2006 ("photobiological safety of lamps and lamp systems"). Within the risk grouping system of this CIE standard, the LED specified in this data sheet falls into the class "moderate risk" (exposure time 0.25s). Under real circumstances (for exposure time, eye pupils, observation distance), it is assumed that no endangerment to the eye exists from these devices. As a matter of principle, however, it should be mentioned that intense light sources have a high secondary exposure potential due to their blinding effect. As is also true when viewing other bright light sources (e.g. headlights), temporary reduction in visual acuity and afterimages can occur, leading to irritation, annoyance, visual impairment and even accidents, depending on the situation.

For further information please contact ILS

The values contained in this datasheet can change due to technical innovations. Any such changes will be made without separate notification.