



# Dimmable Constant Current LED Drivers

## IZC0xx-018T Series

IZC0xx-018T Series are a range of RoHS compliant single output Constant Current power supplies, of non waterproof design, suitable for indoor LED lighting applications with triac dimming function.



## CONTENTS

Technical Features	<a href="#">page 2</a>	LED Configuration	<a href="#">page 3</a>
Product Options	<a href="#">page 2</a>	Technical Drawings	<a href="#">page 3</a>

## TECHNICAL FEATURES

IP Rating	IP20
Input Voltage	220-240V
Input Frequency	50Hz to 60Hz
Power Factor	0.95
Efficiency	Higher than 80%
Set Up Time	< 2s
Over Load Protection	100-135% of rated output power
Over Temperature Protection	Thermal shutdown
Dimming Control	Triac controlled 1-100%
Storage Temperature	-20°C to +80°C
Lifetime	50K hours full load 25°C
Safety Standards	Designed to meet EN61347-1:2001/EN61347-2-13:2001
EMI Standards	Meets Emissions to EN 55105,EN61547
Weight	108g
Input Connection	Screw terminal
Output Connections	Screw terminal

## PRODUCT OPTIONS

ILS PART NUMBER	Voltage	Current	Power	LED Config.	Operating Temperature	Dimensions
IZC070-018T-9500A-SX	13-26V	700mA	18W	5-8 White LEDs	-20°C to +50°C	L130xW43xH28mm
IZC050-018T-9500A-SX	18-36V	500mA	18W	6-12 White LEDs	-20°C to +50°C	L130xW43xH28mm
IZC035-018T-9500A-SX	26-52V	350mA	18W	5-14 White LEDs	-20°C to +50°C	L130xW43xH28mm

# LED CONFIGURATION

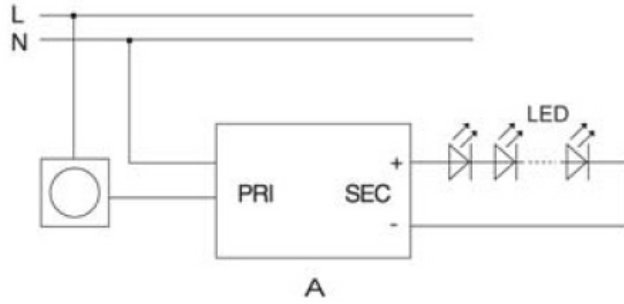

## TECHNICAL DRAWING (MM)

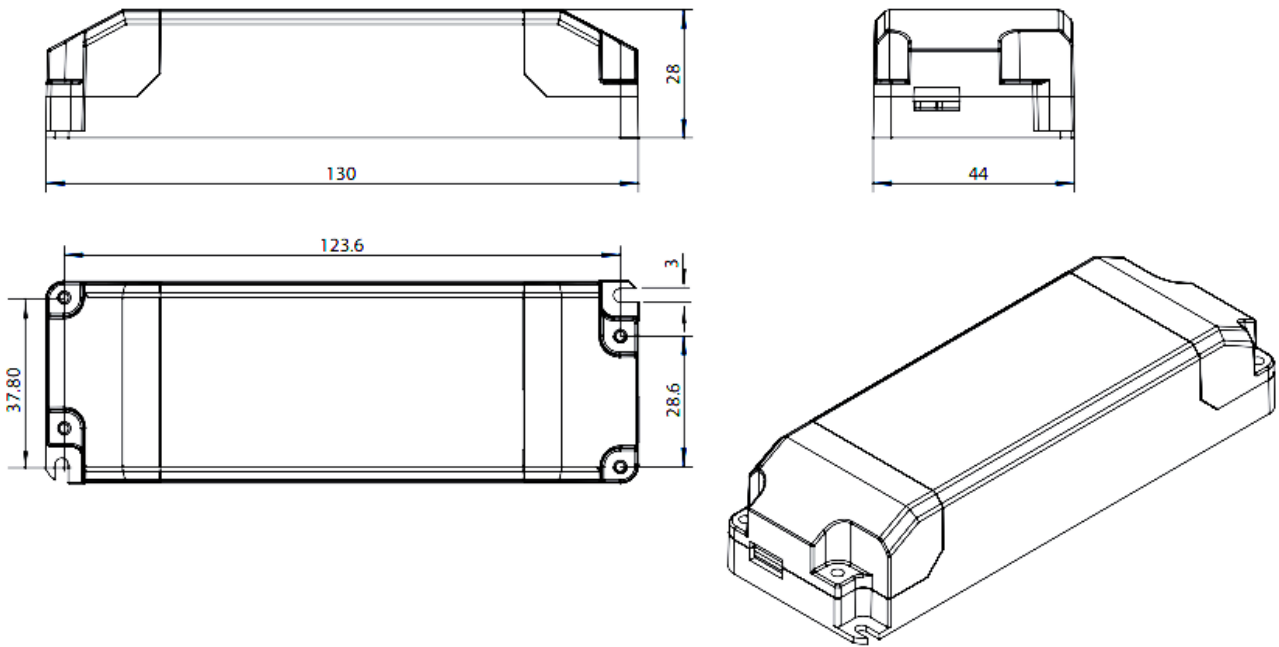

## FURTHER INFORMATION

The values contained in this datasheet can change due to technical innovation. Any such changes will be made without separate notification.

If you require further assistance or have a specific or custom enquiry, please contact the ILS team via email or phone. Alternatively please visit our website for more product information and to see our full ranges.



Unit 2, Berkshire Business Centre,  
Berkshire Drive, Thatcham,  
Berkshire, RG19 4EW  
+44 (0)1635 294606

[info@i-led.co.uk](mailto:info@i-led.co.uk)

<https://i-led.co.uk>

## ABOUT ILS

ILS offers a high level of technical skill, professionalism and commercial understanding to companies requiring market-leading optoelectronics solutions. Offering conceptual advice, electronics design and manufacturing capability, we use high quality production resources both in-house and in Asia, providing project support from prototyping to mass production. We also understand the need to provide cost effective solutions and we do so using high quality components to ensure that the end product's reliability and quality is uncompromised. Apart from LEDs in the visible spectrum, we have a wide range of [Infrared](#), [UV LEDs](#), [UV tubes](#), and lasers.

ILS is a division of [Intelligent Group Solutions Ltd \(IGS\)](#) a well-established respected industry leading optoelectronics solutions provider. Much of IGS' business comes from providing semi-custom or custom products both in component and sub-assembly form, and from providing design support and prototyping within the European market place. We can deliver production displays to wherever in the world that the customer's manufacturing or assembly is being undertaken.

## INTELLIGENT GROUP SOLUTIONS DIVISIONS

