

Panel Mount Adaptor for Keystones



Panel Mount Adaptor for Keystones (KAPMA#20)

These adaptors enable most keystones to be mounted easily into panels of virtually any thickness.

Features

- Die cast adaptor is robust and ensures easy mounting (into standard cut-out) and reliable earthing
- Supplied with 2 pairs of screws
 - 2 x round head nickel-plated steel self-tapping screws. T3.0x10
 - 2 x round head nickel-plated steel machine screws. (4.40 x 1/4") M3x6

Specifications

- Weight: 12g approx. each
Packs of 20: 245g approx
- Dimensions: 35.50 x 19.12 x 9.80 mm
- Colour: Silver
- Material: Nickel plated zinc alloy



Packaging: Supplied in bags of 20

EAN: 5055386501967

Commodity Code: 85177090

ROHS Compliant

Code: KAPMA#20

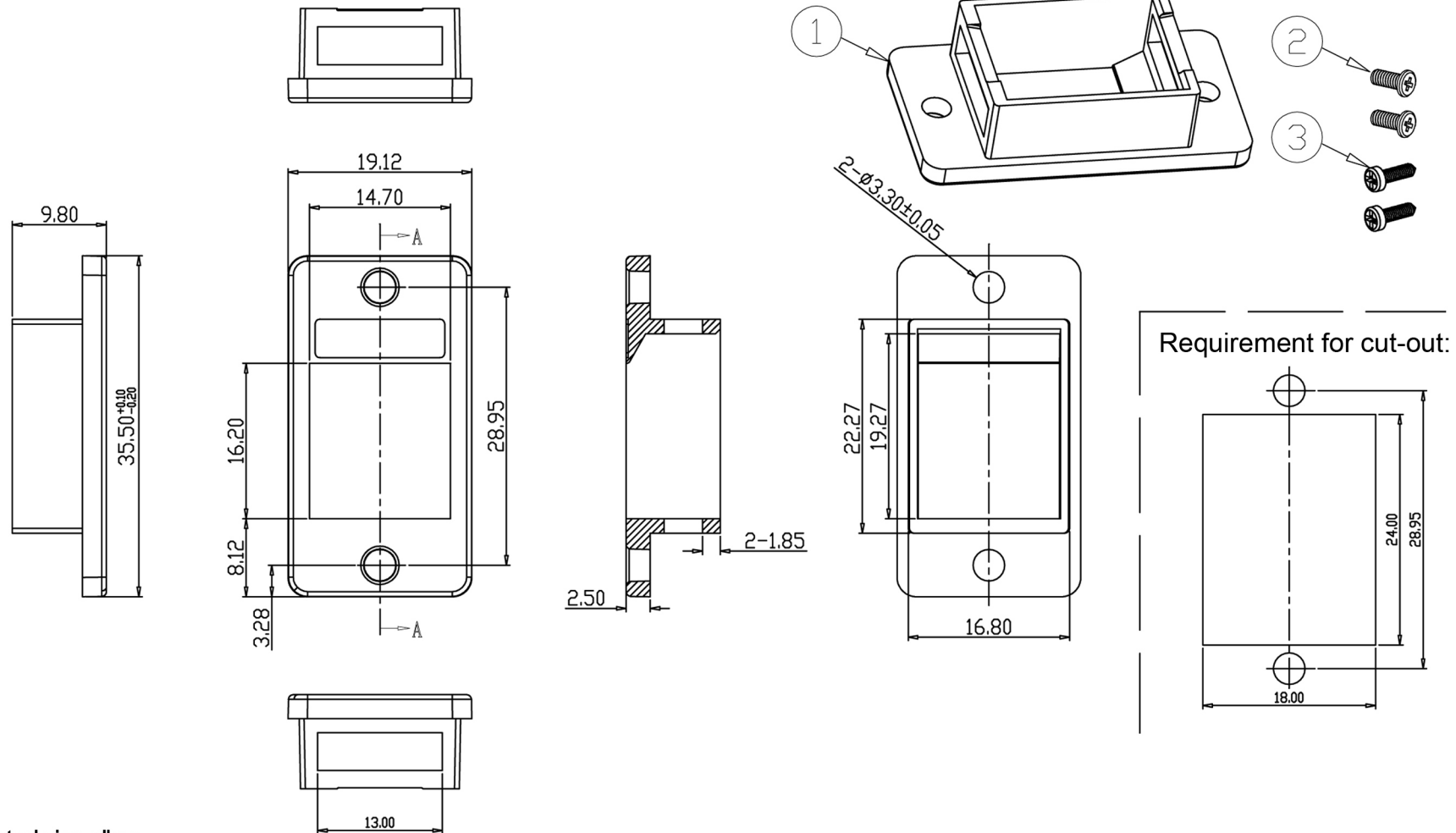

Materials:

- 1. Nickel plated zinc alloy
- 2&3. Nickel plated steel