

MDCL0165C0-0048R0SHZ DATASHEET



MODEL	MDCL0165C0-0048R0SHZ
--------------	-----------------------------

Version	Revision of historical records
V2019-1 Trial Version	First Edition
V2020-1	Version Update
V2020-2	Version Update
V2021-1	Version Update

FEATURES

- Compact, fully enclosed splash proof design
- Over 1,000,000 duty cycles
- High power density

APPLICATIONS

- Automotive
- Railway transportation
- Heavy duty machinery
- Energy storage system

SPECIFICATIONS

Electrical	Characteristics
Nominal Capacitance	165 F
Capacitance Tolerance	0% / +20%
Rated Voltage	48 V
Surge Voltage	51 V
ESR,DC	5 mΩ
Maximum Continuous Current ($\Delta T=15^{\circ}\text{C}$)	90 A
Maximum Continuous Current ($\Delta T=40^{\circ}\text{C}$)	150 A
Maximum Peak Current,1sec.	2000 A
Leakage Current(25°C , after 72 h,Excluding equalizing current)	5.2 mA
Equalizing current	125 mA
Cell	CDCL3000C0-0002R7WLH
Number of Cells	18
Environment	
Operating Temperature Range	$-40^{\circ}\text{C} \sim +65^{\circ}\text{C}$
Storage Temperature Range	$-40^{\circ}\text{C} \sim +70^{\circ}\text{C}$
Environment Humidity	$\leq 96\%RH$
Physical	
Weight	14.8 kg
Power Terminals	M8/M10
Recommended Torque-Terminal	20/30 N·m
Vibration Specification	GB/T 11287-2000
Shock Specification	GB/T 14537-1993
Environment Protection	IP65
Monitoring/Cell Voltage Management	
Cell Voltage Monitoring	Overvoltage Alarm
Temperature	NTC Thermistor

SPECIFICATIONS

Power And Energy

Usable Power Density (Pd)	3736 W/kg
---------------------------	-----------

Impedance Match Power Density(Pmax)	7783 W/kg
-------------------------------------	-----------

Gravimetric Energy Density(Emax)	3.6 Wh/kg
----------------------------------	-----------

Stored Energy	52.8 Wh
---------------	---------

Life

High Temperature Life (at Rated Voltage & Maximum Operating Temperature)	1500 hours
--	------------

Capacitance Change (%decrease from specified value)	≤20%
---	------

ESR Change (%increase from specified value)	≤100%
--	-------

Room Temperature Life (at Rated Voltage at 25°C)	10 years
---	----------

Capacitance Change (%decrease from specified value)	≤20%
---	------

ESR Change (%increase from specified value)	≤100%
--	-------

Cycle Life (Number of cycles)	1,000,000
----------------------------------	-----------

Capacitance Change (%decrease from specified value)	≤20%
---	------

ESR Change (%increase from specified value)	≤100%
--	-------

Shelf Life (25°C, uncharged)	4 years
---------------------------------	---------

Safe

Factory High-Pot Test	2500 VDC
-----------------------	----------

Thermal Characteristics

Typical Thermal Resistance	0.3°C/W
----------------------------	---------

Typical Thermal Capacitance	14000 J/°C
-----------------------------	------------

NOTES

1. Surge voltage is non-repetitive. The duration must not exceed 1 second.
2. Maximum peak current in non-repetitive. The duration must not exceed 1 second.
3. Formula of maximum peak current:

$$I_{peak} = \frac{1 / 2CV}{C \times ESR_{DC} + 1}$$

C is rated capacity, V is rated voltage.

4. Formula of power and energy:

Usable Power Density :

$$P_d = \frac{0.12V^2}{ESR_{DC} \times mass}$$

Gravimetric Energy Density:

$$E_{max} = \frac{1 / 2CV^2}{3600 \times mass}$$

Impedance Match Power Density:

$$P_{max} = \frac{V^2}{4ESR_{DC} \times mass}$$

Stored Energy:

$$E = \frac{1 / 2CV^2}{3600}$$

MEASURING METHOD

- 1) Charge and Discharge procedure (Figure 1)
 - a) Charge the capacitor using constant current I to rated voltage V_0 ;
 - b) Keep rated voltage 5 min;
 - c) Discharge the capacitor using constant current I to half rated voltage, record discharge time T_1 during voltage change from V_1 to V_2 ;
 - d) Rest 2-5s, record voltage change ΔV ;
 - e) Discharge it to a very low voltage around 0.01V;
 - f) $V_1=80\% V_0, V_2=50\% V_0$;

2) Capacitance

$$C = I * T_1 / (V_1 - V_2)$$

C: Capacitance(F);

I : Constant Discharge Current(A);

T_1 : Discharge Time(s);

V_1-V_2 : Voltage Change (V).

3) DC ESR

$$DC\ ESR = \Delta V / I$$

DC ESR: DC Equivalent Series Resistance(Ω)

ΔV : Voltage Change(V);

I: Constant Discharge Current (A);

4) AC ESR

Measure AC ESR using LCR meter

Frequency: 1KHz;

Voltage: fully discharge

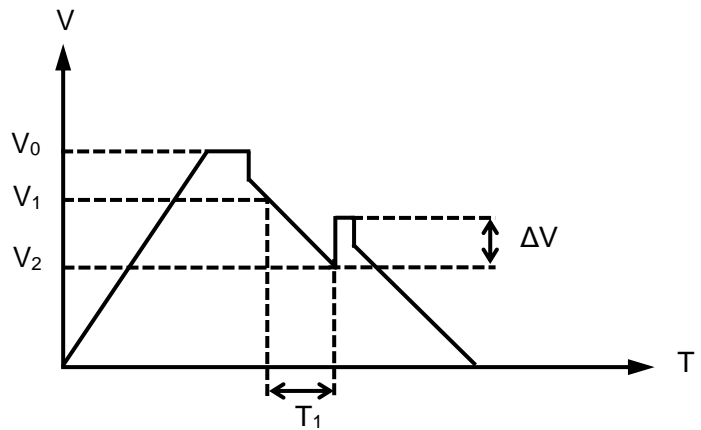
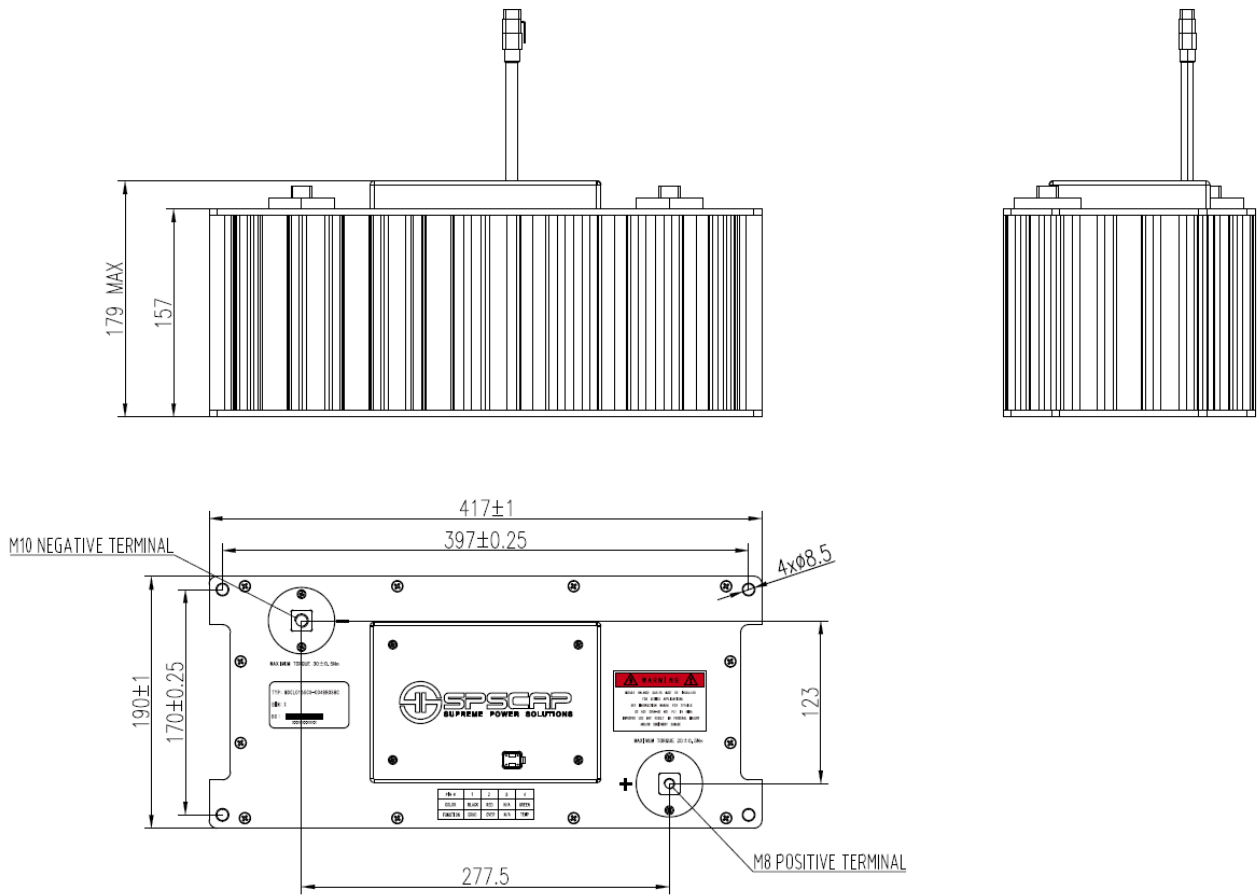

Figure 1

Pin Number	Wire Color	Definition	Output
1	Black	GND	
2	Red	Overvoltage Alarm	High - Inactive
			Low - Active
3	Void	Void	
4	Green	Temperature	

DIMENSIONS



MODEL	Dimension(mm)		
	L(±1)	W(±1)	H(Max)
MDCL0165C0-0048R0SHZ	417	190	179

All rights reserved. Design and specifications are subjected to change without notice.

NINGBO CRRC NEW ENERGY TECHNOLOGY CO.,LTD.

Add: No.199 Shidai Road,Wuxiang Town,Yinzhou District,
Ningbo,Zhejiang,China

Email: info@spscap.com

Website: www.spscap.com

