

# MDCL0222C0-0051R0SHZ DATASHEET



<b>MODEL</b>	<b>MDCL0222C0-0051R0SHZ</b>
--------------	-----------------------------

<b>Version</b>	<b>Revision of historical records</b>
V2022-1 Trial Version	First Edition

## FEATURES

- Compact, fully enclosed splash proof design
- Over 500,000 duty cycles
- High power density

## APPLICATIONS

- Automotive
- Railway transportation
- Heavy duty machinery
- Energy storage system

## SPECIFICATIONS

### Electrical

Nominal Capacitance	222F
Capacitance Tolerance	0% / +20%
Rated Voltage	51 V
Surge Voltage	54 V
ESR,DC	5.2 mΩ
Maximum Peak Current,1sec.	2627 A
Leakage Current(25 °C , after 72 h,Excluding equalizing current)	14.5 mA

Cell	CDCL4000C0-002R85WLZ
Number of Cells	18

### Environment

Operating Temperature Range	-40 °C ~+65 °C
Storage Temperature Range	-40 °C ~+70 °C
Environment Humidity	≤96%RH

### Physical

Weight	14.4 kg
Power Terminals	M8/M10
Recommended Torque-Terminal	20 N·m (M8)/30 N·m(M10)
Vibration Specification	SAE J2380, ISO 16750-3 Table 12
Shock Specification	SAE J2464
Environment Protection	IP54

### Monitoring/Cell Voltage Management

Cell Voltage Monitoring	Overvoltage Alarm
Temperature Sensor	NTC Thermistor
Connector	Deutsch DTM04-4P

## SPECIFICATIONS

### Power And Energy

Usable Power Density (Pd)	4168 W/kg
---------------------------	-----------

Impedance Match Power Density(Pmax)	8683 W/kg
-------------------------------------	-----------

Gravimetric Energy Density(Emax)	5.5 Wh/kg
----------------------------------	-----------

Stored Energy	80.1 Wh
---------------	---------

### Life

High Temperature Life (at Rated Voltage & Maximum Operating Temperature )	1500 hours
--	------------

Capacitance Change (%decrease from specified value )	$\leq 20\%$
---	-------------

ESR Change (%increase from specified value)	$\leq 100\%$
--	--------------

Room Temperature Life (at Rated Voltage at 25°C)	10 years
---	----------

Capacitance Change (%decrease from specified value )	$\leq 20\%$
---	-------------

ESR Change (%increase from specified value)	$\leq 100\%$
--	--------------

Cycle Life (Number of cycles)	500,000
----------------------------------	---------

Capacitance Change (%decrease from specified value )	$\leq 20\%$
---	-------------

ESR Change (%increase from specified value)	$\leq 100\%$
--	--------------

Shelf Life (25°C, uncharged)	4 years
---------------------------------	---------

### Safe

Factory High-Pot Test	2500 VDC
-----------------------	----------

**NOTES**

1. Surge voltage is non-repetitive. The duration must not exceed 1second.
2. Maximum peak current in non-repetitive. The duration must not exceed 1second.
3. Formula of maximum peak current:

$$I_{peak} = \frac{1 / 2CV}{C \times ESR_{DC} + 1}$$

C is rated capacity, V is rated voltage.

4. Formula of power and energy:

Usable Power Density :

$$P_d = \frac{0.12V^2}{ESR_{DC} \times mass}$$

Impedance Match Power Density:

$$P_{max} = \frac{V^2}{4ESR_{DC} \times mass}$$

Gravimetric Energy Density:

$$E_{max} = \frac{1 / 2CV^2}{3600 \times mass}$$

Stored Energy:

$$E = \frac{1 / 2CV^2}{3600}$$

## MEASURING METHOD

- 1) Charge and Discharge procedure (Figure 1)
  - a) Charge the capacitor using constant current I to rated voltage  $V_0$ ;
  - b) Keep rated voltage 5 min;
  - c) Discharge the capacitor using constant current I to half rated voltage, record discharge time  $T_1$  during voltage change from  $V_1$  to  $V_2$ ;
  - d) Rest 2-5s, record voltage change  $\Delta V$ ;
  - e) Discharge it to a very low voltage around 0.01V;
  - f)  $V_1=80\% V_0, V_2=50\% V_0$ ;

2) Capacitance

$$C = I * T_1 / (V_1 - V_2)$$

C: Capacitance(F);

I : Constant Discharge Current(A);

$T_1$ : Discharge Time(s);

$V_1-V_2$ : Voltage Change (V).

3) DC ESR

$$DC\ ESR = \Delta V / I$$

DC ESR: DC Equivalent Series Resistance( $\Omega$ )

$\Delta V$ : Voltage Change(V);

I: Constant Discharge Current (A);

4) AC ESR

Measure AC ESR using LCR meter

Frequency: 1KHz;

Voltage: fully discharge

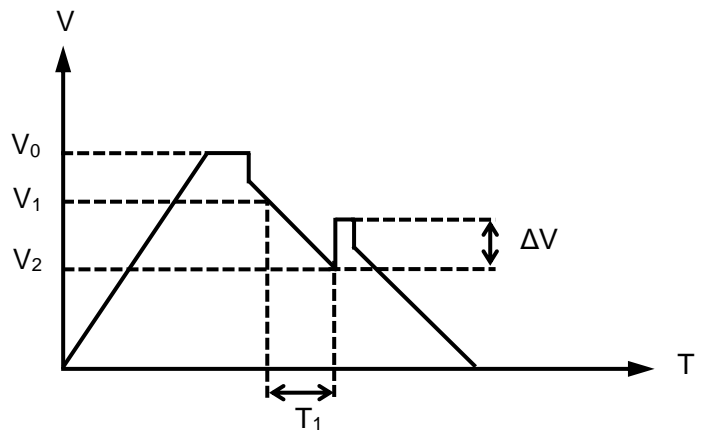
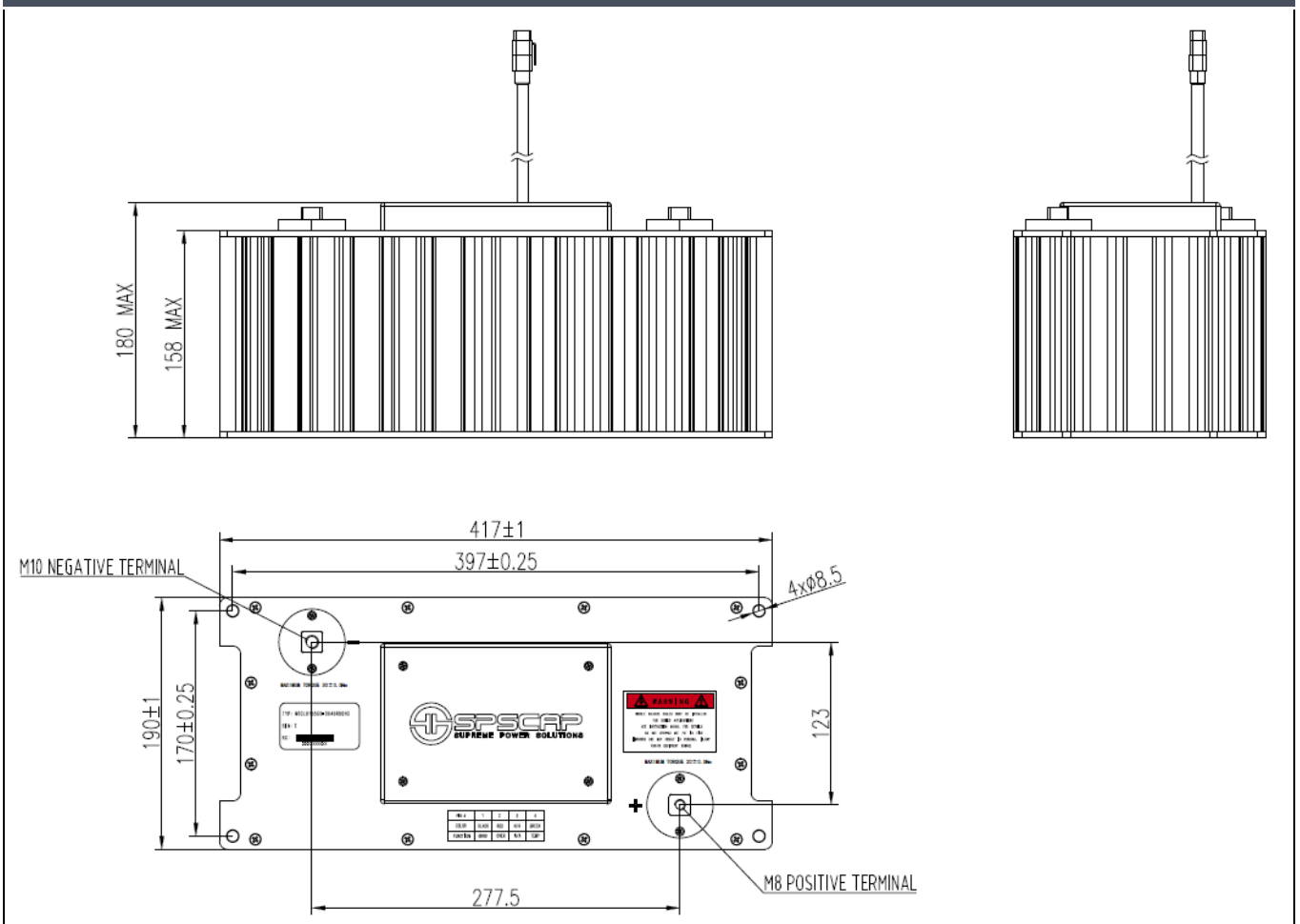

Figure 1

Pin Number	Wire Color	Definition	Output
1	Black	GND	
2	Red	Overvoltage Alarm	High - Inactive
			Low - Active
3	Void	Void	
4	Green	Temperature	

## DIMENSIONS



MODEL	Dimension(mm)		
	L(±1)	W(±1)	H(Max)
MDCL0222C0-0051R0SHZ	417	190	180

All rights reserved. Design and specifications are subjected to change without notice.

NINGBO CRRC NEW ENERGY TECHNOLOGY CO.,LTD.

Add: No.199 Shidai Road,Wuxiang Town,Yinzhou District,  
Ningbo,Zhejiang,China

Email: info@spscap.com

Website: www.spscap.com

