

THIS IS A C.A.D. GENERATED DRAWING
DO NOT MAKE MANUAL REVISIONS TO MASTER.

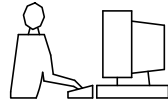

* UNLESS OTHERWISE SPECIFIED TOLERANCES
ON DECIMAL IS:

DRAWING UPDATED ③
Johnny DEC.04-2020
DRAWING UPDATED ④
Johnny March.15-2022

BACKSHELL KIT INCLUDES:

- (2)BACKSHELL HALVES
- (2)4-40 THUMBSCREWS
- (2)HOUSING SCREWS & (2)NUTS
- (1)SET OF COMPRESSION INSERTS-VARIOUS SIZES
DIAMETERS:4mm(.157"),5mm(.197"),7mm(.276"),9mm(.351")

NOTE: 37 POSITION HAS (4) HOUSING
SCREWS & (4)NUTS

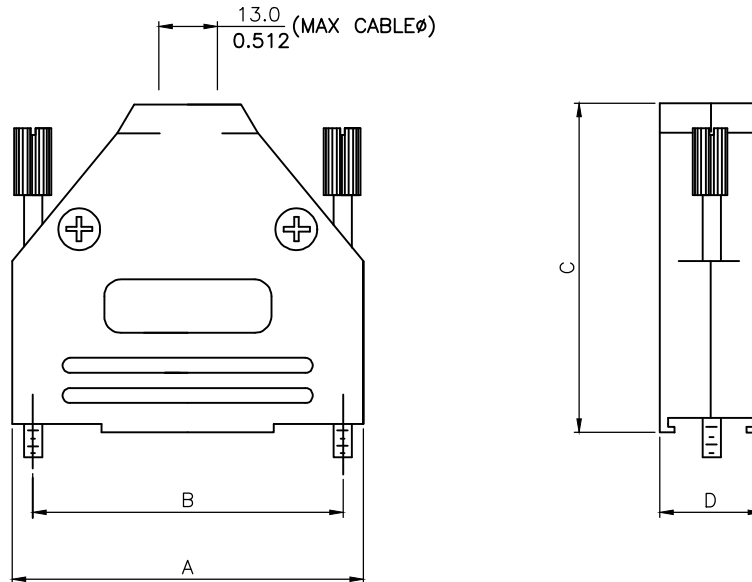

DIMENSIONS(mm/in)								
SIZE	A		B		C		D	
	MM	(±0.50)	MM	(±0.50)	MM	(±0.50)	MM	(±0.50)
	INCH	(±0.02)	INCH	(±0.02)	INCH	(±0.02)	INCH	(±0.02)
9	MM	31.50	MM	24.99	MM	40.50	MM	15.00
	INCH	1.240	INCH	0.984	INCH	1.594	INCH	0.591
15	MM	40.00	MM	33.32	MM	40.50	MM	15.00
	INCH	1.575	INCH	1.312	INCH	1.594	INCH	0.591
25	MM	54.00	MM	47.04	MM	49.50	MM	15.00
	INCH	2.126	INCH	1.852	INCH	1.949	INCH	0.591
37	MM	70.50	MM	63.50	MM	54.50	MM	16.00
	INCH	2.776	INCH	2.500	INCH	2.146	INCH	0.630

ORDERING INFORMATION:

SIZE	P/N - KITTED	PRODUCT CODE
9-WAY	6560-0145-01	MHDTPK-9-K
15-WAY	6560-0145-02	MHDTPK-15-K
25-WAY	6560-0145-03	MHDTPK-25-K
37-WAY	6560-0145-04	MHDTPK-37-K

SIZE	P/N - BULK	PRODUCT CODE
9-WAY	6561-0145-01	MHDTPK-9
15-WAY	6561-0145-02	MHDTPK-15
25-WAY	6561-0145-03	MHDTPK-25
37-WAY	6561-0145-04	MHDTPK-37

PLASTIC: ABS UL 94-HB RATED
PLATING: NICKEL PLATED
JACKSCREWS: STEEL-ZINC PLATED
M3 HOODSCREWS: STEEL-ZINC PLATED
COMPRESSION INSERTS: ABS UL 94-HB RATED
M3 NUTS: STEEL-ZINC PLATED
OPERATING TEMP: -55°C TO+110°C

THESE DRAWINGS AND SPECIFICATIONS ARE THE
PROPERTY OF MH CONNECTORS AND SHALL NOT BE
REPRODUCED, COPIED OR USED AS THE BASIS FOR
THE MANUFACTURE OR SALE OF APPARATUS WITHOUT
WRITTEN PERMISSION.

DRAWN
Johnny
DATE
03-15-22

APPROVED
Victor Lin
DATE
03-15-22

SCALE SHEET OF REV:
1 OF 2 4.0

DRAWING No
MHDTPK SERIES



THIS SERIES FULLY CONFORMS TO THE
EUROPEAN UNION DIRECTIVES 2002/95/EC
AND 2002/96/EC FOR RoHS COMPLIANCY.



**MH CONNECTORS ,
DIVISION OF EDAC**

THIS IS A C.A.D. GENERATED DRAWING
DO NOT MAKE MANUAL REVISIONS TO MASTER.

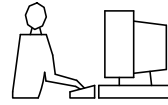

* UNLESS OTHERWISE SPECIFIED TOLERANCES
ON DECIMAL IS:

DRAWING UPDATED	③
Johnny	DEC.04-2020
DRAWING UPDATED	④
Johnny	March.15-2022

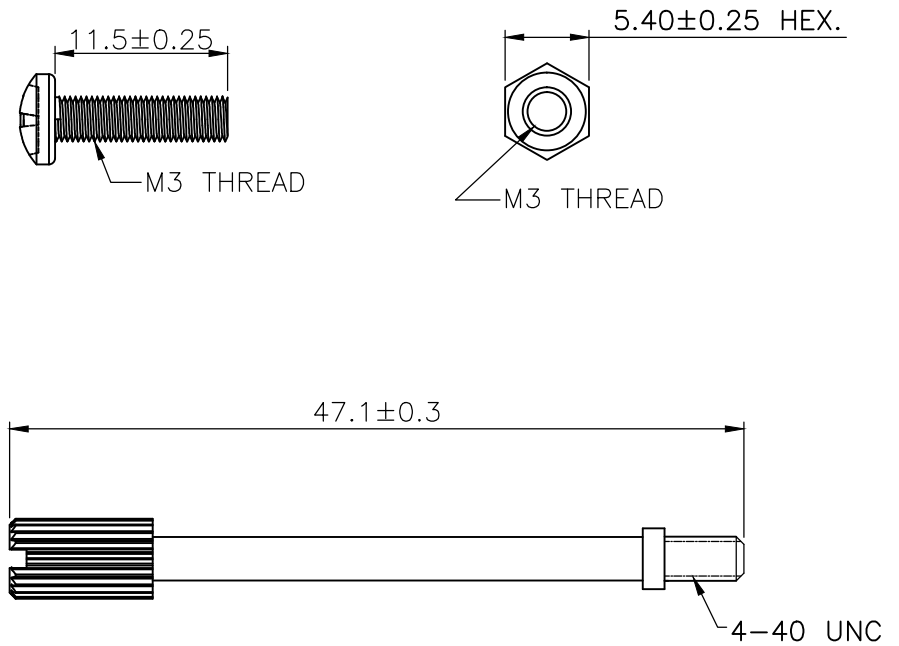
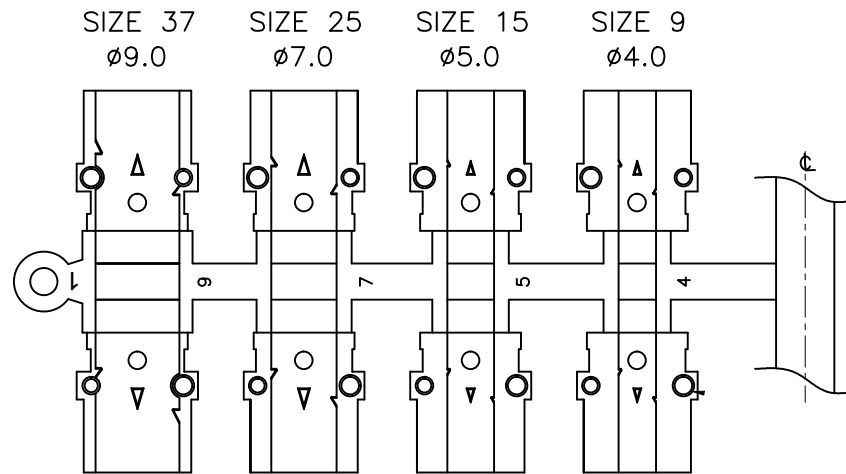

THESE DRAWINGS AND SPECIFICATIONS ARE THE PROPERTY OF MH CONNECTORS AND SHALL NOT BE REPRODUCED, COPIED OR USED AS THE BASIS FOR THE MANUFACTURE OR SALE OF APPARATUS WITHOUT WRITTEN PERMISSION.

DRAWN	DATE
Johnny	03-15-22

APPROVED	DATE
Victor Lin	03-15-22

SCALE	SHEET OF	REV:
	2 OF 2	4.0

DRAWING No	MH DTPK SERIES
------------	----------------



THIS SERIES FULLY CONFORMS TO THE EUROPEAN UNION DIRECTIVES 2002/95/EC AND 2002/96/EC FOR RoHS COMPLIANCY.



**MH CONNECTORS ,
DIVISION OF EDAC**

THIS IS A C.A.D. GENERATED DRAWING
DO NOT MAKE MANUAL REVISIONS TO MASTER.

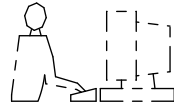

* UNLESS OTHERWISE SPECIFIED TOLERANCES
ON DECIMAL IS: ANGLE X.° ± 3' X.X' ± 1"
UNIT: MM
X. ± 0.30
X.X ± 0.25
X.XX ± 0.20
X.XXX ± 0.15

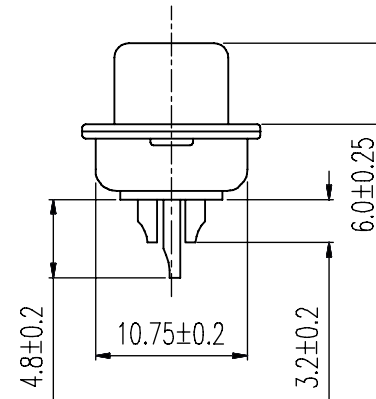
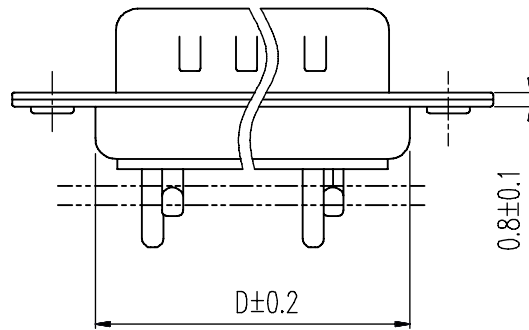
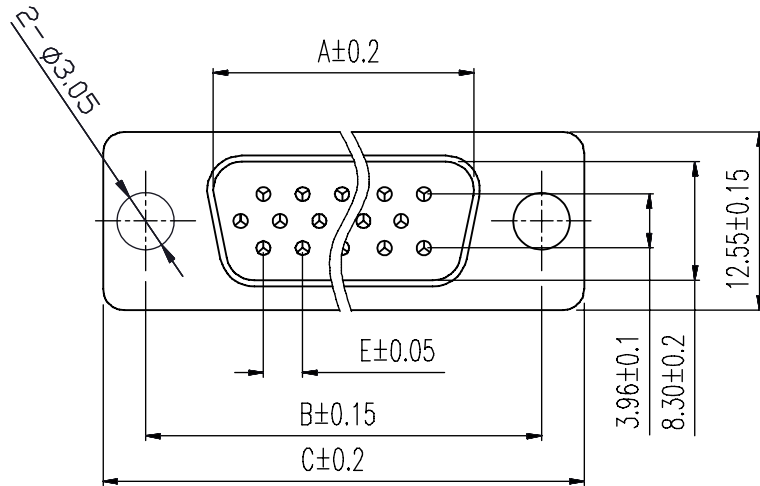

Order Codes:

Plug Connector Stamped & Formed

15-WAY	MHHDS-15-M-N-B-S
26-WAY	MHHDS-26-M-N-B-S
44-WAY	MHHDS-44-M-N-B-S
62-WAY	MHHDS-62-M-N-B-S

POS.	A	B	C	D	E
15	16.90	24.99	30.80	19.10	2.29
26	25.30	33.32	39.10	27.75	2.29
44	39.00	47.04	53.00	41.30	2.29
62	55.40	63.50	69.30	57.40	2.41

Remark:1.MATERIAL:

Plastic:PBT+30% G.F (UL94V-0) BLACK

Spcc shell:Spcc front shell is nickel plated back shell is nickel plated

THESE DRAWINGS AND SPECIFICATIONS ARE THE PROPERTY OF MH CONNECTORS AND SHALL NOT BE REPRODUCED, COPIED OR USED AS THE BASIS FOR THE MANUFACTURE OR SALE OF APPARATUS WITHOUT WRITTEN PERMISSION.

DRAWN
IVEN Ou DATE
08-18-22

APPROVED DATE

SCALE SHEET OF REV:
1 : 1 1 OF 1 3.0

DRAWING No
MHHDS-XX-M-N-B-S



THIS SERIES FULLY CONFORMS TO THE EUROPEAN UNION DIRECTIVES 2002/95/EC AND 2002/96/EC FOR RoHS COMPLIANCY.



MH CONNECTORS,
DIVISION OF EDAC