

Teilenummer part number	Anschluss- querschnitt terminal cross-section	AWG AWG	Merkmal mark	Länge L length L	Gewicht weight	Crimpzange crimp tool	Crimpbacken crimping dies
N 01 060 0007 1 	16 mm ²	6	1 groove	49	15 g	EK 12042 (Klauke) oder / or AHPW 400C (Neko)	TE 0600 062
N 01 060 0004 1 	25 mm ²	4	2 grooves	49	15 g		TE 0600 042
N 01 060 0008 1 	35 mm ²	2	3 grooves	51	20 g		TE 0600 022

General Characteristics	Standard	Value
contacts termination technique		crimp
contacts type		machined contacts
cable type	IEC 60228	class 5 (fine-strand)
stripping length		N 01 060 0007 1 / N 01 060 0004 1: 15 ⁺² ₋₀ N 01 060 0008 1: 17 ⁺² ₋₀
Electrical Characteristics	Standard	Value
rated current T _{amb} = 40 °C		depending on contact insert
current carrying capacity	IEC 60512-5-2	see derating curve
contact resistance	IEC 60512-2-1	≤ 5 mΩ
Climatical Characteristics	Standard	Value
operating temperature	IEC 60068-1	-40 - +125 °C
Mechanical Characteristics	Standard	Value
mechanical operation	IEC 60512-9-1	≥500 mating cycles
mating/unmating force (in new condition)	IEC 60512-16-5	≤70 N
Materials	Standard	Value
contact material		copper alloy
contact plating contact area		Ag (silver)
touch protection material		PA-GF
touch protection flammability	UL 94	V-0
touch protection color		black

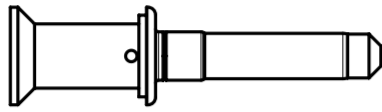
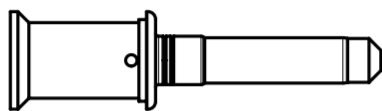
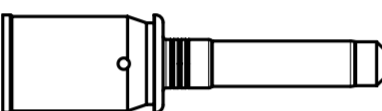
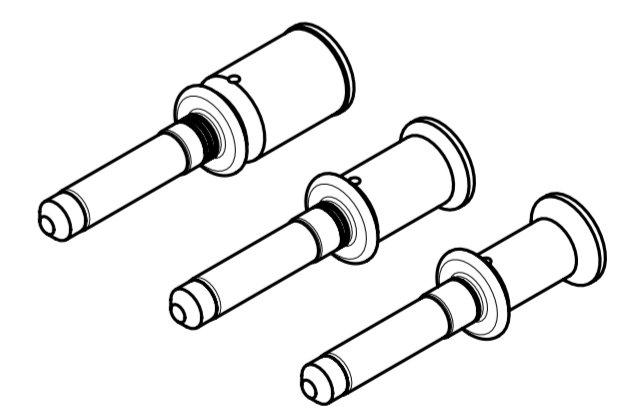
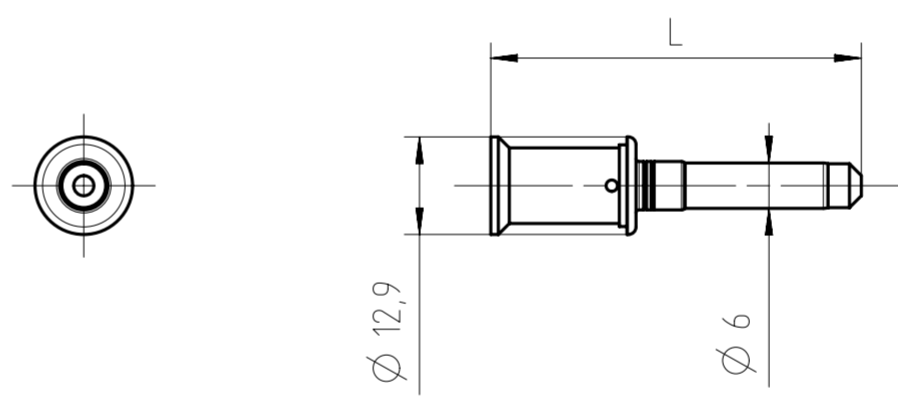

Alle technischen Daten wurden unter Laborbedingungen ermittelt und können im Praxisbetrieb abweichen. Es handelt sich bei den Angaben weder um Beschaffenheits- noch um Haltbarkeitsgarantien. All technical data have been measured in a laboratory environment and can be different during practical usage of the product. Any product information is for descriptive usage only and not legally binding, particularly the information does not constitute or provide any legal guarantees ("Beschaffenheitsgarantie" or "Haltbarkeitsgarantie").

Weitergabe sowie Vervielfältigung dieser Unterlage, Verwertung und Mitteilung ihres Inhalts nicht gestattet, soweit nicht ausdrücklich zugestanden. Zuwiderhandlungen verpflichten zu Schadenersatz. Alle Rechte für den Fall der Patenterteilung oder Gebrauchsmuster-Eintragung vorbehalten.

Copying of this document and giving it to others and the use or communication of the contents thereof, are forbidden without express authority. Offenders are liable to the payment of damages. All rights are reserved in the event of the grant of a patent or the registration of the utility model or design.

Gewicht (errechnet) / Calc. WT.: 14,6 g	Zul. Abw./Tolerances:	Maßstab / Scale: 1:1	A2
Prüfmaß / Testdimension	ISO 2768-mH	CUSTOMER DRAWING	
Teilindex / Partindexnumber:	DIN / ISO 13715	Stiftkontakt 25mm ² pin contacts RADSOK Ø6 mm	
Bagatelle change:	Gez. 21.02.2019 Drawn PWOLFFLE Status Released Gepr. 16.08.2021 Checked MCARLE	M N 01 060 000X 1	
03 202000167 01.06.2021 PWOLF	Amphenol Tuchel Industrial GmbH	Ers. f. / Replacement for:	Blatt / Sheet 1
02 201900101 22.04.2021 PWOLF			1 Bl.
01 201900103 21.02.2019 PWOLF			
Index Änderung / Description	Datum / Date	Name	